

# User's Manual

## TK-850/JH3E+NET

**Date published: Aug 2009**  
**Rev. 1.0**  
**© TESSERA TECHNOLOGY INC. 2009**  
**Printed in Japan**

Windows and Windows XP are registered trademarks or trademarks of Microsoft Corporation in the United States and/or other countries.

- The information is subject to change without notice.
- No part of this document may be copied or reproduced in any form or by any means without prior written consent of TESSERA TECHNOLOGY INC.. TESSERA TECHNOLOGY INC. assumes no responsibility for any errors that may appear in this document.
- TESSERA TECHNOLOGY INC. does not assume any liability for infringement of patents, copyrights or other intellectual property rights of third parties by or arising from the use of TESSERA TECHNOLOGY INC. products listed in this document or any other liability arising from the use of such products. No license, express, implied or otherwise, is granted under any patents, copyrights or other intellectual property rights of TESSERA TECHNOLOGY INC. or others.
- Descriptions of circuits, software and other related information in this document are provided for illustrative purposes in semiconductor product operation and application examples. The incorporation of these circuits, software and information in the design of a customer's equipment shall be done under the full responsibility of the customer. TESSERA TECHNOLOGY INC. assumes no responsibility for any losses incurred by customers or third parties arising from the use of these circuits, software and information.

#### CAUTION

- Do not give any physical damage to this equipment such as dropping
- Do not superimpose voltage to this equipment.
- Do not use this equipment with the temperature below 0°C or over 40°C.
- Make sure the USB cables are properly connected.
- Do not bend or stretch the USB cables.
- Keep this equipment away from water.
- Take extra care to electric shock.
- This equipment should be handled like a CMOS semiconductor device. The user must take all precautions to avoid build-up of static electricity while working with this equipment.
- All test and measurement tool including the workbench must be grounded.
- The user/operator must be grounded using the wrist strap.
- The connectors and/or device pins should not be touched with bare hands.

## Contents

|                                                  |    |
|--------------------------------------------------|----|
| CHAPTER 1 PREPARATION.....                       | 7  |
| 1.1 Development Tools / Software.....            | 8  |
| 1.2 Installation of Development Tools .....      | 9  |
| 1.2.1 Installation Package .....                 | 9  |
| 1.2.2 Installation of Development Tools.....     | 9  |
| 1.3 Sample Programs.....                         | 14 |
| 1.3.1 Preparation of Sample Programs.....        | 14 |
| 1.3.2 Overview of Sample Programs .....          | 17 |
| 1.4 Installation of USB Driver .....             | 18 |
| 1.4.1 Installation on Windows XP .....           | 19 |
| 1.4.2 Installation on Windows 2000 .....         | 22 |
| 1.4.3 Completion of USB Driver Installation..... | 25 |
| CHAPTER 2 EXPERIENCES.....                       | 26 |
| 2.1 Start PM+ .....                              | 28 |
| 2.2 What is PM+ .....                            | 29 |
| 2.3 Load Workspace (project) .....               | 31 |
| 2.4 Set Options.....                             | 33 |
| 2.4.1 “General” Tab.....                         | 33 |
| 2.4.2 “Extend” Tab.....                          | 34 |
| 2.4.3 “Preprocessor” Tab .....                   | 34 |
| 2.5 Create Load Module Files .....               | 36 |
| 2.6 Check Debugger Settings.....                 | 38 |
| 2.7 Check Board Settings.....                    | 40 |
| 2.8 Start Debugger (ID850QB).....                | 41 |
| 2.9 Run Programs.....                            | 44 |
| 2.10 Stop Programs .....                         | 46 |
| 2.11 Close Debugger (ID850QB) .....              | 47 |
| 2.12 Quit PM+.....                               | 48 |
| CHAPTER 3 HARDWARE SPECIFICATIONS.....           | 49 |
| 3.1 Layout of hardware functions.....            | 50 |
| 3.2 Layout of solder-short pad .....             | 50 |
| 3.3 Hardware Functions.....                      | 51 |
| 3.3.1 SW1.....                                   | 51 |
| 3.3.2 SW2.....                                   | 52 |
| 3.3.3 SW3 (INTP17) .....                         | 52 |
| 3.3.4 SW4 (INTP18) .....                         | 52 |
| 3.3.5 LED1 (POWER) .....                         | 52 |
| 3.3.6 LED2, LED3 .....                           | 52 |
| 3.3.7 U3(7seg LED) .....                         | 53 |

|                                                                                |    |
|--------------------------------------------------------------------------------|----|
| 3.3.8 JP1 .....                                                                | 53 |
| 3.3.9 CN4.....                                                                 | 53 |
| 3.3.10 J1 .....                                                                | 53 |
| 3.3.11 NWIRE1 Connector .....                                                  | 54 |
| 3.3.12 FP1 .....                                                               | 54 |
| 3.3.13 USB1 .....                                                              | 54 |
| 3.3.14 USB2 .....                                                              | 54 |
| 3.3.15 CAN1 .....                                                              | 54 |
| 3.3.16 TR1.....                                                                | 54 |
| 3.4 solder-short pad label.....                                                | 55 |
| CHAPTER 4 TROUBLESHOOTING.....                                                 | 57 |
| 4.1 If you cannot find USB driver when you connect PC to the kit.....          | 57 |
| 4.2 Error when you start the debugger .....                                    | 57 |
| 4.2.1 "Can not communicate with Emulator..." (F0100 or A0109) .....            | 57 |
| 4.2.2 "Incorrect ID Code." (Ff603) .....                                       | 58 |
| 4.3 Monitor memory cannot be accessed. (F0c72) .....                           | 58 |
| CHAPTER 5 OTHER INFORMATION.....                                               | 59 |
| 5.1 Create a new workspace .....                                               | 60 |
| 5.2 Register additional source file .....                                      | 68 |
| 5.3 Debugger tips .....                                                        | 70 |
| 5.3.1 Change display of buttons .....                                          | 70 |
| 5.3.2 Display source list and function list .....                              | 70 |
| 5.3.3 Set/delete breakpoints.....                                              | 71 |
| 5.3.4 Display global variables.....                                            | 72 |
| 5.3.5 Display global variables (internal RAM) while programs are running ..... | 73 |
| 5.3.6 Display local variables .....                                            | 74 |
| 5.3.7 Display memory and SFR contents .....                                    | 74 |
| 5.4 WriteEZ5.....                                                              | 75 |
| 5.5 Parts list, Circuit diagram.....                                           | 80 |

# Introduction

TK-850/JH3E+NET is the evaluation kit for development using "V850ES/JH3-E", NEC Electronics 32bit all flash microcontroller.

The user only needs to install the development tools and USB driver, and connect the host machine with the target board to start the code development, build, monitoring the output, and debugging code.

(This demonstration kit uses the on-chip debug feature from the microcontroller itself, without emulator connection)

## Configuration for Debugging

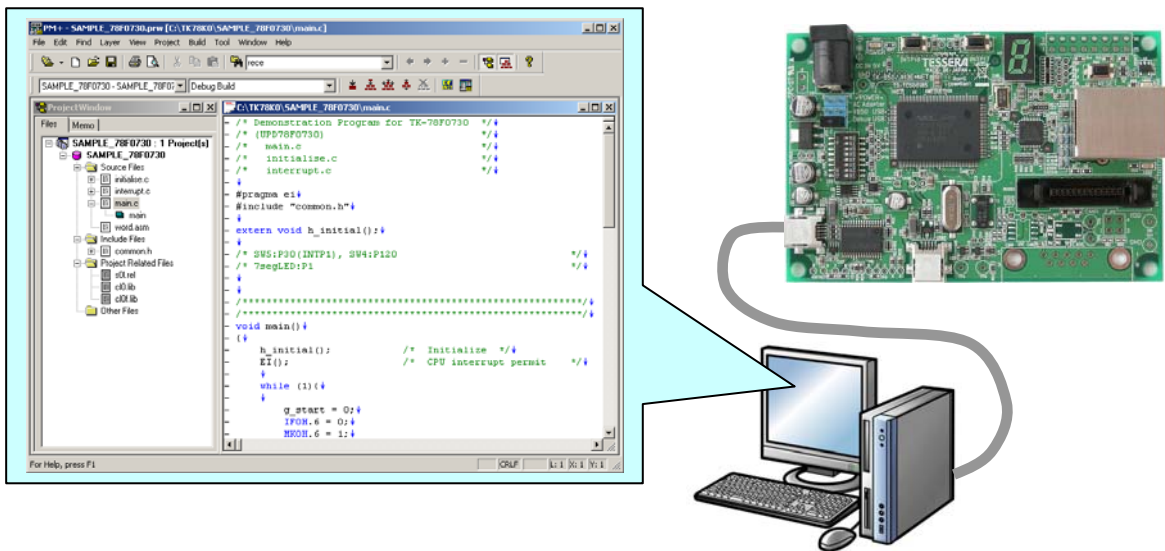

- Overview** This manual consists of the following contents.
- Read chapter 1 and 2 first for installing the development tools and using the sample programs.
  - Read chapter 3-5 for customizing the sample programs and the hardware.
- Chapter 1: Preparations**  
Install the development tools
- Chapter 2: Experiences**  
Experience the basic operations of integrated development environment (PM+) and integrated debugger (ID850QB) with using sample programs.
- Chapter 3: Hardware Specifications**  
Explain the hardware of TK-850/JH3E+NET
- Chapter 4: Troubleshooting**  
Describe how to solve troubles you may face, such as errors when starting the integrated debugger (ID850QB)
- Chapter 5: Other Information**  
Introduce other information, such as how to create a new workspace (project) on integrated development environment (PM+), how to register additional source file, and some useful tips of the integrated debugger. The circuit diagrams of demonstration kit are included in this chapter.
- Reader** This manual is intended for development engineers who wish to become familiar with the development tools for the V850.
- It is assumed that the readers have been familiar with basics of microcontrollers, C and Assembler languages, and the Windows™ operating system.
- Purpose** This manual is intended to give users an understanding of the features, hardware configurations, development tools for the V850.

# CHAPTER 1 Preparation

This chapter describes following topics:

- Overview and installation of development tools
- Installation of development tools
- Overview and preparation of sample programs

Users can experience the development flow such as coding, build, debugging, and test, by using the development tools bundled with TK-850/JH3E+NET.

## 1.1 Development Tools / Software

- **Integrated Development Environment (IDE) PM+ V6.31**

The IDE works on Windows operation system.

Users can develop a system efficiently by using the editor with idea processor function, compiler, and debugger.
- **C Compiler CA850 W3.30 (code size limited version)**

C compiler for the V850 microcontrollers. The object code size is limited to 128 Kbyte.

This compiles C code for V850 and ANSI-C code program into assembler code.

This produces object code and linker.
- **V850 Integrated Debugger ID850QB V3.60**

This is the tool for debugging the object program generated by C compiler and assembler. The debugger enables to do C source level debugging. With the debugger, you can debug the code easily and efficiently by referring and changing variables, using step-in debugging function, and so on.
- **Device file DF703786 V1.00**

A device file contains device specific information. So, users need a device file to use the development tools.
- **Built-in Flash Memory Writing Program WriteEZ5**

This is the Windows software to write programs on built-in flash memory.

By connecting TK-850/JH3E+NET and PC with bundled USB cable, you can write/delete programs on the built-in flash memory.
- **Sample program**

This is the sample program to run the Web server and to send/receive email.

## 1.2 Installation of Development Tools

### 1.2.1 Installation Package

The attached CD-ROM includes the development tools and documentations. Users can use the installer to install those development tools and documentations.

### 1.2.2 Installation of Development Tools

- ① Please insert the CD-ROM in the drive. The installer will show up automatically. If it does not start automatically, please initiate it by double clicking the SETUP.EXE.

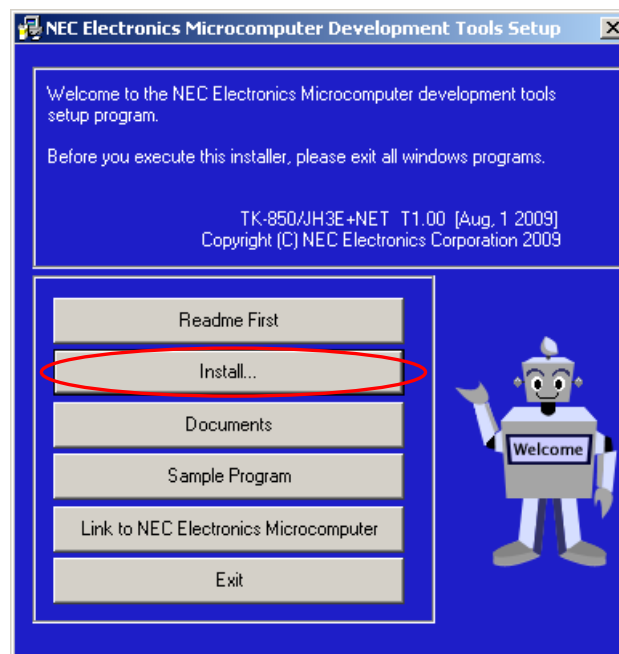

<1> Readme First

The contents of the CD-ROM, and some notes are available.

Please read it at first.

<2> Install...

Click "Install" to start installation of development tools.

For details, please refer to the next section.

<3> Documents

Manuals of development tools and the evaluation kit are available in PDF files.

When this button is clicked, the WWW browser will start. Adobe® Acrobat® Reader is available in the CD-ROM.

<4> Sample Program

Click this button to start the WWW browser for the sample program and the tutorial.

<5> Link to NEC Electronics Microcontrollers

Click this button to start the WWW browser display the link to the NEC Electronics Microcontroller web site ([http://www.necel.com/micro/index\\_e.html](http://www.necel.com/micro/index_e.html))

The NEC Electronics Microcontroller web page provides with the latest product/tool information and FAQs.

<6> Exit

Terminate the setup.

② Click the "Install"

③ "Tool Installer" dialog box is opened.

Select products that you need to install.

(as default, all the products that you need to use the TK-850/JH3E+NET are selected.)

"Explain" area displays an explanation of the selected product.

To change the installation destination, click **Browse...** .

When all the settings are completed, click **Install...** .

\* In this document, it is assumed that users install the programs under "NEC Electronics Tools" directory (default installation directory). Users can find the tools by selecting "Start Menu" -> "Programs" -> "NEC Electronics Tools".

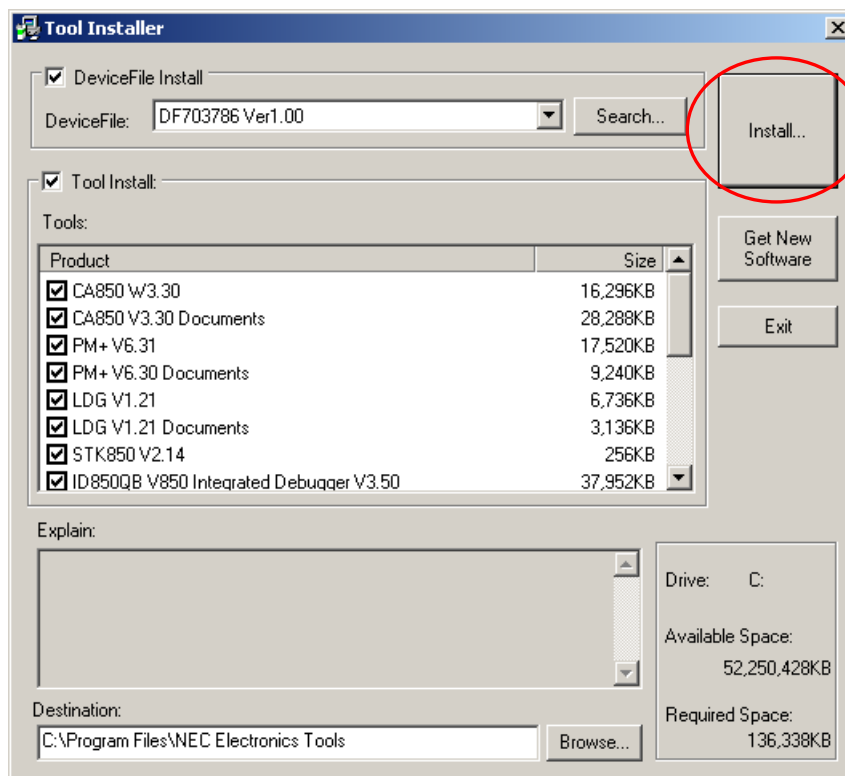

④ Click **OK** when "Install" confirmation dialog box is opened.

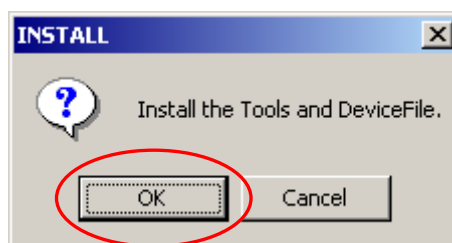

- ⑤ Read "software license agreement" and click  for continuing the installation.  
To stop the installation, click .

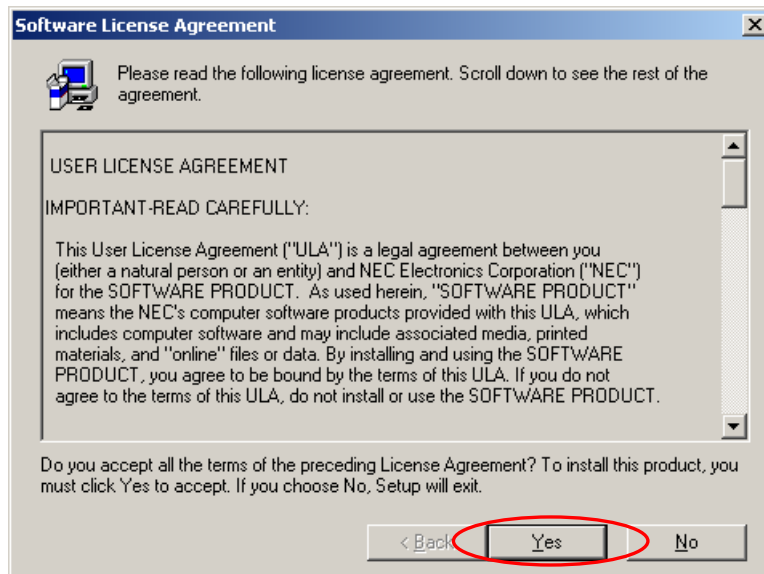

- ⑥ Enter the product ID, and click  .  
\* The product ID is available on the other sheet.

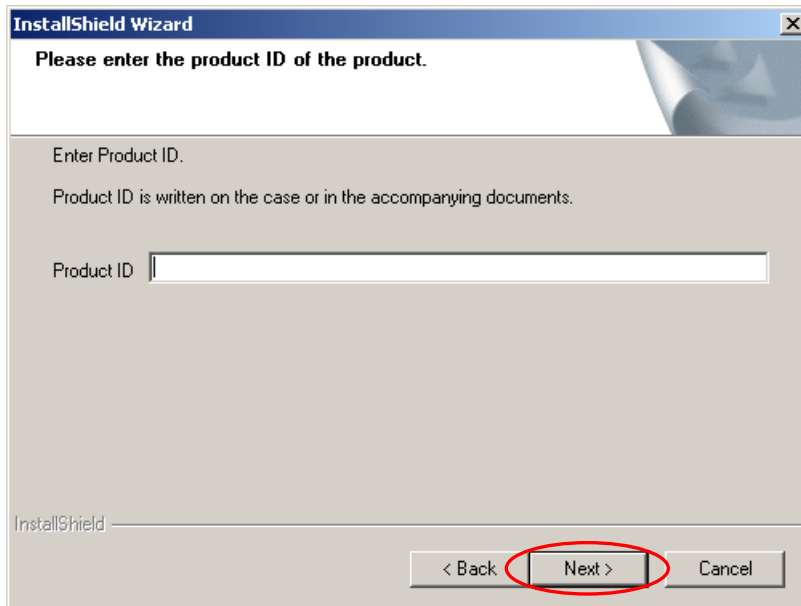

- ⑦ It starts copying the files.

- ⑧ Check the item specified below is selected when "Kind of File" dialog displays.  
Click "Next".

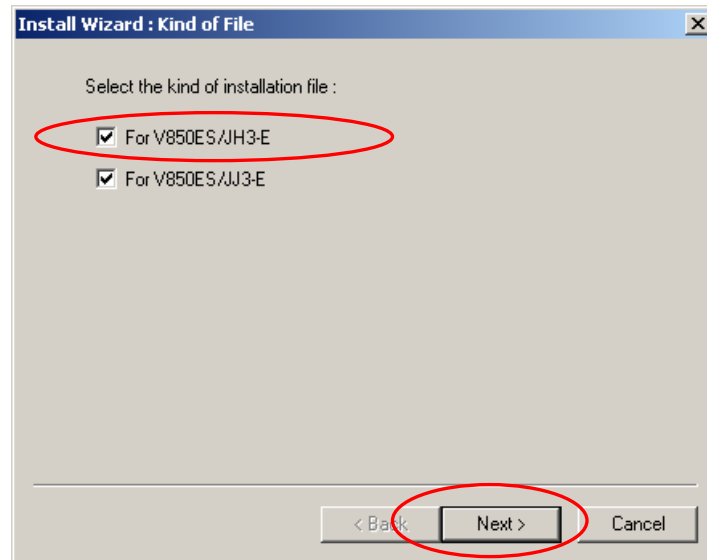

- ⑨ When the installation is completed, the following dialog opens.  
Click **OK**.

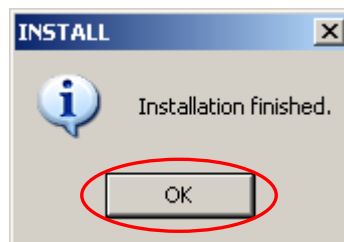

**Notes on the installation authority**

To install this tool in Windows 2000 or XP, the authority of an administrator is necessary. Therefore, please login as an administrator.

**Notes on the install-directory**

Please do not use 2-byte characters, such as umlaut in the directory name, where the product is to be installed.

**Note on the version of Windows**

If the language of the Windows is not English, a file transfer error during installation might be observed. In this case, please abort the installation in the language, and re-install it in an English version of Windows.

The identical problem may be observed, if a language other than English is specified as the system language in the "Regional Settings Properties" tab.

**Limitation**

Assembler RA850 and C compiler CA850 limit the object size to 128Kbyte.

## 1.3 Sample Programs

This section explains the overview and preparation of sample programs.

### 1.3.1 Preparation of Sample Programs

- ① Insert the CD-ROM disk in the CD-ROM drive of your PC. The [NEC Electronics Microprocessor Development Tools Setup] screen automatically appears.(if this screen does not appear automatically, start setup.exe from Explorer. etc.)

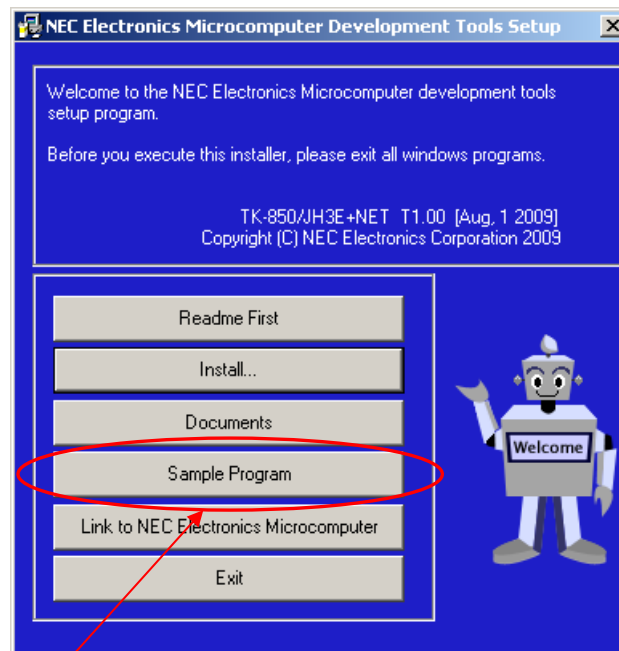

- ② Press the **Sample Program** button to start the WWW browser.

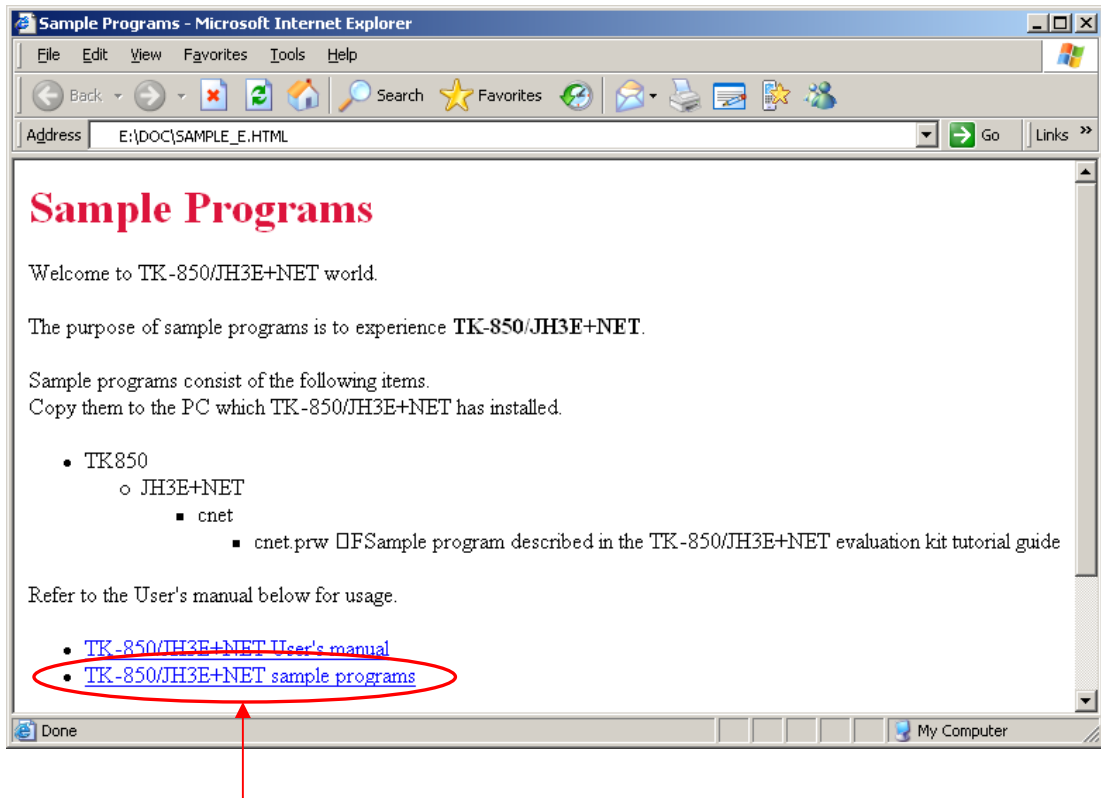

③ Click the “TK-850/JH3E+NET Sample Programs” link , the following download confirmation window appears.

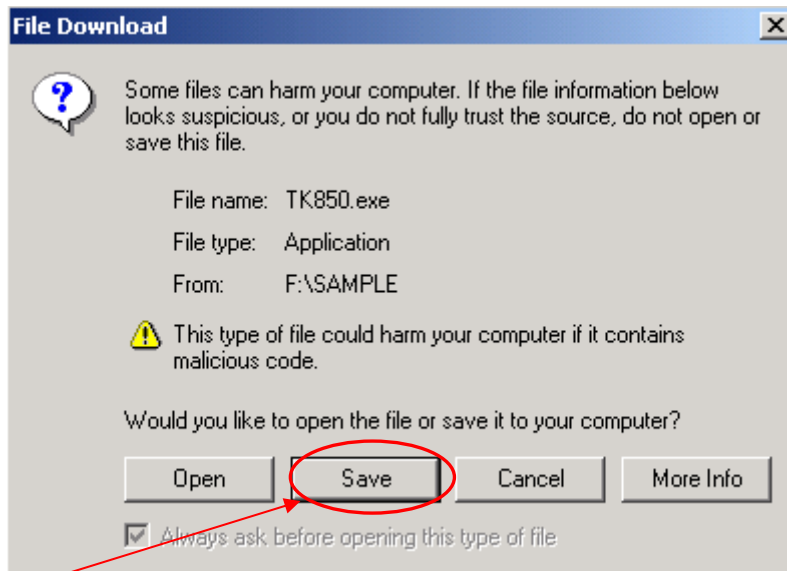

④ Click the **Save** button.

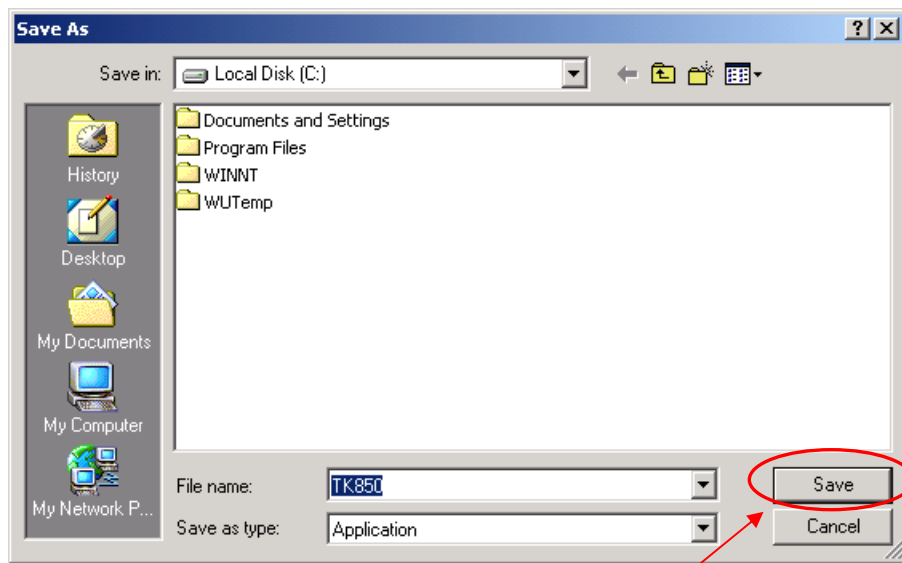

⑤ After specifying the download destination folder, click the **Save** button.

⑥ The self-extraction sample program (TK850.exe) is copied to the specified folder.  
The folder that the "TK850" folder is made when this file is executed, and the sample program is stored under the "TK850" folder.

### 1.3.2 Overview of Sample Programs

The sample programs consist of following folders.

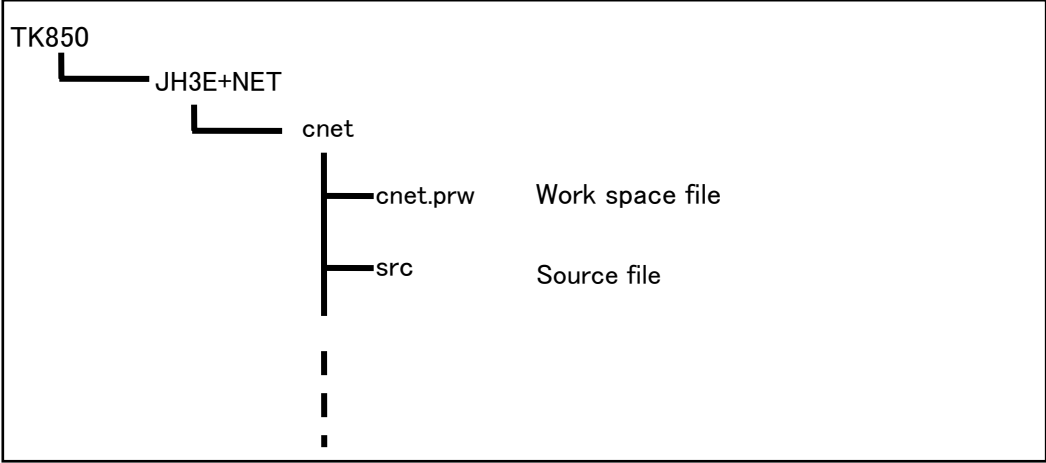

## 1.4 Installation of USB Driver

"NEC Electronics Starter Kit Virtual UART" USB driver must be installed on PC before you start using the TK-850/JH3E+NET.

Please, follow the instruction below to install the driver.

"Starter Kit USB Driver" must be installed on the PC. If not, please refer to "1.2 Installation of Development Tools" to install the driver first.

**CAUTION:**

**Do not use a USB hub for connecting TK-850**

First, connect the TK-850 to PC with USB.

Depending on the version of Windows OS, the installation will be differed. Please check your Windows version, and follow the instructions

- Windows XP → "1.4.1 Installation on Windows XP"
- Windows 2000 → "1.4.2 Installation on Windows 2000"

After the installation, go to "1.4.3 Completion of USB Driver Installation"

## 1.4.1 Installation on Windows XP

1. Once the TK-850/JH3E+NET is connected with USB, the "Found New Hardware Wizard" will be started.

Select "No, not this time" and click **Next >** .

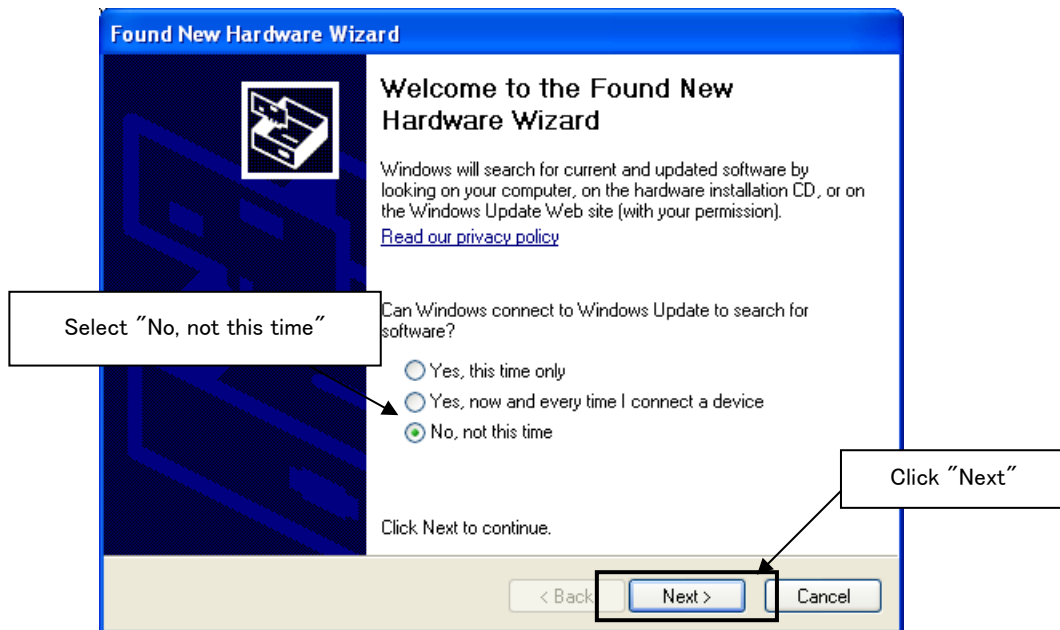

2. Select "Install from a list or specific location" and click **Next >** .

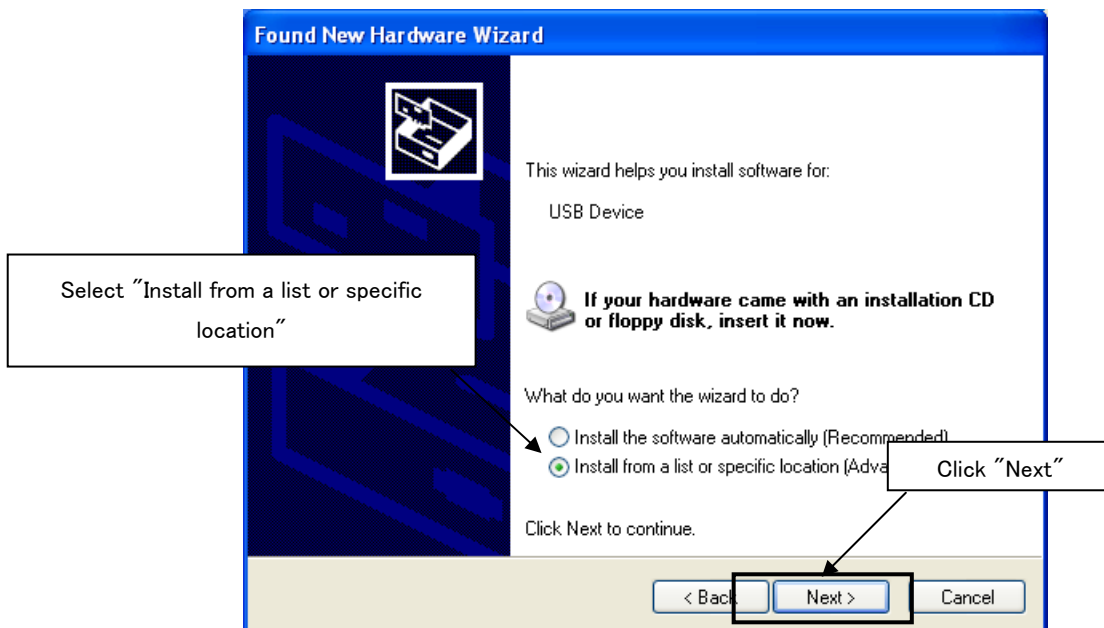

3. Select "Search for the best driver in these locations.", check "Include this location in the search:", and then click "Browse..." to select the driver directory path. The path should be "C:\Program Files\NEC Electronics Tools\TK-driver" as default installation. If the installation directory is not default, then select "TK-driver" under the installation directory.  
Click **Next >** .

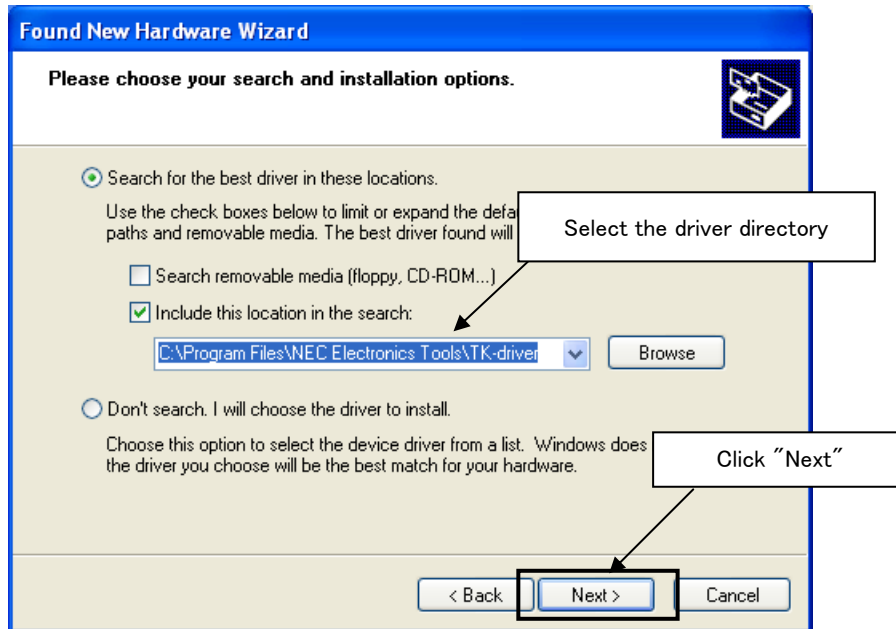

4. If the following dialog is opened, click **Continue Anyway** .

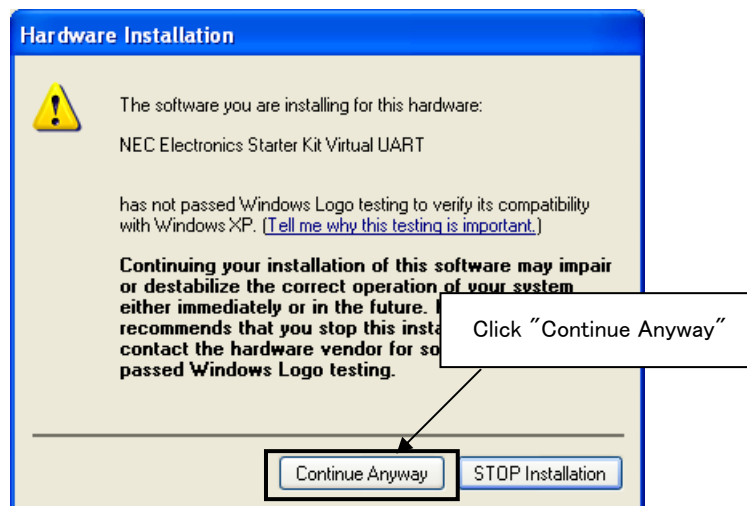

5. The installation of "NEC Electronics Starter Kit Virtual UART" driver is completed. Click **Finish** .

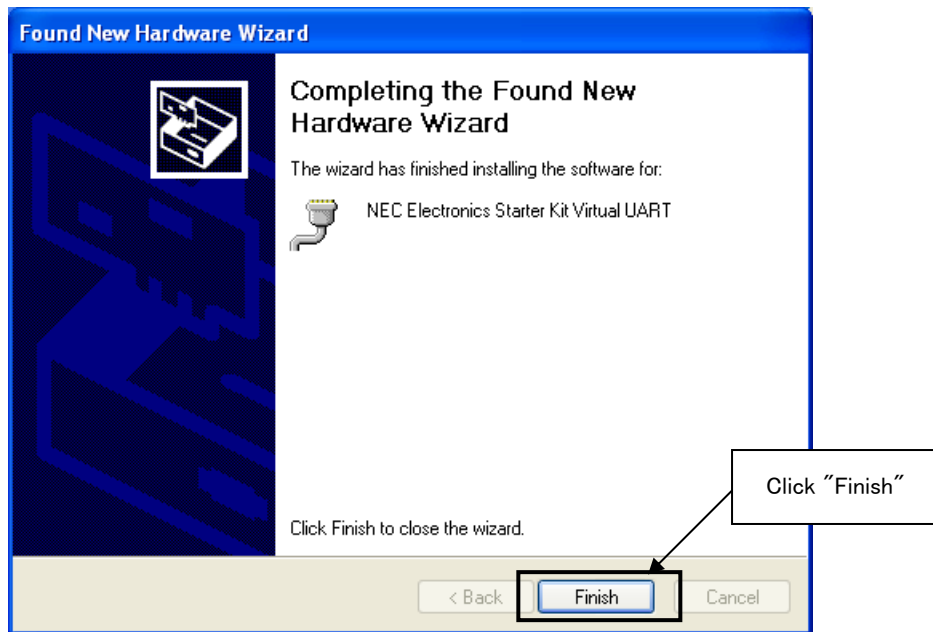

6. Go to "[1.4.3 Completion of USB Driver Installation](#)".

## 1.4.2 Installation on Windows 2000

1. Once the TK-850/JH3E+NET is connected with USB, the "Found New Hardware Wizard" will be started.

Select "No, not this time" and click **Next >** .



2. Select "Search for a suitable driver for my device".

Click **Next >** .

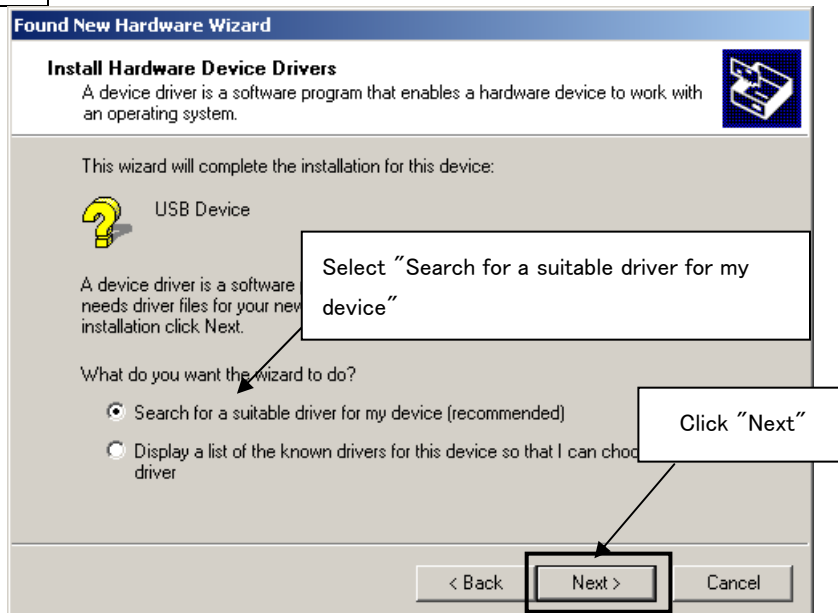

3. Select "Specify a location".  
Click **Next >** .

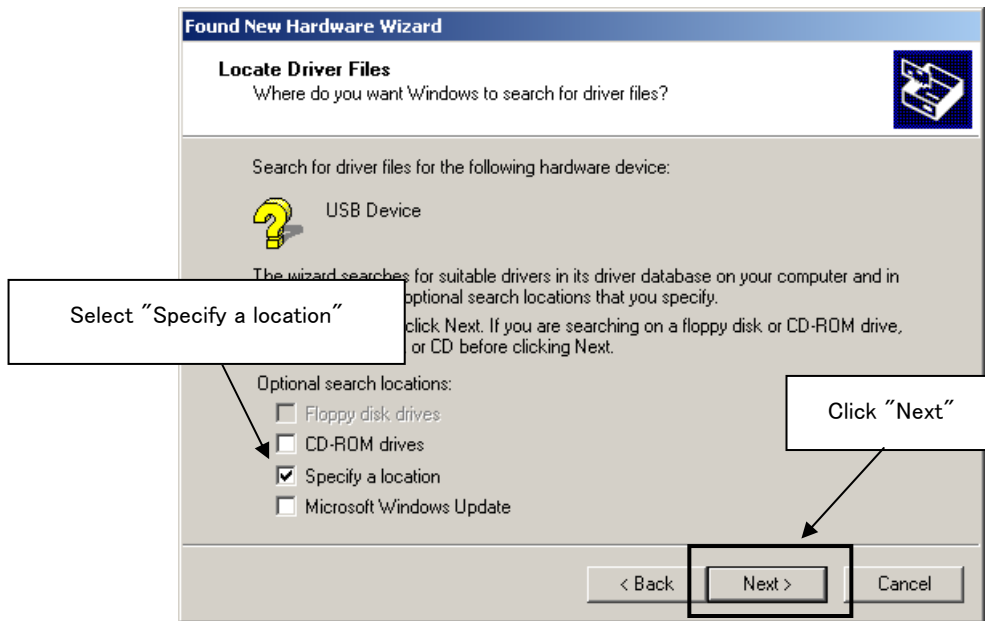

4. Select the driver directory path. The path should be "C:\Program Files\NEC Electronics Tools\TK-driver" as default installation.  
If the installation directory is not default, then select "TK-driver" under the installation directory.  
Click **OK** .

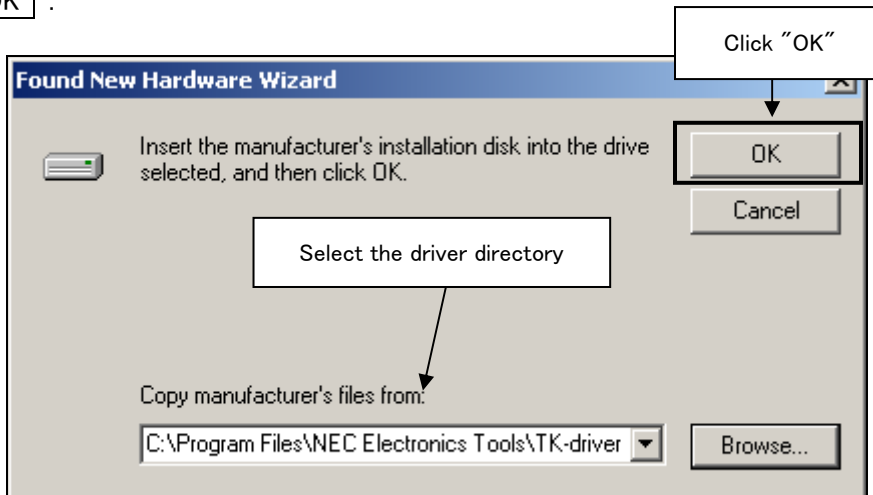

5. Click **Next >** .

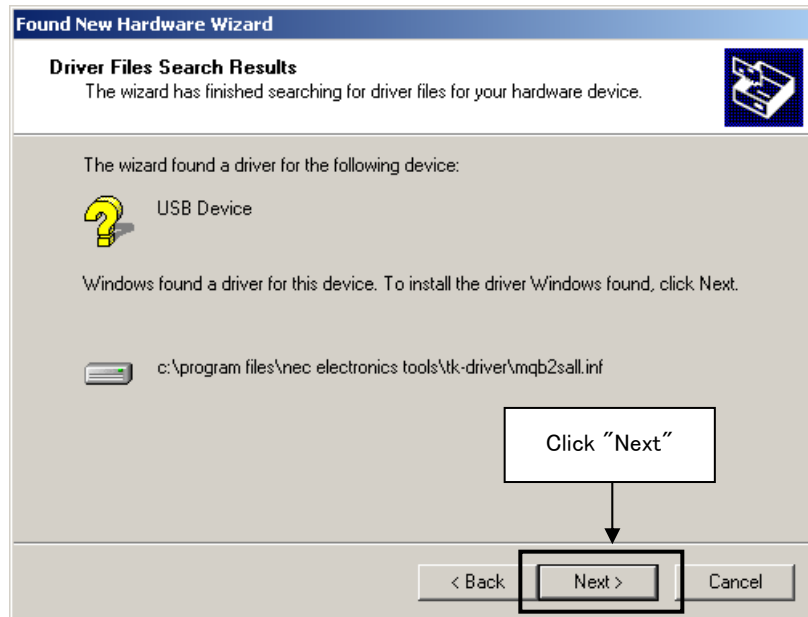

6. The installation of "NEC Electronics Starter Kit Virtual UART" driver is completed. Click **Finish** .



7. Go to "[1.4.3 Completion of USB Driver Installation](#)".

### 1.4.3 Completion of USB Driver Installation

Confirm the USB driver is installed on PC.

Start "Device Manager", and find "NEC Electronics Starter Kit Virtual UART" (without "?" mark) under the "Ports (COM & LPT)".

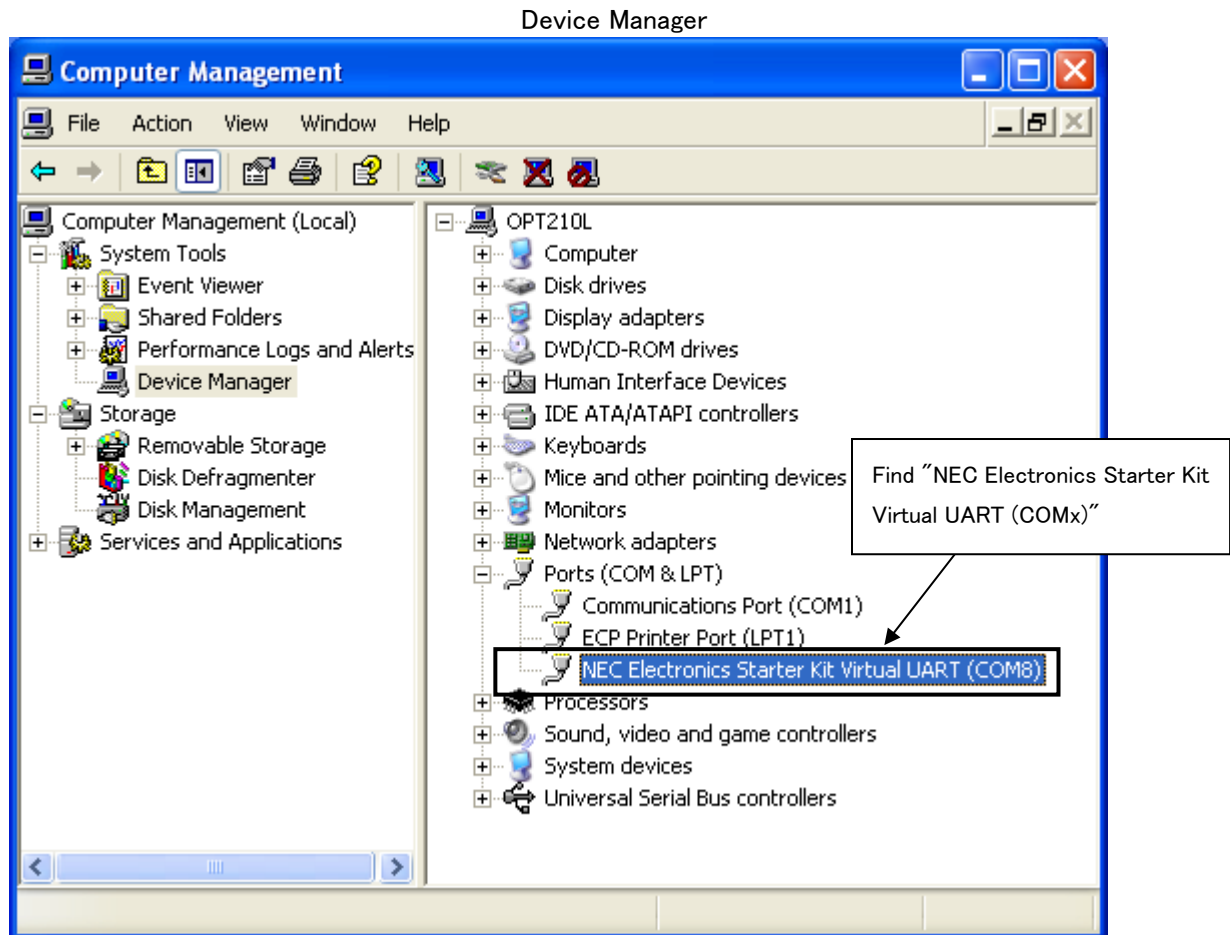

The screen above shows that the COM port number is "COM8". If ID850QB is not in use, you can use this port number for connecting TK-850/JH3E+NET.

When you change the USB port connection, the COM port number will be changed as well.

**Select this COM port number when you use WriteEZ5.**

#### CAUTION

- Do not do "Hardware Modification Scan" when you communicate with the target device.

## CHAPTER 2 Experiences

In this chapter, you will experience how to use the development tools with using the sample programs.

The development tools are :

- Integrated Development Environment (IDE), PM+
- Integrated Debugger, ID850QB

You will use the programs that you prepared in "1.3 Sample Programs", as the sample programs for TK-850/JH3E+NET

You will be able to understand how to use the development tools and the concept of project files which you need for producing application programs.

The overall steps are as follows:

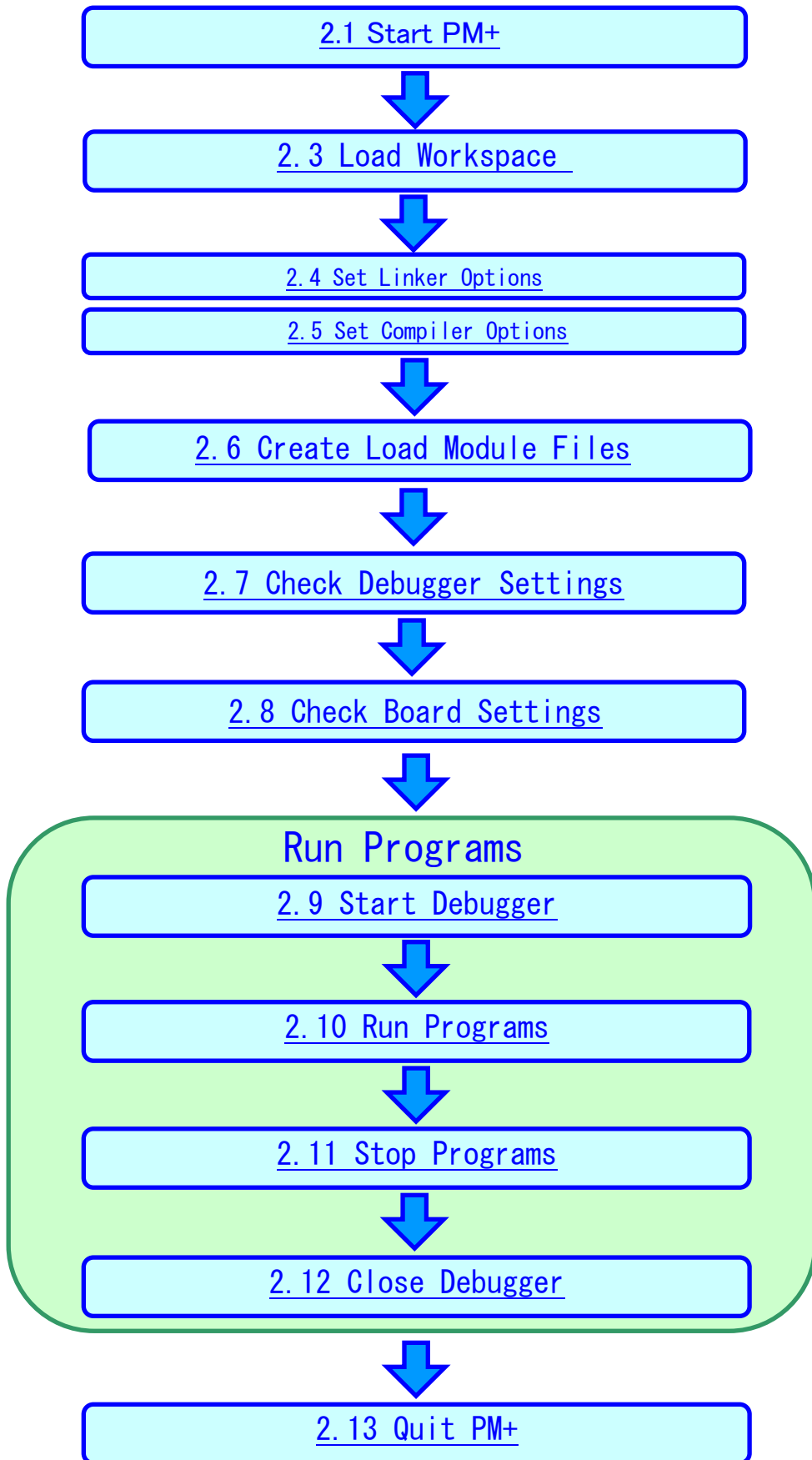

## 2.1 Start PM+

Let's start using the development tools.

First, start the PM+

Select "Windows Start Menu" -> "Program" -> "NEC Electronics Tools" -> "PM+ V6.31".

PM+ starts up

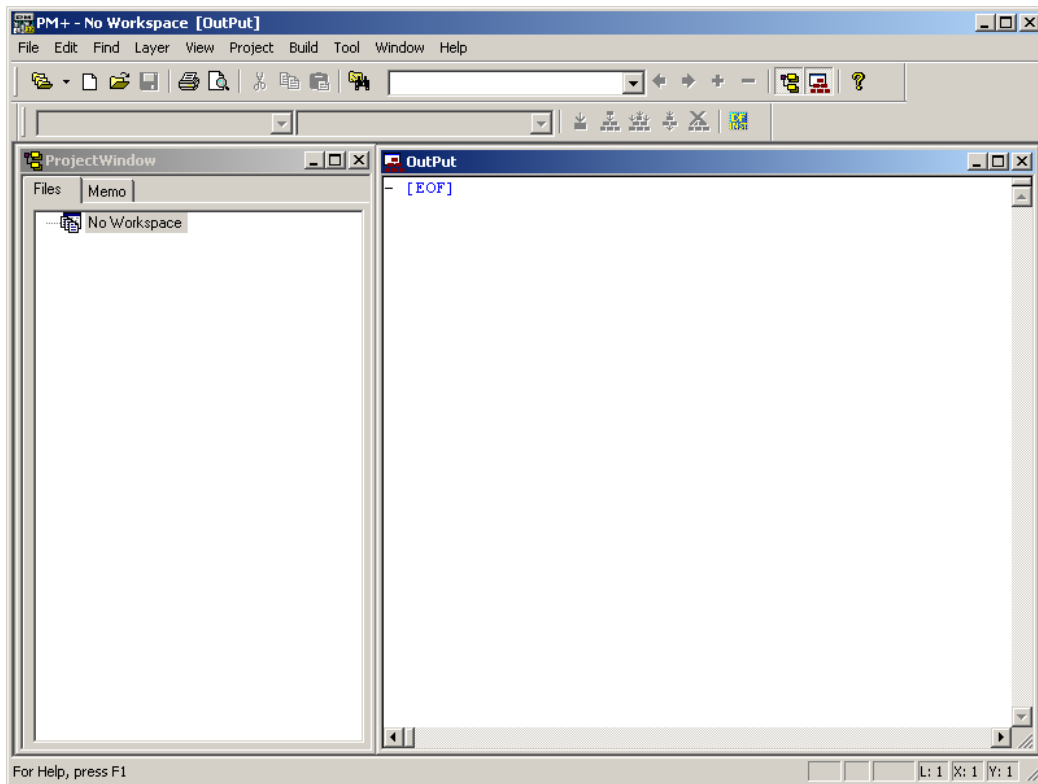

## 2.2 What is PM+

In PM+, application programs and environment setting are handled as a single project, and series of actions such as program creation using the editor, source management, build, and debugging are managed.

Also, one or more project files is managed together as a workspace.

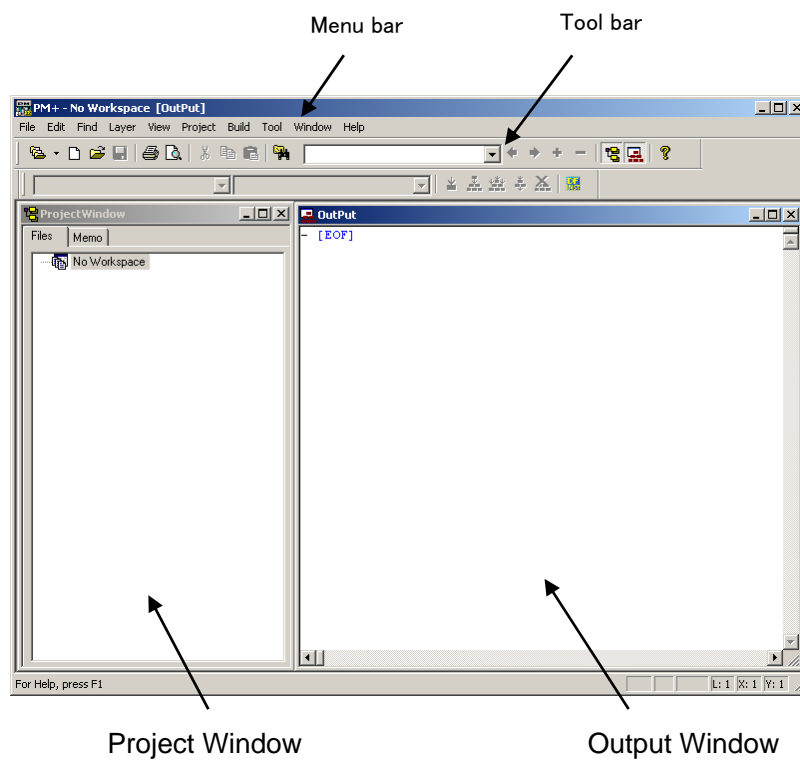

- Project window A window in which project names, source files, and include file are displayed using a tree structure.
- Output window A window in which the build execution status is displayed.

➡ For details regarding menu bars and tool bars, refer to "Help" menu in PM+.  
"Help" on menu bar , then "PM+ Help"

### **What is a project?**

A project is the unit that is managed by PM+. A project refers to an application system and environment development based on PM+.

PM+ saves project information in a "project file".

### **What is a project file?**

A project file contains project information that includes the source files, device name, tool options for compiling, editor, and debugger information.

The file name format is "xxxxx.prj".

Project files are created in the directory you specifies when you create a new workspace.

### **What is a project group?**

A project group is a group comprised of a number of projects in an application system.

The target device of each project must be the same within a project group.

### **What is a workspace?**

A workspace is the unit used to manage all the projects and project group required for one application system.

A workspace file contains one or more project files.

The file name format is "xxxxx.prw".

## 2.3 Load Workspace (project)

In this section, you will use the workspace that you created in "1.3 Sample Programs"  
For creating a new workspace, refer to "Chapter 5 Other Information".

The workspace has information about the build environment for the sample programs.

Select "File" on menu bar and "Open Workspace...".

Then, select "cnet.prw" under the directory "C:\TK850\JH3E+NET\cnet".

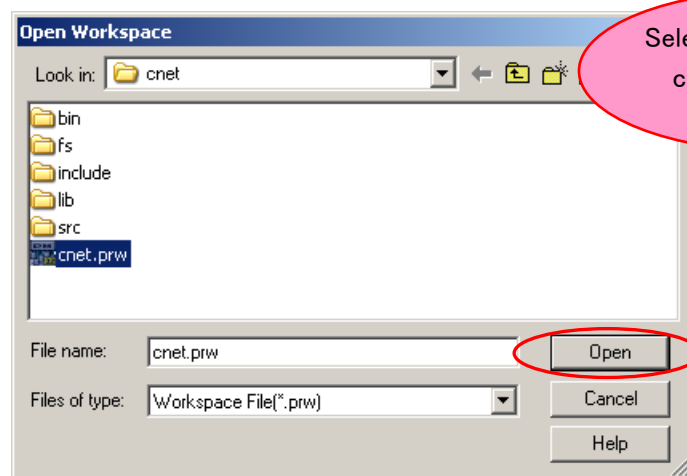
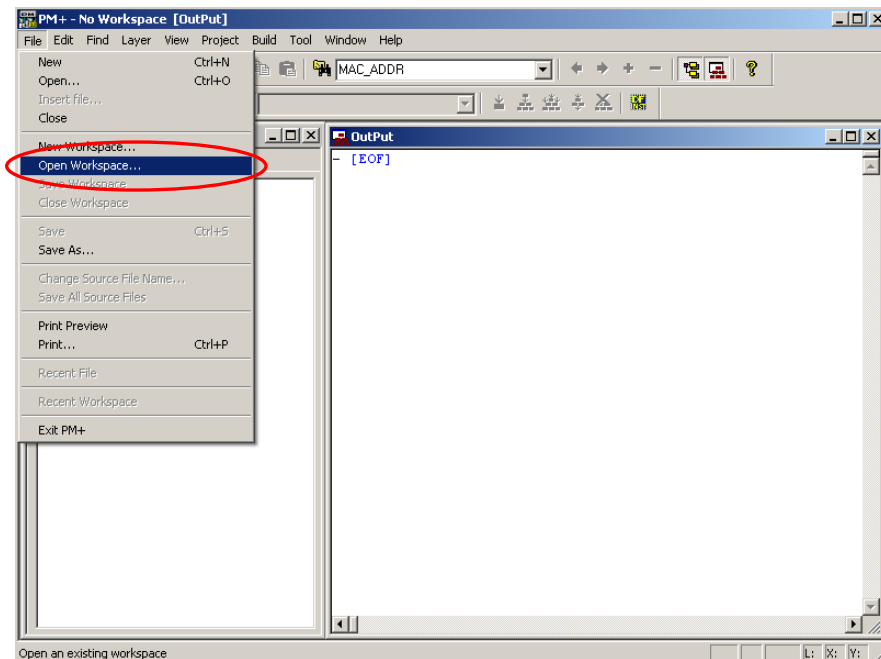

Select "cnet.prw", then click  .

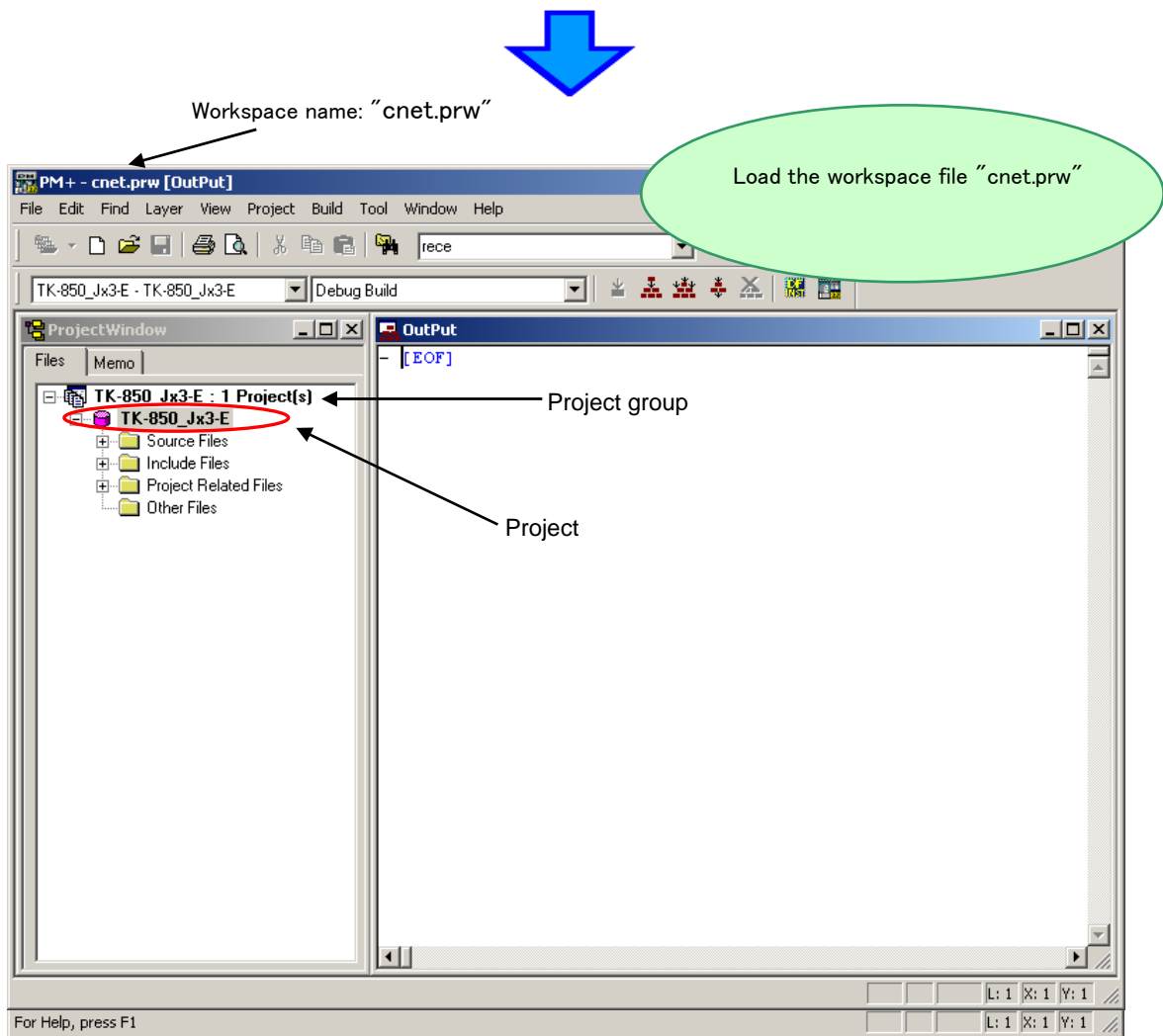

The workspace file "cnet.prw" contains one project called "cnet.prw". You will use this project "TK-850\_Jx3-E".

**CAUTION:**

Please ignore when you get a prompt saying "files could not be found". This may occurred when the installation directory is not a default.

## 2.4 Set Options

The compiler options have been set by project file. However, because some compiler options are useful, following two settings are covered specifically in this section.

- MAC address setting
- Enable C++ comments
- On-chip debug (Disable/Enable, security ID)

Select "Tools" on menu bar, then "Compiler Common options".

### 2.4.1 "General" Tab

Select "Tool" on menu bar in PM+, then "Compiler Options...".

Select "General" tab, and specify the MAC address in "Define macro" field as described below.

You can find the MAC address on the back side of substrate.

#### To Specify MAC Address (physical address):

Add ";SPEC\_MACADDR=0x00,0x11,0x22,0x33,0x44,0x55;" in "Define macro" field if the MAC address is "MAC:00-11-22-33-44-55" on the back of substrate.

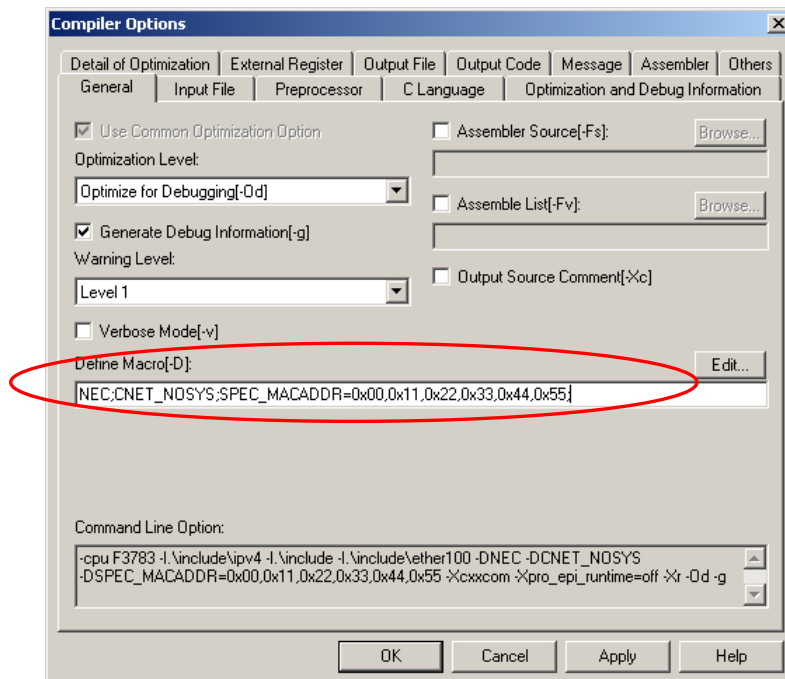

#### Caution

MAC address is not specified in the sample program as default. This causes a compiling error when you compile it. Therefore, set the MAC address before building it.

## 2.4.2 "Extend" Tab

Select "Device" tab on "Compiler Common Options" window, and check following settings.

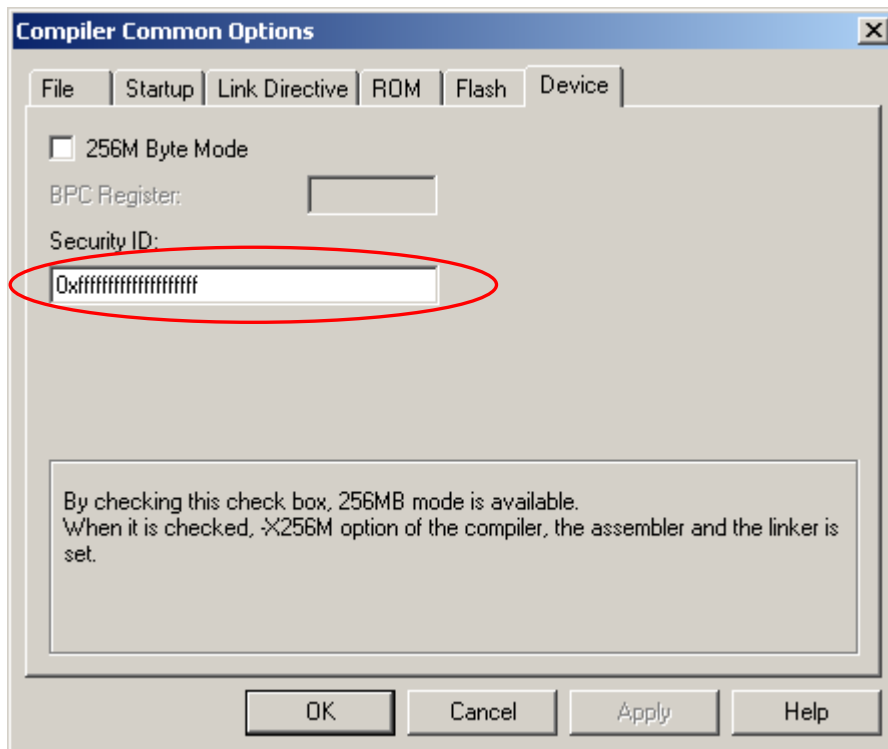

Set the security ID. The security ID is a specific ID code (10 bytes) used for the authentication when the debugger is starting. The security ID is stored at the address 70H–79H in the microcontroller built-in flash memory. The security ID in the flash memory and the ID entered in the configuration dialog are compared when the debugger is starting. When the ID does not match, the debugger cannot be started. Therefore, it is useful to protect the program data in the memory from others.

If you do not need to care about the security, it is recommended to enter "FFFFFFFFFFFFFFFF". (When you erase the data in the flash memory, the ID is set to this value.)

If you forgot the security ID code stored in the address 70H–79H, the debugger (ID850QB) will not be able to start.

In this case, you need to use "WriteEZ5" to erase the built-in flash memory. By erasing the flash memory, the security ID is set to "FFFFFFFFFFFFFFFF".

For details, refer to "[5.4 WriteEZ5](#)".

## 2.4.3 "Preprocessor" Tab

Select "Tool" on menu bar in PM+, then "Compiler Options...".  
Select "Preprocessor" tab, and check "Use C++ Style Comment".

This setting allow you to use the C++ comment using “//”.  
It is useful feature when editing programs.

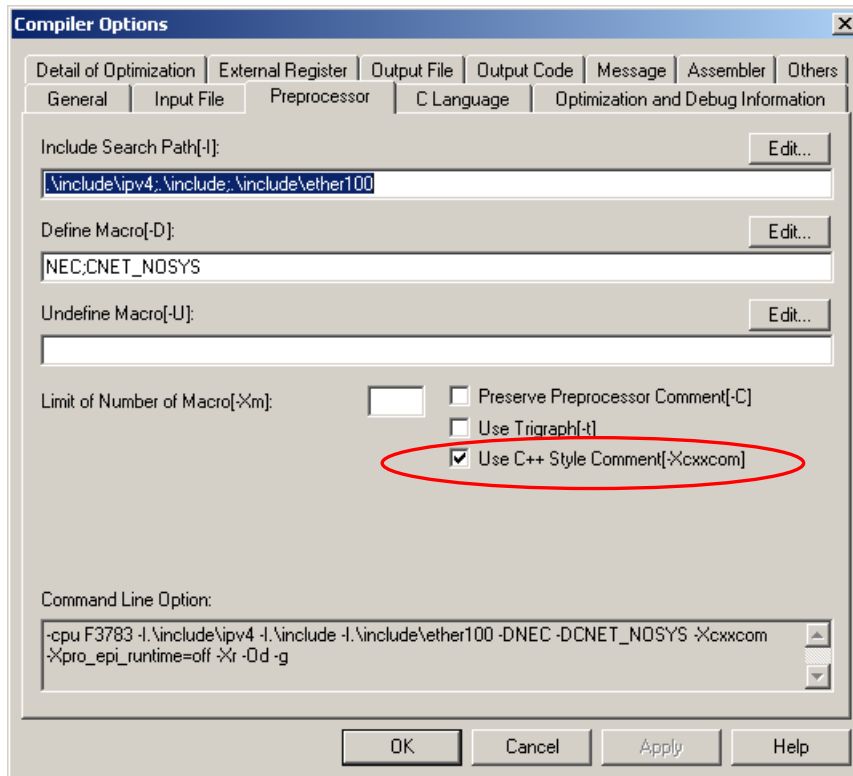

## 2.5 Create Load Module Files

After developing the source code, you have to create load module files by compiling, assembling, and linking. This process is called build.

Click the build button  , or select "Build" on menu bar, then "Build".

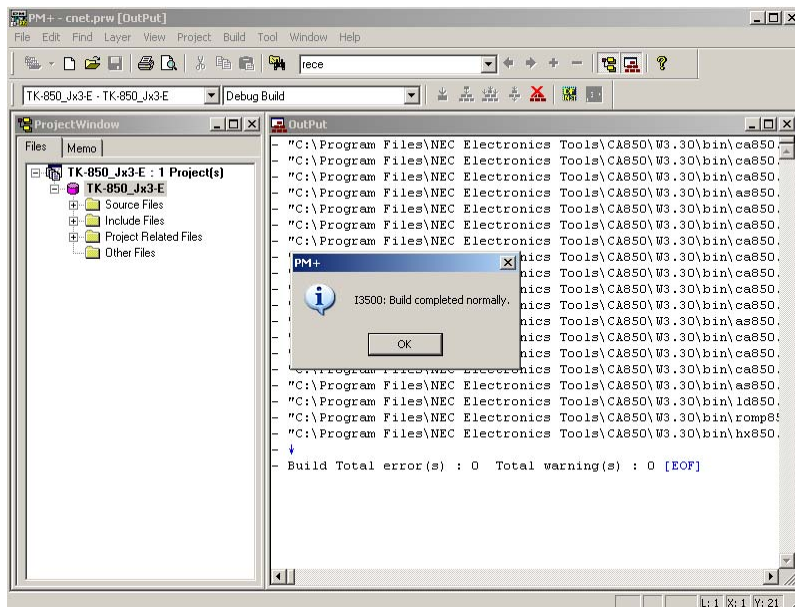
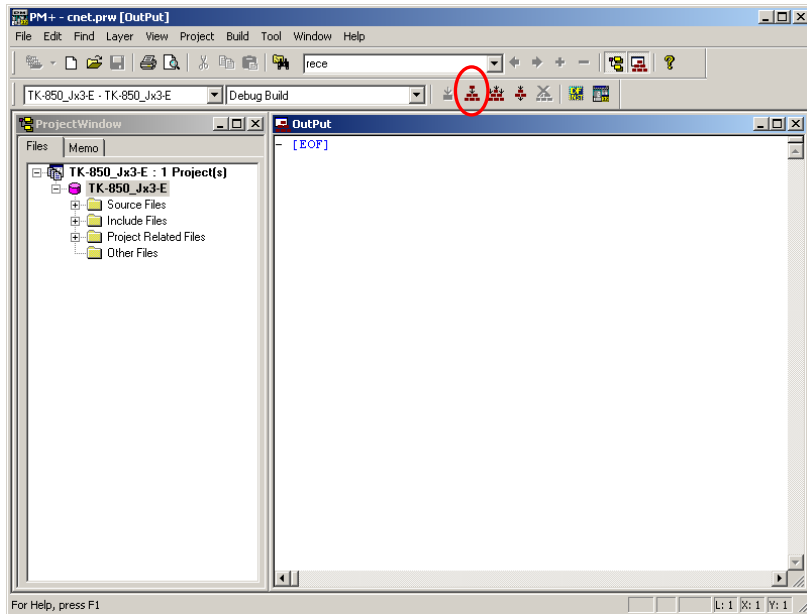

Build has been completed successfully.

**What is build?**

Build is a function that creates an executable file from source files in a project.

PM+ automatically performs compiling, assembling, linking, and other processing actions.

To reduce the time for the build, PM+ detects and compiles/assembles only the files that have been updated from the previous build process.

**What is rebuild?**

Build compiles and assembles only the source files that have been updated from the previous time, whereas rebuild compiles and assembles all the source files.

When setting, such as compiler options, have been changed, you must rebuild instead of build.

## 2.6 Check Debugger Settings

After the build, you should configure the debugger settings.

The debugger settings have been set by the project file as well. However, because those settings are important for debugging, some settings are covered in this section.

Select "Tools" on menu bar, then "Debugger Setting...".

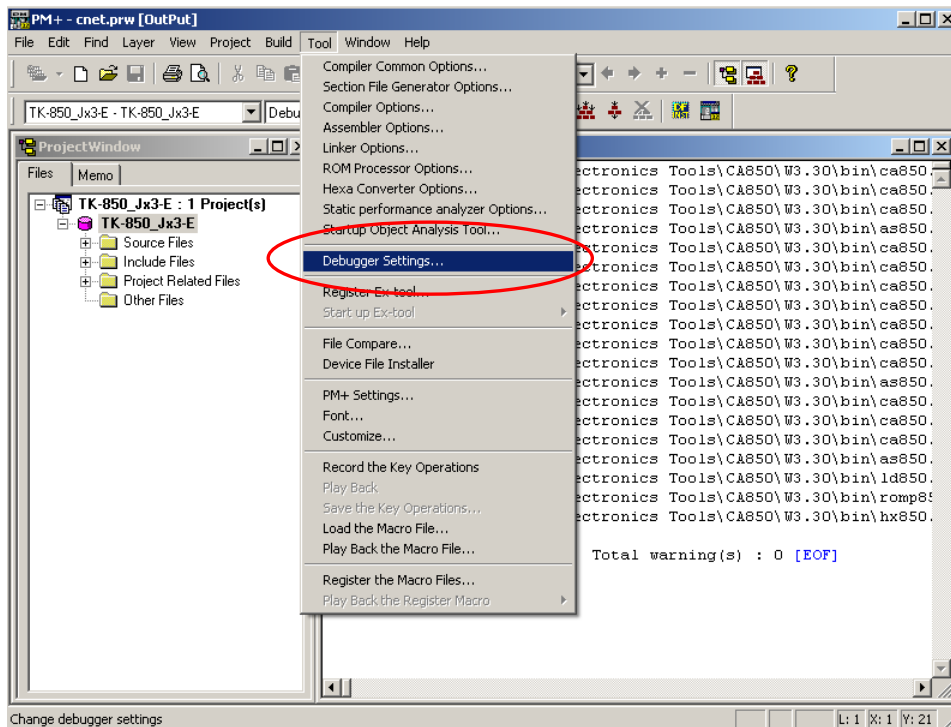

Check if "ID850QB V3.60 V850 Integrated Debugger" is selected on "Debugger".

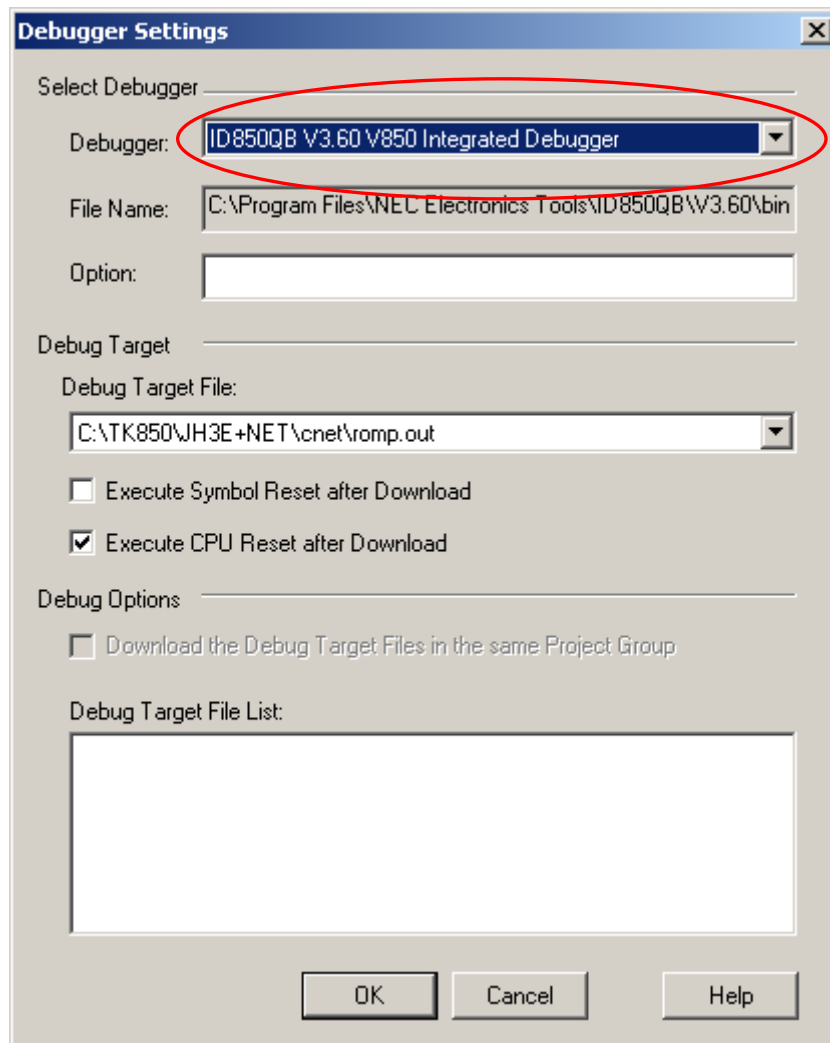

If you cannot select "ID850QB V3.60 V850 Integrated Debugger", select "Project" on menu bar, "Project settings" -> "Tool version settings" -> "Detailsetting" -> then select "ID850QB V3.60".

## 2.7 Check Board Settings

Before connecting the PC and the TK-850/JH3E+NET with USB, you should check the setting of SW1 on the board.

- ① Set the SW1 of the TK-850/JH3E+NET as follows.

SW1

|      |     |
|------|-----|
| Bit1 | OFF |
| Bit2 | ON  |
| Bit3 | ON  |
| Bit4 | ON  |

- ② Set JP1 to 1-2 short.
- ③ After the switch settings are completed, connect the PC to USB1 on TK-850/JH3E+NET with USB cable.

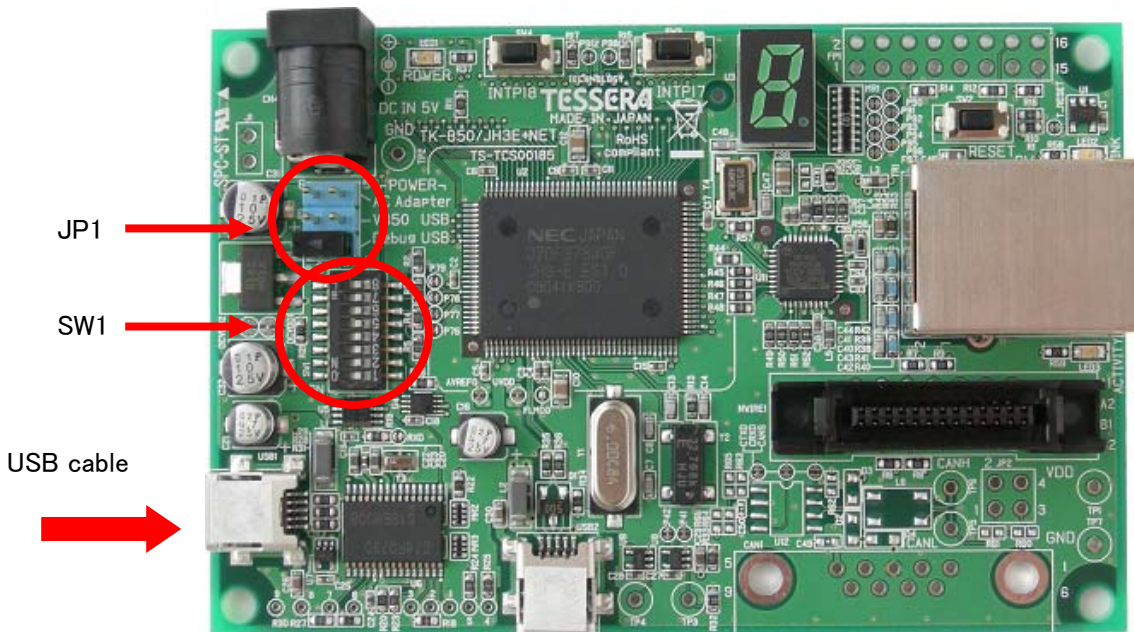

## 2.8 Start Debugger (ID850QB)

Click the debug button  , or select "Build" on menu bar, then "Debug".

If you do not see the debug button, go to "2.7 Check Debugger Settings" for changing the settings.

The steps to start the debugger will be explained below.

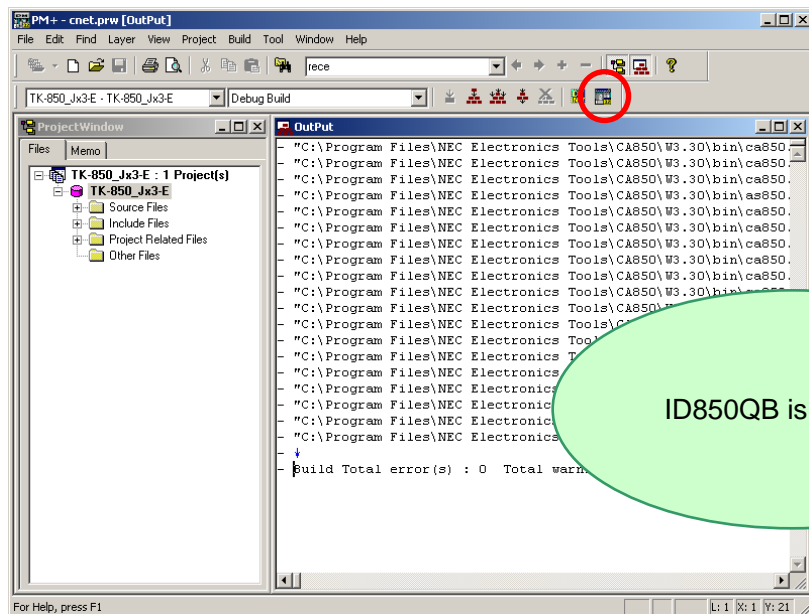

"Configuration" dialog is opened. Follow the settings below and click "OK".

- Enter "6" in "Main OSC"
- Enter "8" in "Multiply rate"
- Enter "FFFFFFFFFFFFFFFF" (F x 20) in "ID Code".
- Select "UARTC0" in "Port" at "Target Device Connection" area then click  .

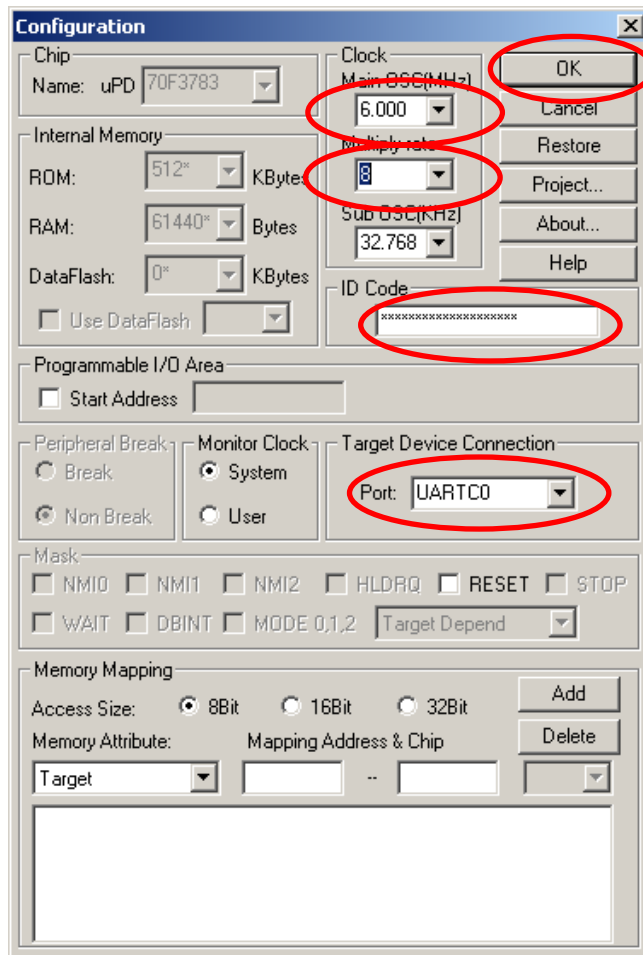

Click  when the confirmation dialog for downloading load module file is opened.

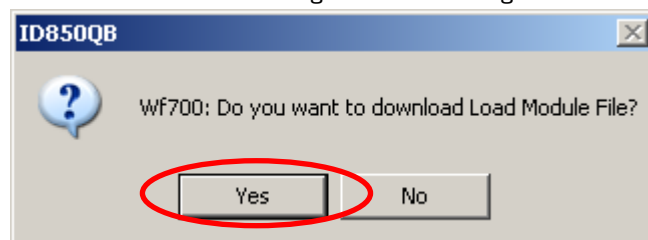

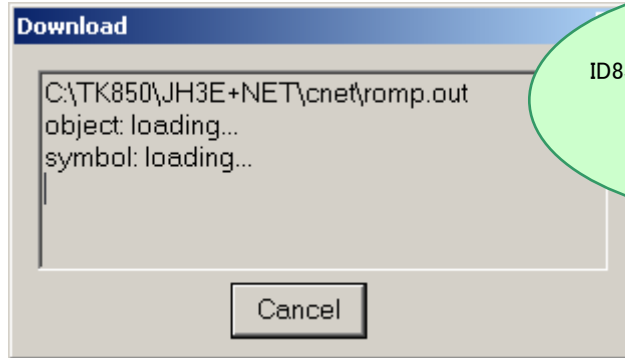

ID850QB starts and downloading the program to flash memory.



When the download is completed, the source code will be displayed

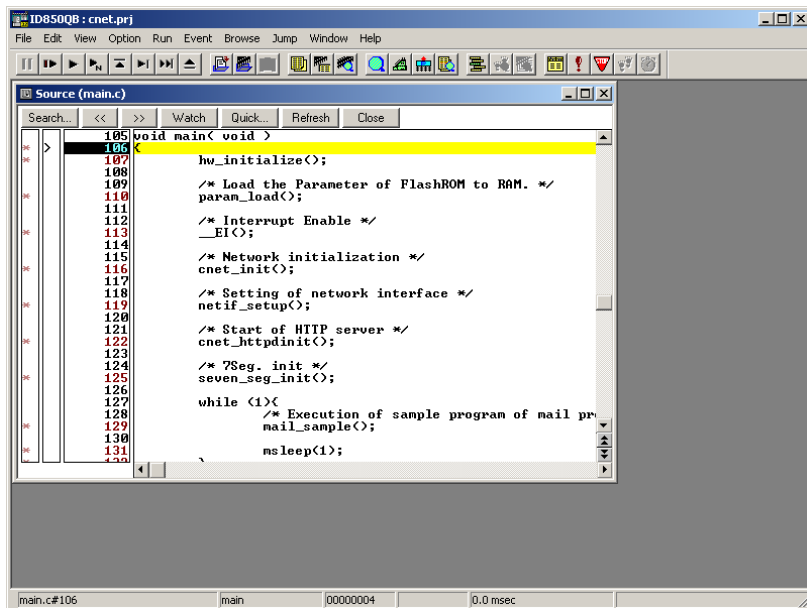

**NOTE:**

Completion of the download does not mean running the programs. Therefore, even though you press switch on the board, it does not make anything happened. To run the sample program demonstration, see "2.9 Run Programs".

## 2.9 Run Programs

Now, you are ready to run the program.

Click the restart button  , or select "Run" on menu bar, then "Restart".

The sample program runs.

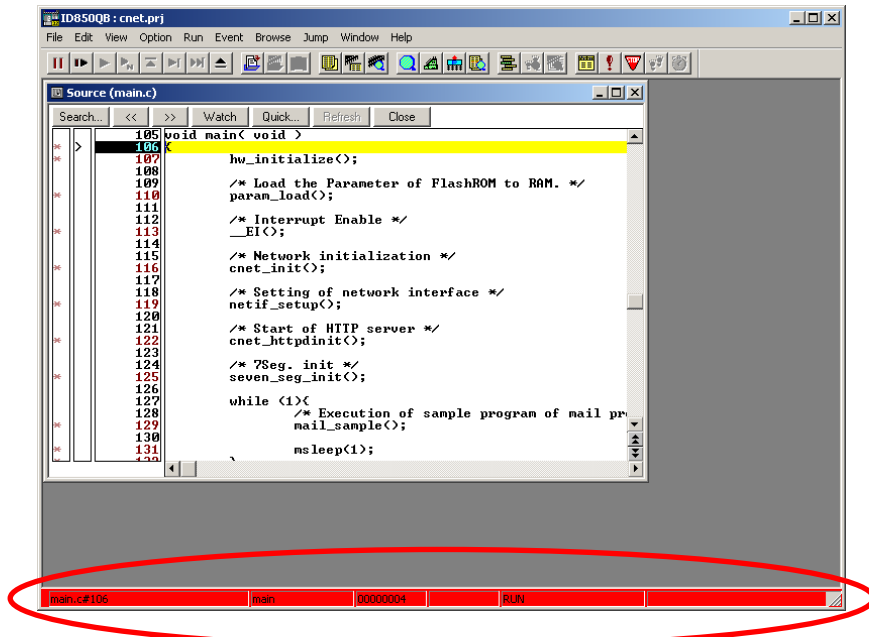
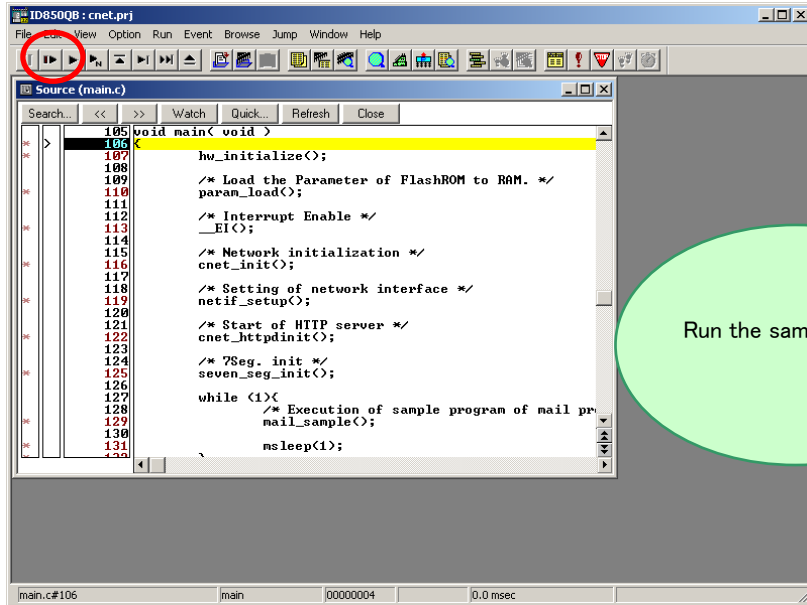

When programs are running, the status bar will be red.

Confirm if 7SegLED (U3) on TK-850/JH3E+NET is lighted.

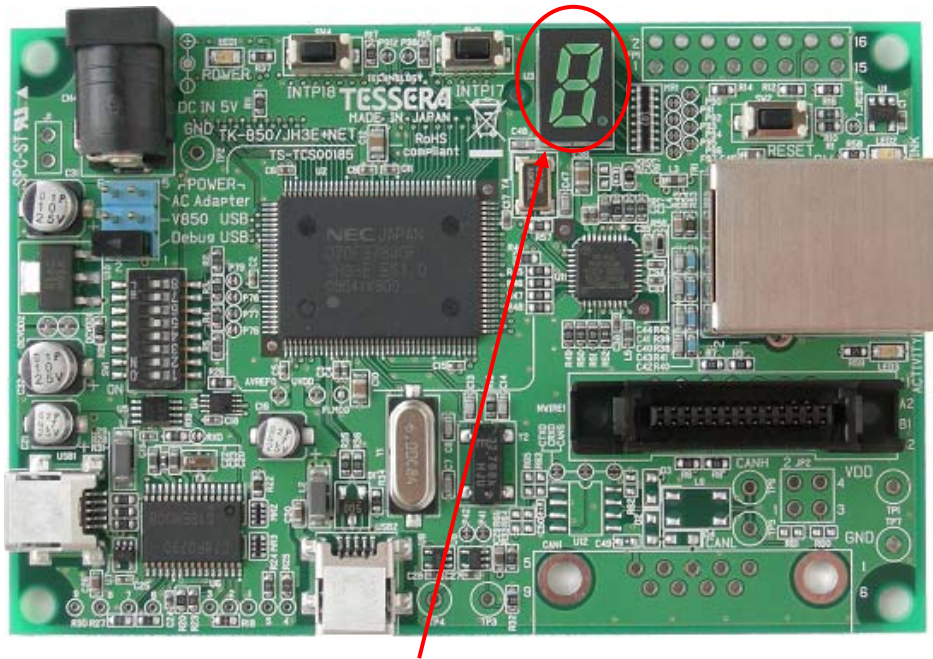

7 Seg LED



You could confirm the sample program is working.

- The programs downloaded by ID850QB cannot use without ID850QB connection.  
For stand-alone operation, write the HEX file by WriteEZ5.  
For more information about the WriteEZ5, refer to "5.4 WriteEZ5" document.

## 2.10 Stop Programs

Now, you are going to stop the program.

Click the stop button , or select "Run" on menu bar, then "Stop".

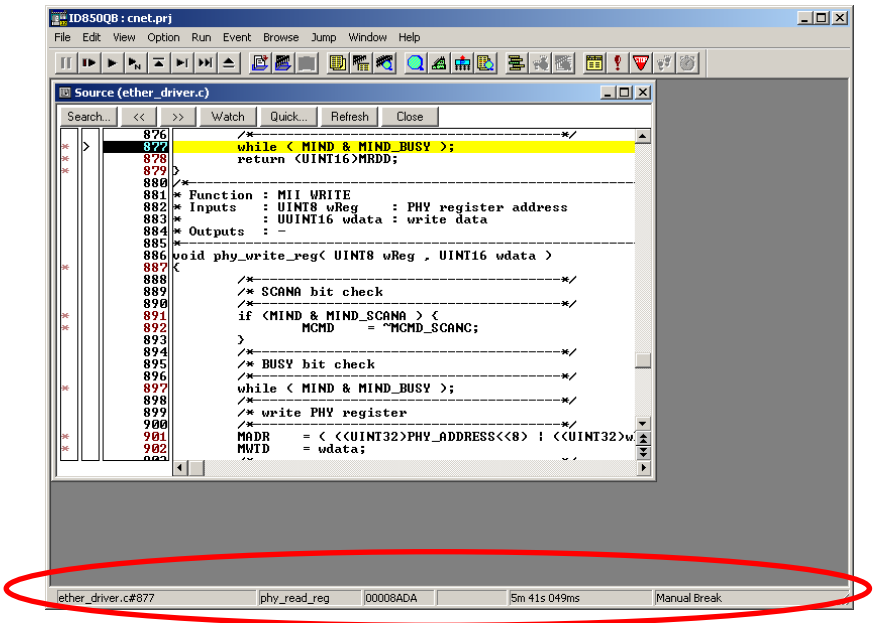
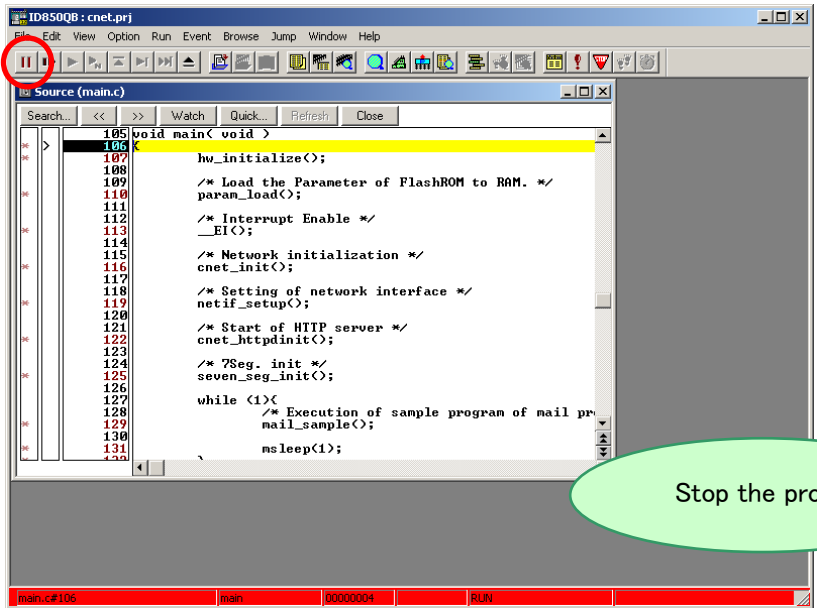

When the program stops, the status bar changes back to the original color.

## 2.11 Close Debugger (ID850QB)

Select "File" on menu bar, then "Exit".

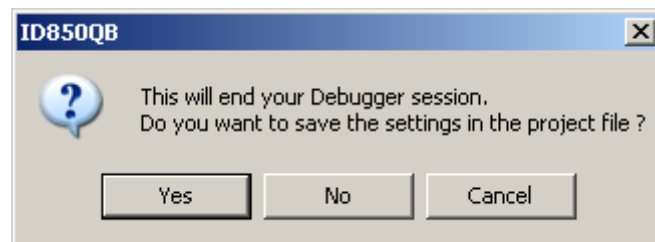
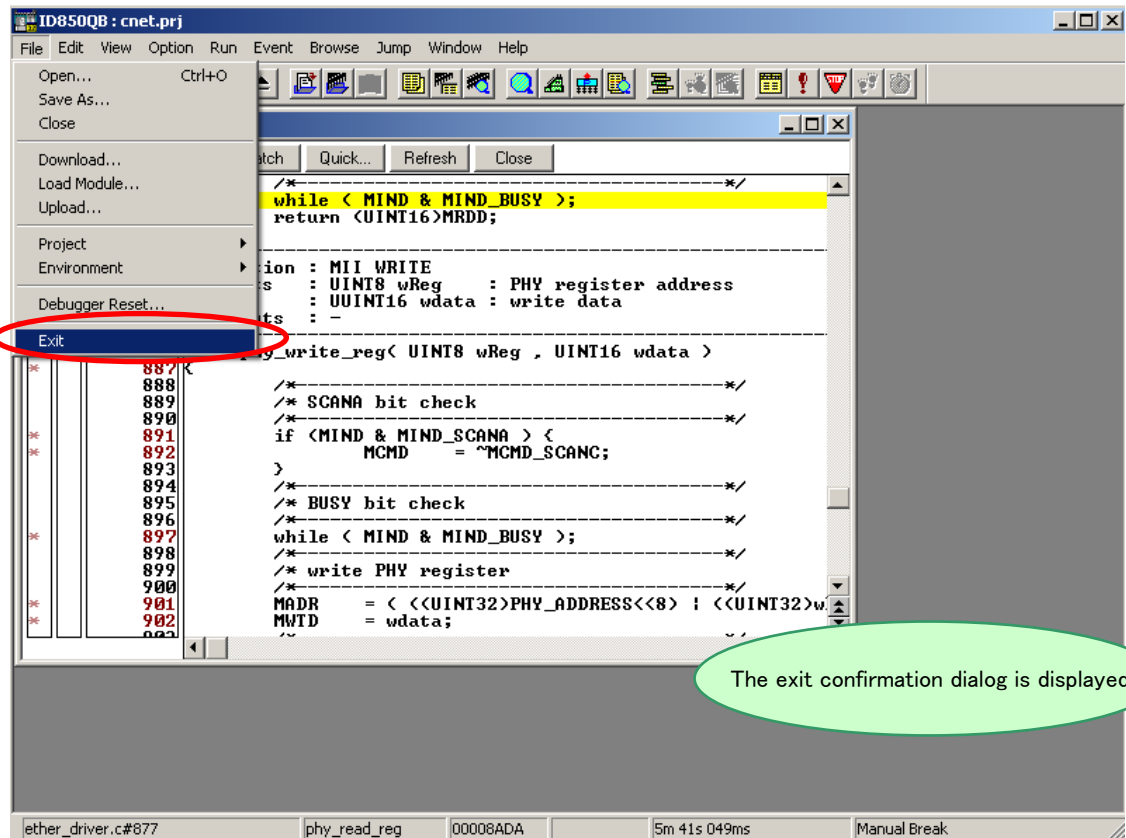

If you click  , it saves the settings in the project file, and then closes the ID850QB. It is recommended to save the settings as it saves the window you used, window size, layout, etc.

If you click  , it does not save the settings and closes the ID850QB.

## 2.12 Quit PM+

Select "File" on menu bar, then "Exit PM+".

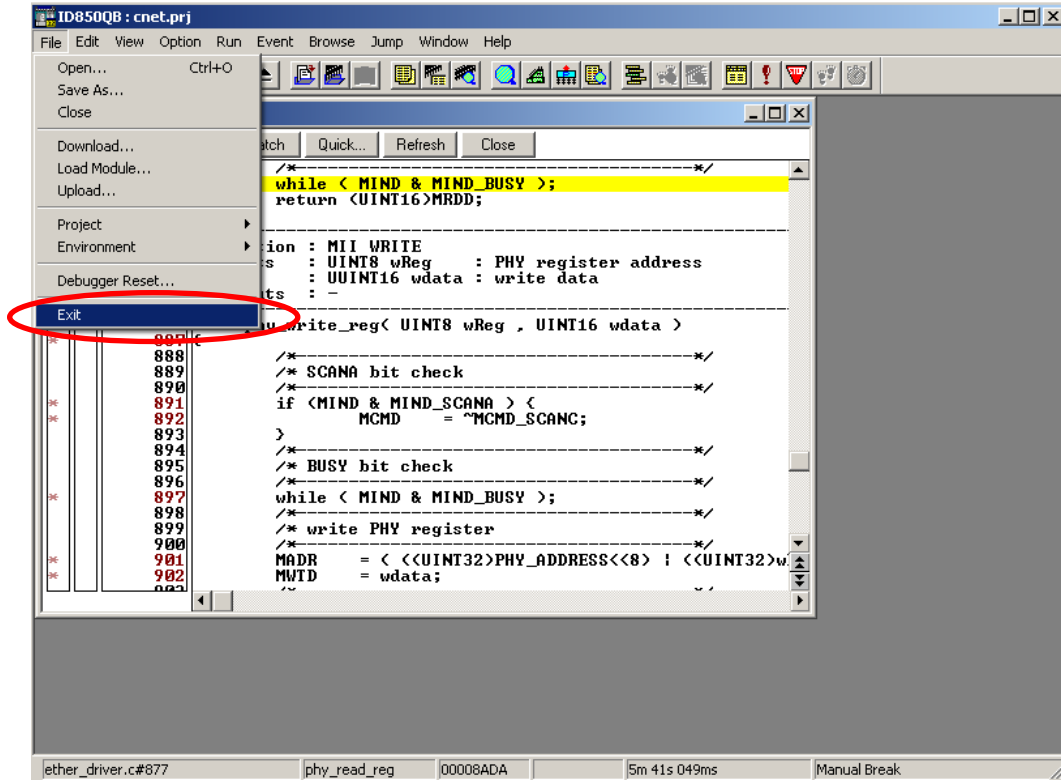

PM+ is closed.

The experiences section ends now.

You can find more information how to use the development tool and information about other useful features in "[Chapter 5 Other Information](#)".

## CHAPTER 3 Hardware Specifications

In this chapter, the hardware of TK-850/JH3E+NET will be explained.

|                      |                                                                                                                                                                                                                                                                         |
|----------------------|-------------------------------------------------------------------------------------------------------------------------------------------------------------------------------------------------------------------------------------------------------------------------|
| Microcontroller      | $\mu$ PD70F3783 ※V850ES/JH3-E                                                                                                                                                                                                                                           |
| Clock                | External main system clock: 48MHz (6MHz x8)<br>Sub-clock: 32.768KHz                                                                                                                                                                                                     |
| Interface            | USB x2 (MINI B connector)<br>Connector for N-Wire (KEL connector)<br>Connector for MINICUBE2 (only pad)<br>Connector for Ethernet (RJ-45, TDK TLA-6T718)<br>Connector for CAN (Connector and other peripheral parts are not mounted.)<br>Expansion connector (only pad) |
| Dimension            | 90mm x 60mm                                                                                                                                                                                                                                                             |
| Power supply voltage | 5V                                                                                                                                                                                                                                                                      |

### 3.1 Layout of hardware functions

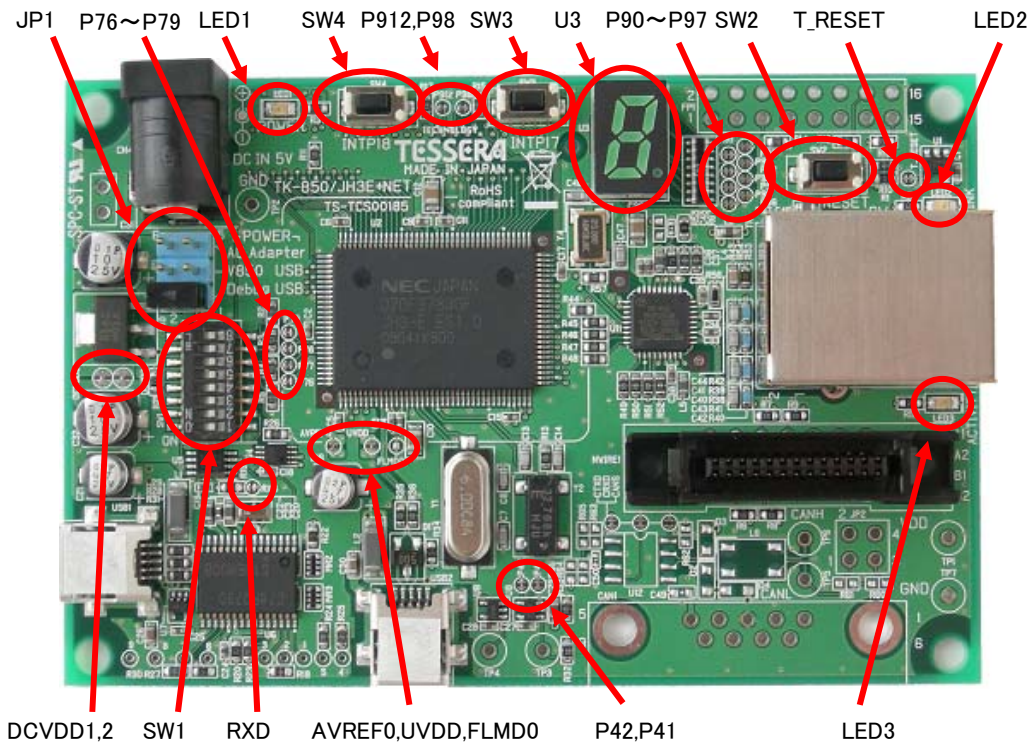

### 3.2 Layout of solder-short pad

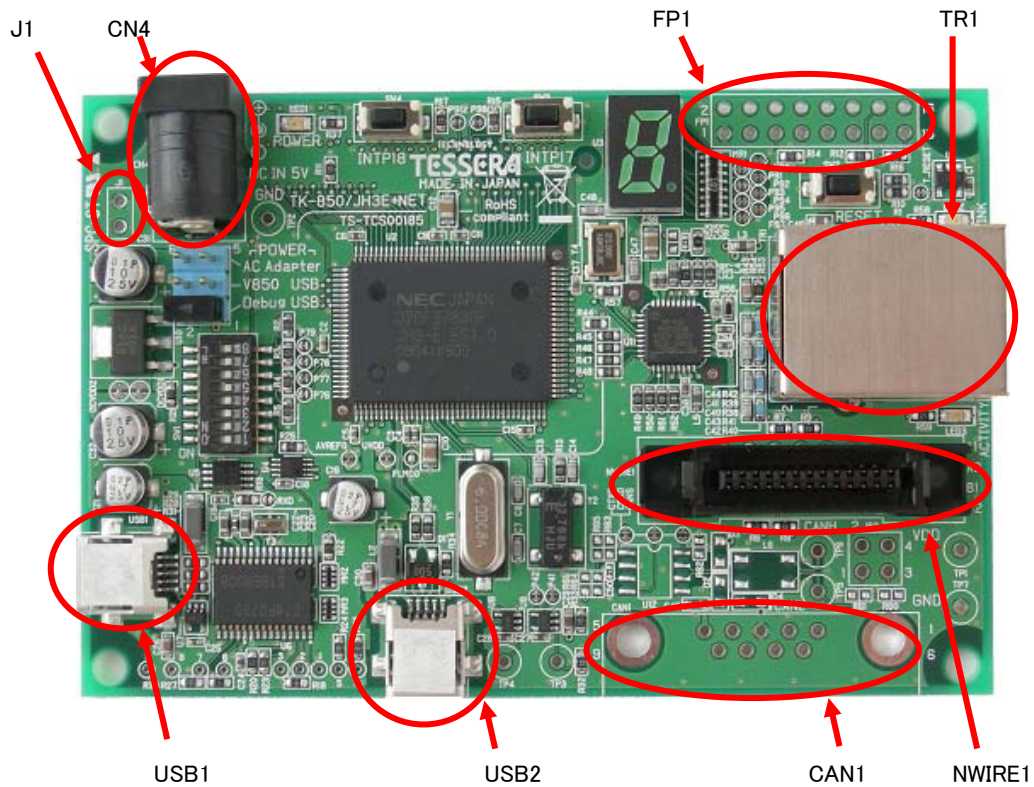

## 3.3 Hardware Functions

### 3.3.1 SW1

The bit 1-4 on SW1 are for mode settings, Bit5-8 of SW1 are connected to "P76/ANI6" ~ "P79/ANI9" for general-purpose input port.

- Set as shown in the following table if you wish to debug using bundled ID850QB through USB1

SW1

|      |     |
|------|-----|
| Bit1 | OFF |
| Bit2 | ON  |
| Bit3 | ON  |
| Bit4 | ON  |

- \* When you debug through USB1, it communicates with the host machine through P30 and P31 pins. Therefore, you cannot use these pins.

- Please change to the following settings when writing it in the flash memory with built-in CPU by using WriteEZ5. (The hardware of WriteEZ5 is built into TK-850/JH3E+NET.)

SW1

|      |     |
|------|-----|
| Bit1 | OFF |
| Bit2 | ON  |
| Bit3 | ON  |
| Bit4 | ON  |

- To run the programs stored in built-in flash memory by WriteEZ5, use following settings and re-supply power.

SW1

|      |     |
|------|-----|
| Bit1 | OFF |
| Bit2 | OFF |
| Bit3 | OFF |
| Bit4 | ON  |

- Please change to the following settings when you connect N-Wire emulator.

SW1

|      |     |
|------|-----|
| Bit1 | OFF |
| Bit2 | OFF |
| Bit3 | OFF |
| Bit4 | ON  |

- Bit5-8 of SW1 is connected with the following terminals CPU.  
There are connecting to pull-up resistor. When the switch is pushed down, it sends the signal of "Low".

SW1

|      |     |
|------|-----|
| Bit5 | P76 |
| Bit6 | P77 |
| Bit7 | P78 |
| Bit8 | P79 |

### 3.3.2 SW2

This is the reset switch. You can reset the microcontroller by pressing this switch.

### 3.3.3 SW3 (INTP17)

SW3 is the push switch connected to " P98/TENC01/INTP17/A8" pin in CPU. There are connecting to pull-up resistor. When the switch is pushed down, it sends the signal of "Low".

### 3.3.4 SW4 (INTP18)

SW4 is the push switch connected to " P912/TOAB1OFF/INTP18/A12" pin in CPU. There are connecting to pull-up resistor. When the switch is pushed down, it sends the signal of "Low".

### 3.3.5 LED1 (POWER)

This is the POWER LED. It is lighted when it gets power supply.

### 3.3.6 LED2, LED3

The table shows the status of Ethernet transceiver.

|      | Display  | Function            |
|------|----------|---------------------|
| LED2 | LINK     | Link ON Indication  |
| LED3 | ACTIVITY | Activity Indication |

### 3.3.7 U3(7seg LED)

7seg LED of U3 can be lit with P90–P97.

Please set the port mode to the output and output “Low” signal from the port.

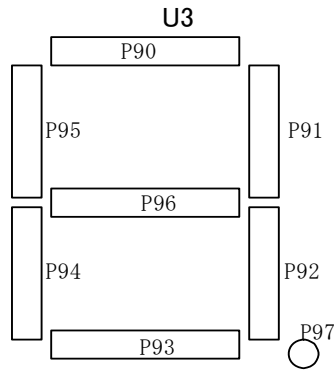

The figure of 0–9 can be displayed by writing the following values in P9 register.

Example of displayed figure and set data.

|   |      |   |      |
|---|------|---|------|
| 0 | 0xC0 | 5 | 0x92 |
| 1 | 0xF9 | 6 | 0x83 |
| 2 | 0xA4 | 7 | 0xf8 |
| 3 | 0xB0 | 8 | 0x80 |
| 4 | 0x99 | 9 | 0x98 |

### 3.3.8 JP1

JP1 are the jumper switch pin to select power supply.

| JP1       |                                                                          |
|-----------|--------------------------------------------------------------------------|
| 1–2 short | It is supplied power from USB1 connector(for debug).                     |
| 3–4 short | It is supplied power from USB2 connector(for V850ES/JH3–E internal USB). |
| 5–6 short | It is supplied power from AC adaptor (+5V) connected to CN4.             |

### 3.3.9 CN4

CN4 is the power supply connector of the AC adaptor.

You can supply the power by setting the JP1 to 5–6 short and connect 5V AC adaptor.

### 3.3.10 J1

This is the connector for external power supply.

### 3.3.11 NWIRE1 Connector

These are connector for N-Wire emulator.

It can connect N-Wire emulator of IE-V850E1-CD-NW etc.

The connector from KEL Corp. "8830E-026-170S" is mounted on NWIRE1.

### 3.3.12 FP1

This is the interface for connecting MINICUBE2.

As a connector is not mounted, you need to solder 16pin connector ("FFC-16BMEP1" from Honda Tsushin Kogyo Co., Ltd.) on FP1.

### 3.3.13 USB1

This is the USB interface for debugging.

You can use this when you need to debug or make serial communication using P30 and P31.

### 3.3.14 USB2

This is V850ES/JH3-E built-in USB interface.

### 3.3.15 CAN1

This is the interface for CAN communication.

Connector and other peripheral parts are not mounted.

### 3.3.16 TR1

This is the interface for Ethernet communication.

TLA-6T718 from TDK Corp. is used for RJ-45 connector.

LAN8700C from SMSC is used for Ethernet transceiver.

### 3.4 solder-short pad label

When using a circumference board connector (CN1) without using a circuit on board, in order to separate a circuit on board, the terminal of CPU can be customized by making the pad for solder short opening.

Pad for solder-short has shape like the figure below.

When you make an open circuit, cut the narrow part of the Pad with a knife.

To make short circuit, join the separated Pad with a soldering iron etc.

Solder-short pad  
(opened shape)



Solder-short pad  
Shorted shape



| Solder-short pad name | State when shipping it | Connection                                                 |
|-----------------------|------------------------|------------------------------------------------------------|
| P90~P97               | Short                  | 7SegLED                                                    |
|                       |                        | Open when using it for other usages                        |
| FLMD0                 | Short                  | FLMD0 to P37 on CPU                                        |
|                       |                        | Short When built-in flash memory is rewritten by self      |
| AVREF0                | Short                  | VDD<->AVREF0                                               |
|                       |                        | Open when AVREF0 is driven by other voltages.              |
| DCVDD1,2              | Short                  | VDD<-> Regulator output                                    |
|                       |                        | Open, when you supply the power from CN1.                  |
| UVDD                  | Short                  | VDD<->UVDD                                                 |
|                       |                        | Open when UVDD is driven by other voltages.                |
| RXD                   | Short                  | P30/TCDD0                                                  |
|                       |                        | Open when P30 isn't used for USB1 communication interface. |
| P76~P79               | Short                  | SW1, 5-8bit                                                |
|                       |                        | Open when P76~P79 isn't used for general-purpose input SW  |
| P98                   | Short                  | P98 <-->SW3                                                |
|                       |                        | Open when using it for other usages                        |
| P912                  | Short                  | P912 <-->SW4                                               |
|                       |                        | Open when using it for other usages                        |

|         |       |                                                       |
|---------|-------|-------------------------------------------------------|
| P42     | Short | P42<--> USB D+ pull-up signal pin.                    |
|         |       | Open when you don't use USB D+ pull-up signal.        |
| P41     | Short | P41<--> USB D+ pull-up enable signal pin.             |
|         |       | Open when you don't use USB D+ pull-up enable signal. |
| T_RESET | Short | 4Pin U2 <--> T_RESET signal.                          |
|         |       | Open when the Reset IC isn't used for.                |

## CHAPTER 4 Troubleshooting

This chapter describes how to solve troubles you may face.

### 4.1 If you cannot find USB driver when you connect PC to the kit

#### Check Point 1

If you use USB hub, do not use it. (USB hub is not supported)

#### Check Point 2

Check if you installed "NEC Electronics Starter Kit Virtual UART Driver" in "[1.4 Installation of USB Driver](#)". If not, install the driver.

#### Check Point 3

If above 2 check points are confirmed, disconnect the USB cable from PC and re-connect again.

### 4.2 Error when you start the debugger

There could be several reasons to make errors happen.

The solving processes differ depending on errors. Please check the error message first.

The solving processes for each error are as follows.

#### 4.2.1 "Can not communicate with Emulator..." (F0100 or A0109)

##### Check Point 1

If you use USB hub, do not use it. (USB hub is not supported)

##### Check Point 2

Check if the settings of switches on the kit are correct with referring "[2.7 Check Board Settings](#)".

##### Check Point 3

Confirm the USB driver installation with referring to "[1.4 Installation of USB Driver](#)".

##### Check Point 4

If above 3 check points are confirmed, close the debugger and disconnect the USB cable from PC. Re-connect USB cable properly to both the PC and the kit, and then re-start the debugger.

## 4.2.2 "Incorrect ID Code." (Ff603)

This error occurs when the security ID stored on microcontroller built-in flash memory is different from the ID code you entered at the start of debugger.

Security ID entry area at the start of debugger



### Check Point 1

Enter correct security ID and click OK on the configuration window.

### Check Point 2

If you forgot the security ID, you have to erase the microcontroller built-in flash memory. Before erasing, check if you actually set the security ID with referring to "[2.5 Set Options](#)". Also remember the code you set for the security ID.

After this, erase the flash memory with referring to "[5.4 WriteEZ5](#)".

## 4.3 Monitor memory cannot be accessed. (F0c72)

### Check Point 1

Check if the settings of switches on the kit are correct with referring "[2.7 Check Board Settings](#)".

### Check Point 2

Erase the flash memory with referring to "[5.4 WriteEZ5](#)".

### Check Point 3

If above 2 check points are confirmed, disconnect the USB cable from PC and re-connect again. And, retry starting the debugger.

## CHAPTER 5 Other Information

This chapter explains some useful operation techniques of development tools and circuit diagram of the kit for developing of user programs.

[5.1 Create a new workspace \(project\)](#)

[5.2 Register additional source file](#)

[5.3 Debugger tips](#)

[5.4 WriteEZ5](#)

[5.5 Parts list, Circuit diagram](#)

## 5.1 Create a new workspace

Now, create a new workspace and project.

PM+ allows you to create a new workspace with following "New WorkSpace" dialog.

Select "File" on PM+ menu bar, then "New Workspace...".

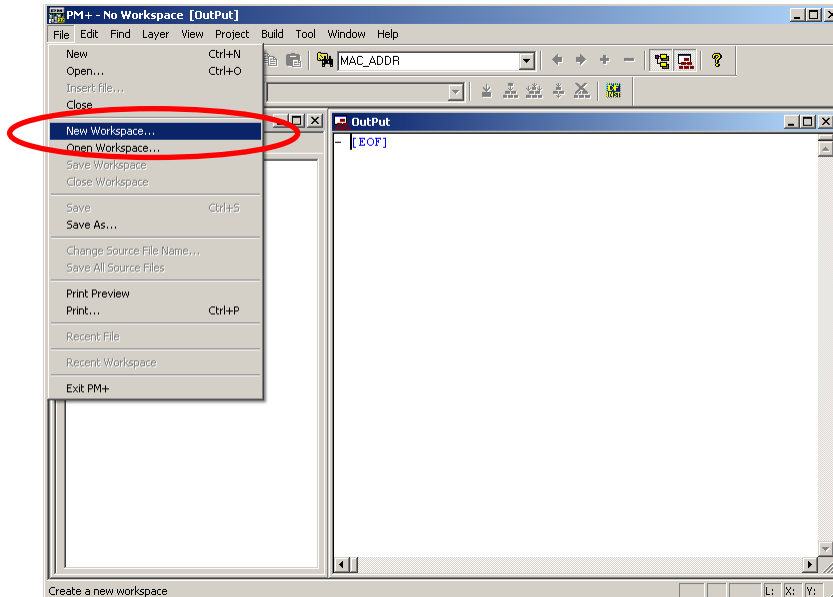

"New WorkSpace" dialog opens



<Description of items>

**Workspace File Name:**  
 -> Specify the name of the workspace file that manages the project files.  
 .prw is automatically suffixed as the file type.  
 A project file (.prj) of the same name is simultaneously created.

**Folder:**  
 -> Specify the folder for saving the workspace file by writing its absolute path.  
 This item can be selected from a reference dialog box by pressing the **Browse...** button.

**Project Group Name:**  
 -> Specify this item if wishing to manage multiple projects together in function units.  
 If nothing is specified, this item is the same as the workspace file name.

**Microcontroller Name:**  
 -> Specify the name of the microcontroller to be used.

**Device Name:**  
 -> Specify the name of the device to be used.

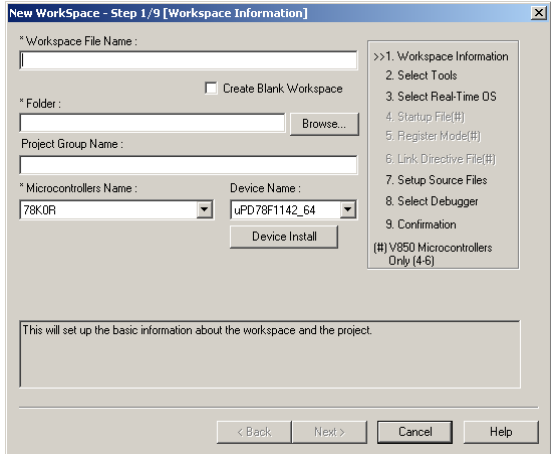

The concrete information set here is described on the following pages

Input the workspace information setting as follows.

Workspace file name

→ test

Folder

→ C:\TK850\test

Project Group Name

→ (no input)

Microcontroller Name

→ V850 Series

Device Name

→ uPD70F3783

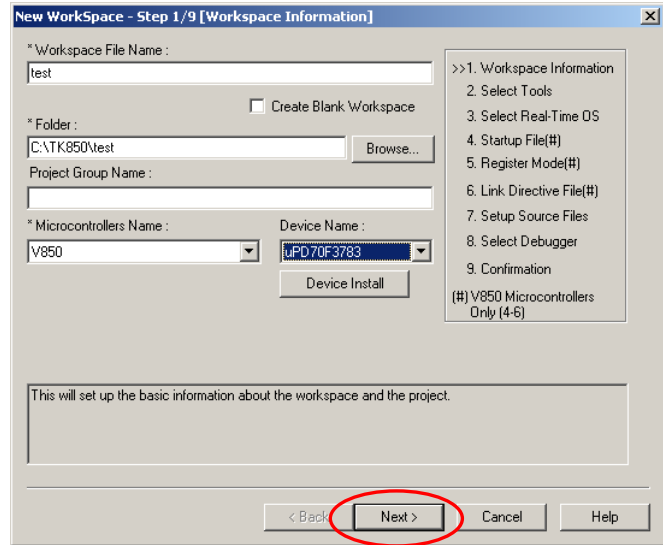

Click **Next >** button

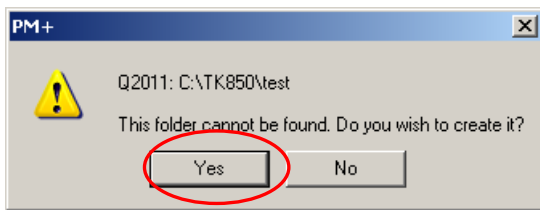

Click **Yes** button

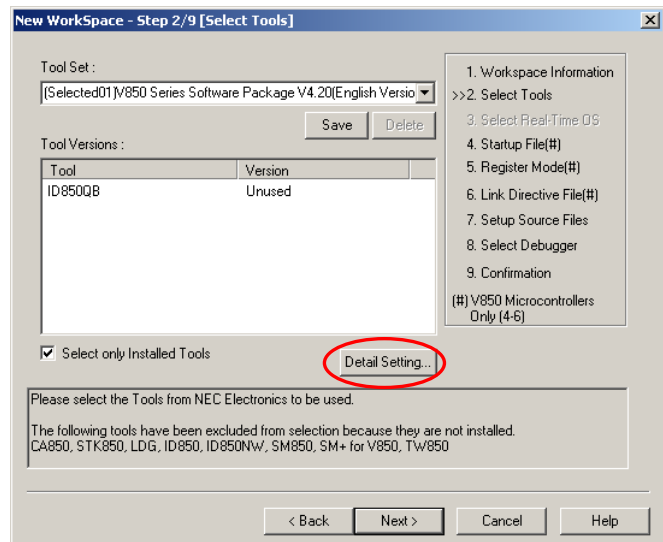

Click **Detail Setting** button

Set the version of tools as follows.  
CA850: **W3.30**  
ID850QB: **V3.60**

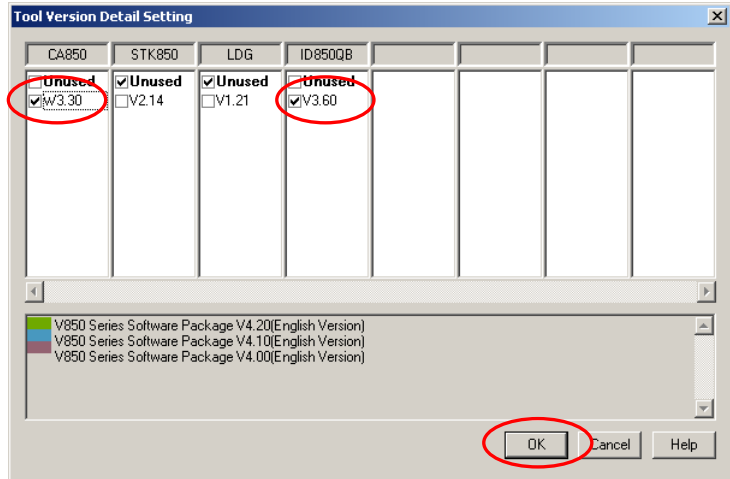

Select tools as above screenshot, then click **OK** .

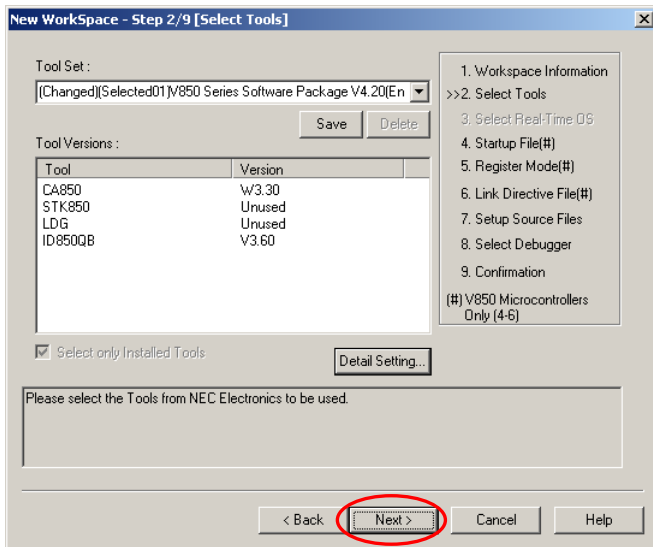

Click **Next >**



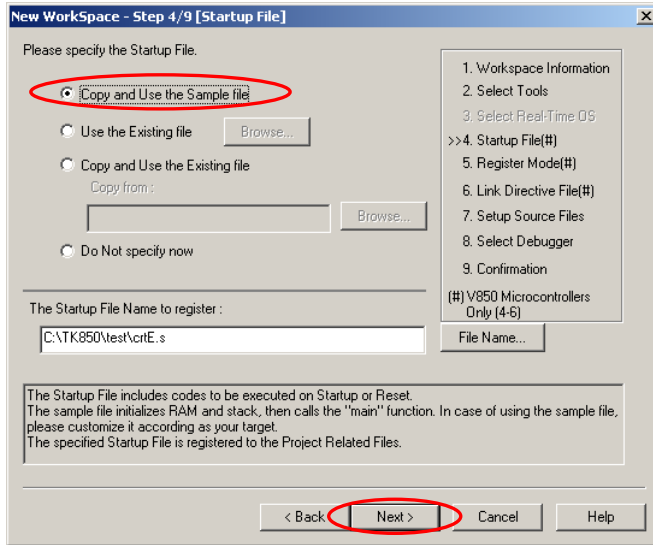

Select the "Copy and Use the Sample file".

Press the **Next >** button.

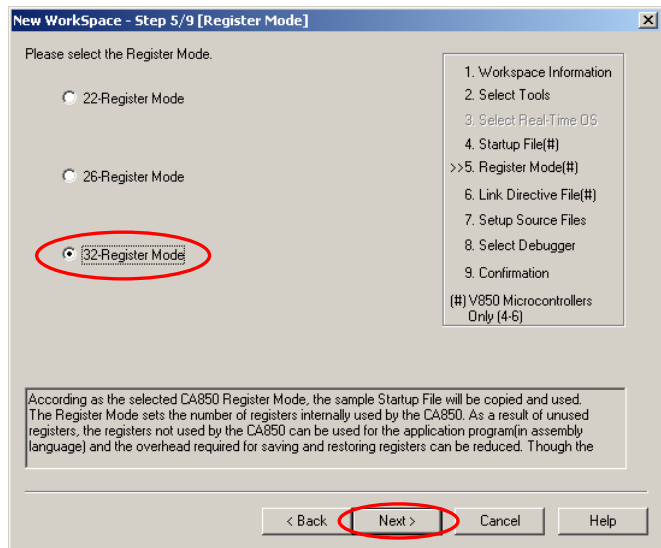

Select the "32-Register Mode".

Press the **Next >** button.

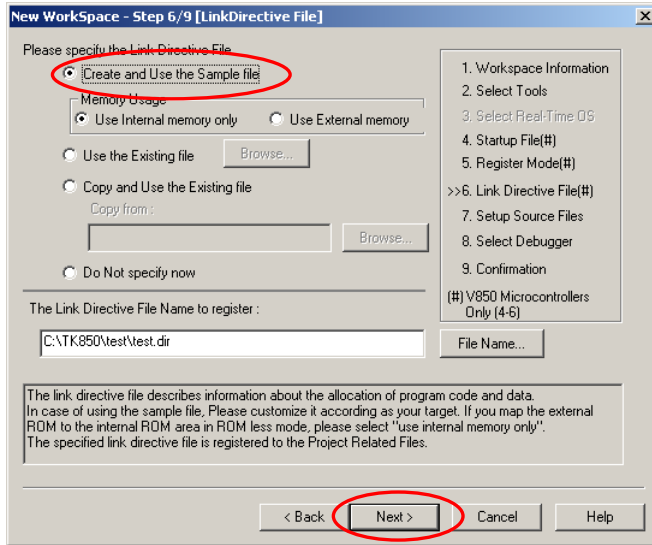

Select the "Create and Use the sample file"

Press the **Next >** button.

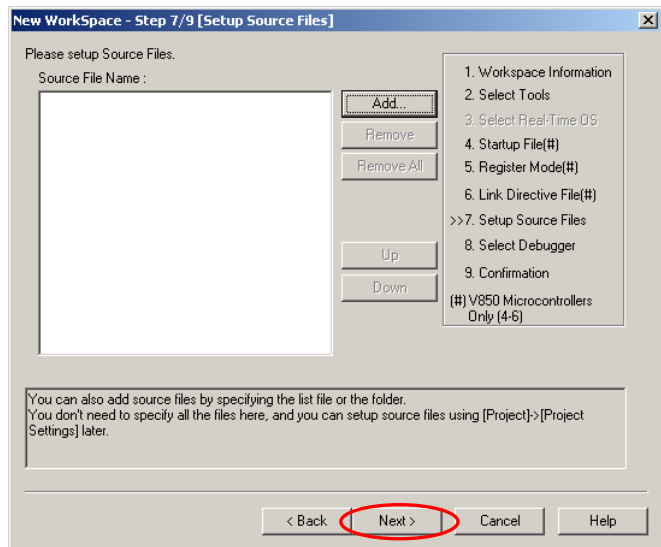

Press the **Next >** button.



Select the "ID850QB V3.60"

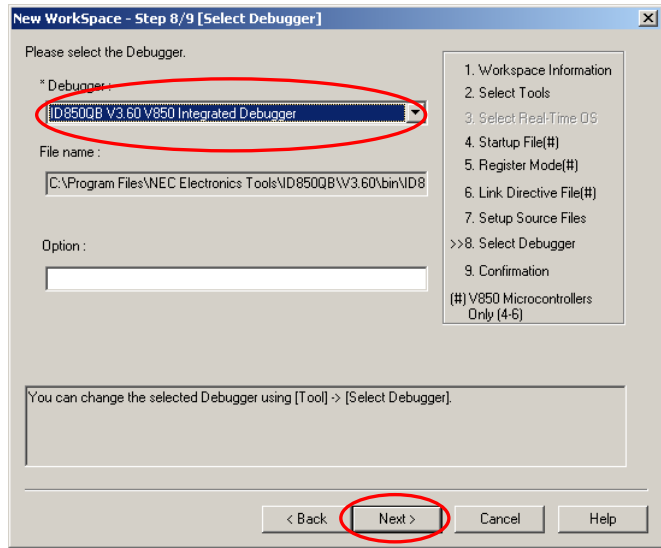

Press the **Next >** button.

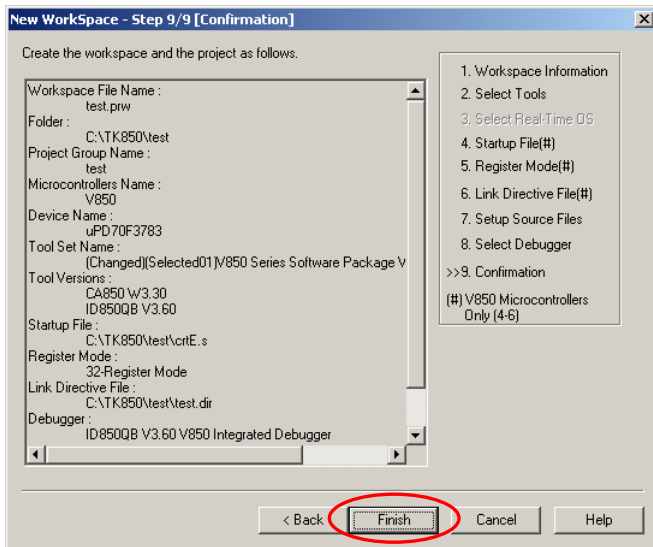

Press the **Finish** button.

Check the project information setting contents.



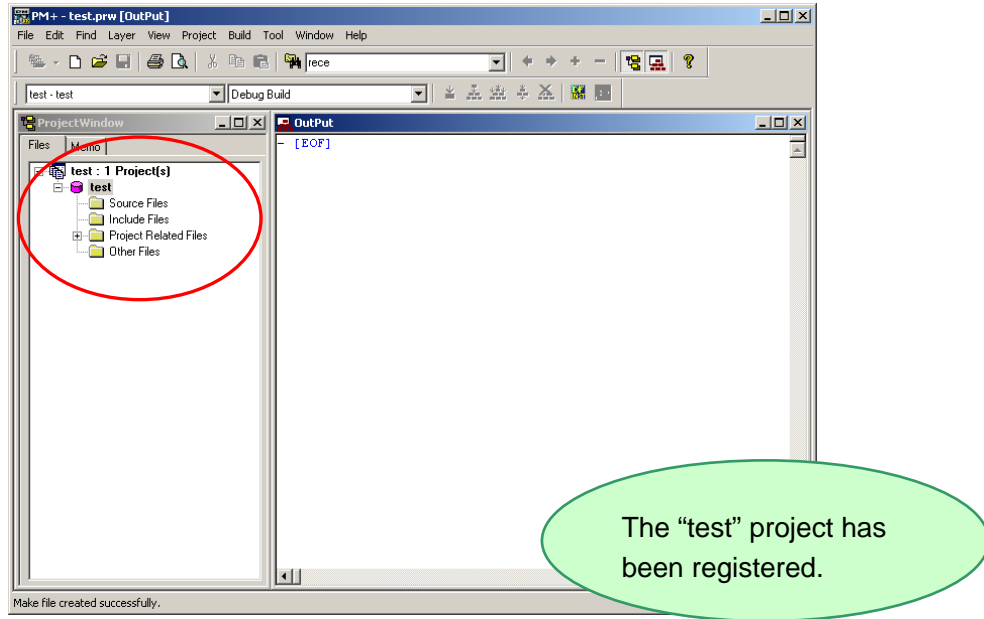

This completes workspace and project creation.

Additional source files can be registered at any time thereafter.

➡ For details, refer to ["Registering additional source files"](#).



Next, setup the security ID

In the PM +, [Tool] → [Compiler common Options...] is selected.

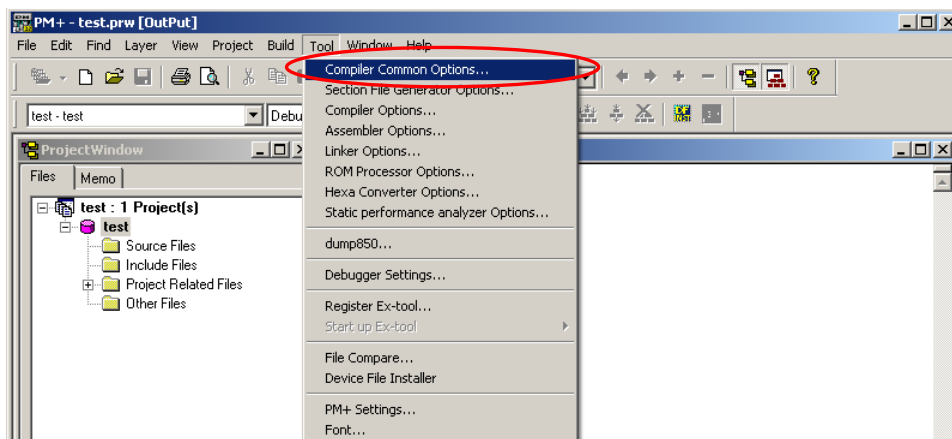

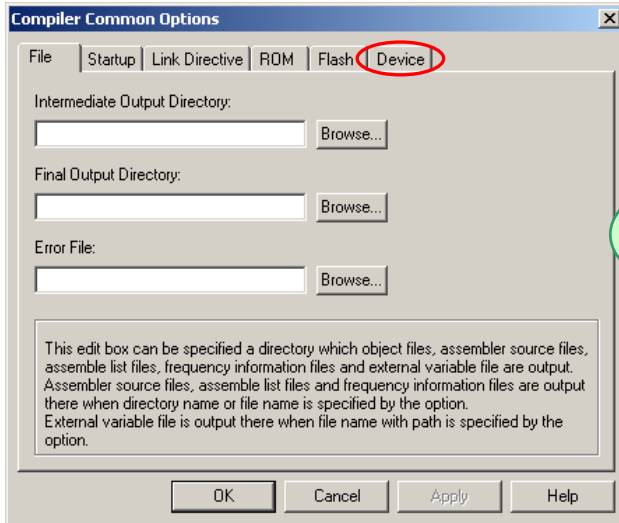

Compiler Common Options setting is open.

Click the "Device" tab.

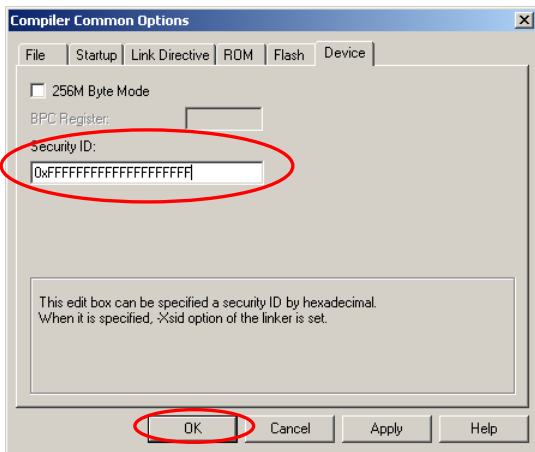

The actualities of "FFFFFFFFFFFFFFFF" (20 of F) are taken if there is no problem in the value of ID in security.

Press the **OK** button.

Security ID settings are complete

## 5.2 Register additional source file

Now, register additional source files.

The following example shows the additional registration of source files "b.c" and "c.c" with source file "a.c" already registered.

Place the cursor on the source file in the Project window of PM+, and select [Add Source Files...] displayed in the right-click menu.

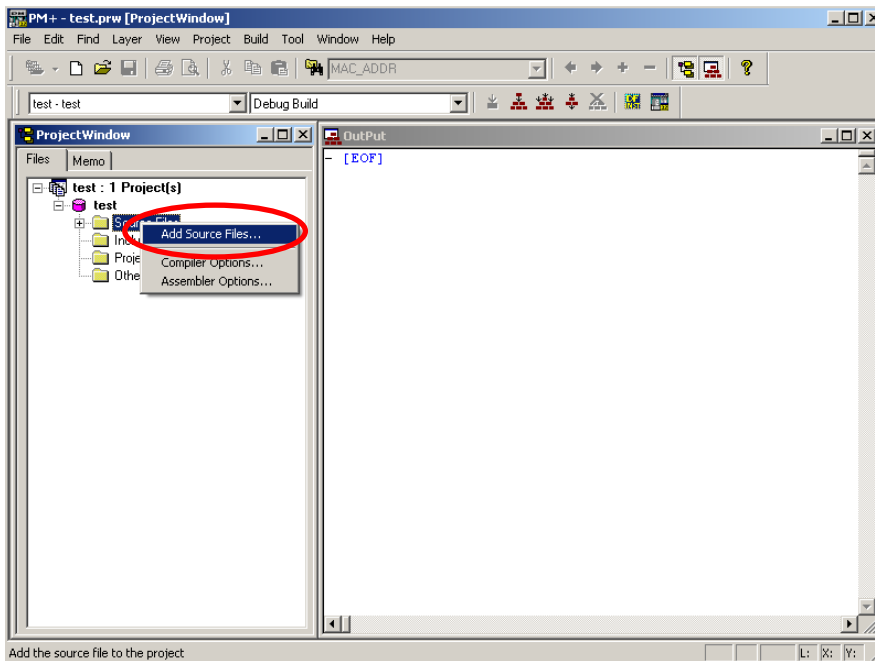

Select source files "b.c" and "c.c", then click

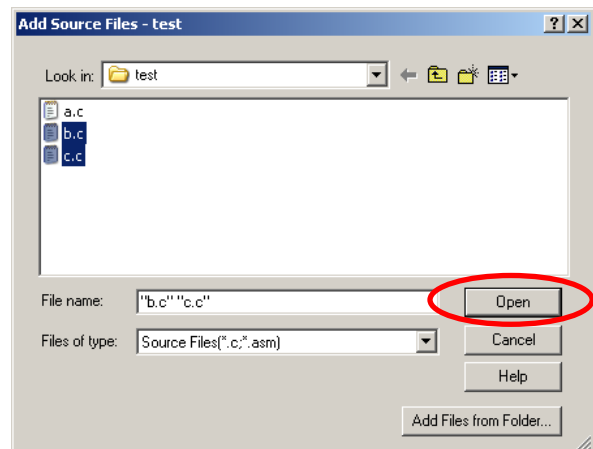

Multiple source files can be selected by clicking them with pressing  key.



Source file "b.c" and "c.c" are additionally registered to the project.

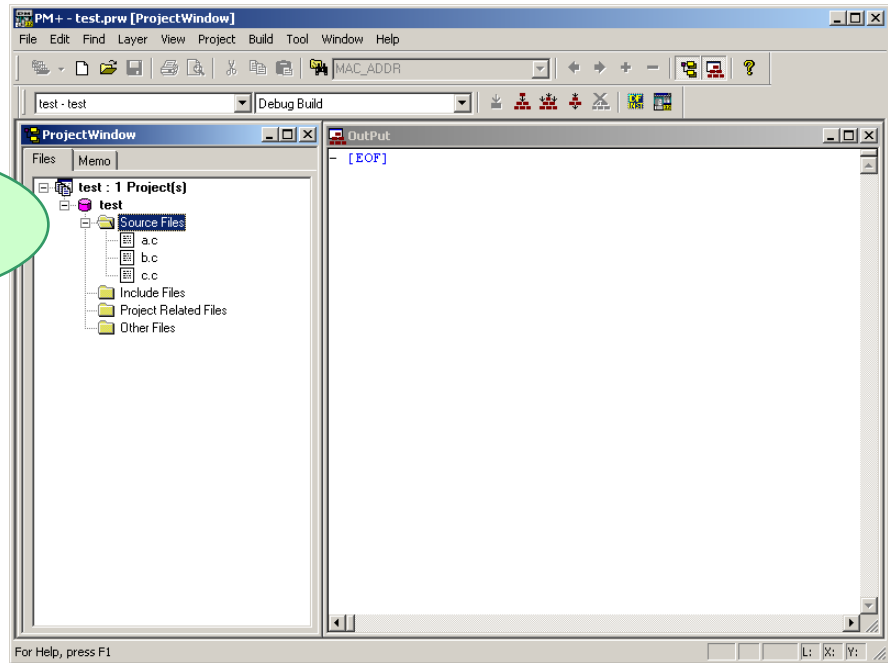

## 5.3 Debugger tips

This section describes some useful techniques for the debugger (ID850QB).

### 5.3.1 Change display of buttons

Execution controls (run, stop, step-in debugging, reset, etc) and opening functional window can be made by below buttons. However, it could be difficult to know which button does what.



In this case, select "Options" on menu bar, then "Debugger Options". Check "Pictures and Text" on setting area.



With this setting, the buttons display the text as well, so that it is easier to know what they are.



### 5.3.2 Display source list and function list

When you wish to see source file list or function list, select "Browse" on menu bar, then "Other" -> "List" to open the list window. The information in the windows is synchronized. Therefore, it is not just for referring to the list, but it is useful when you wish to update files or functions.

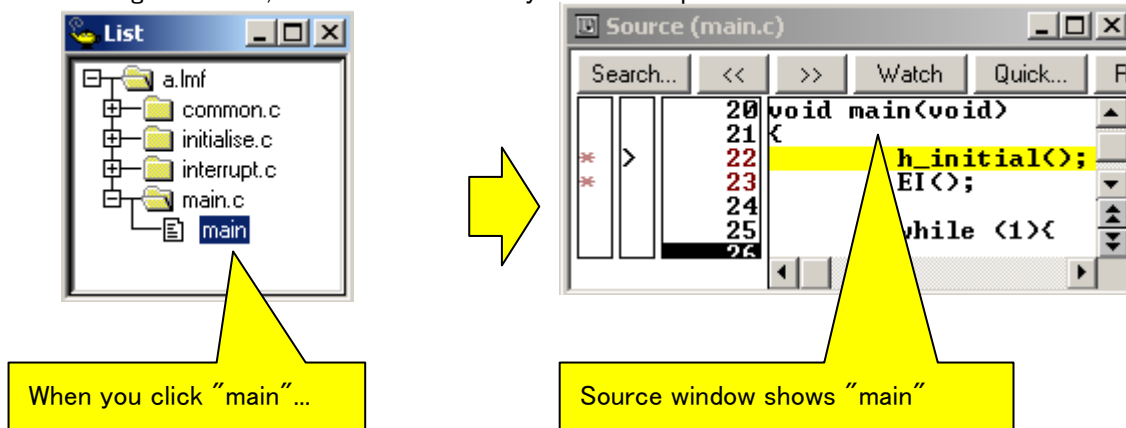

### 5.3.3 Set/delete breakpoints

Breakpoints are executed by clicking lines in which " \* " is displayed

"B" is displayed in the line where a breakpoint is set.

Breakpoints are deleted by clicking "B".

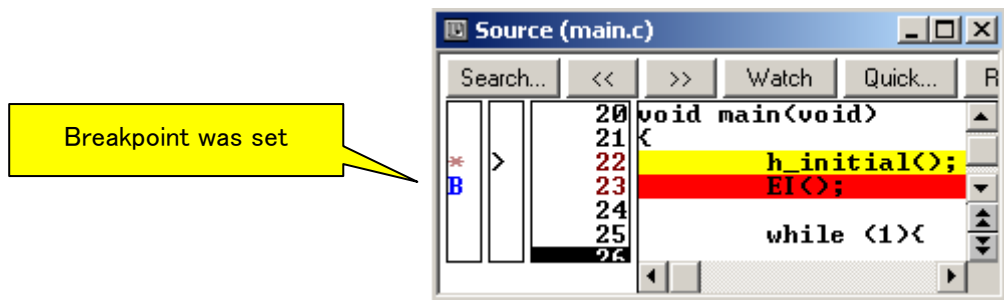
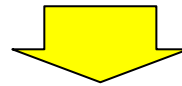
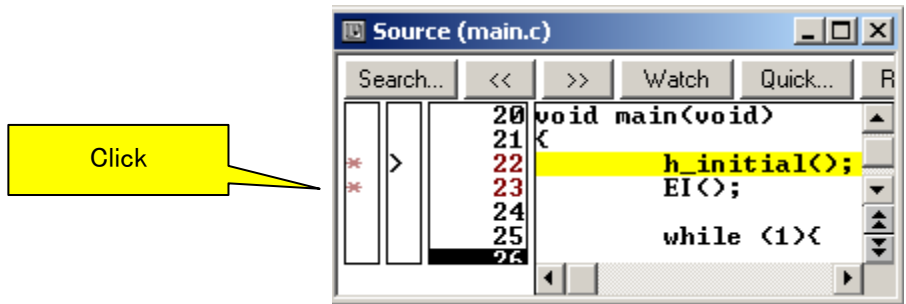

### 5.3.4 Display global variables

With using Watch Window, you can display global variables. There are several ways to register global variables to watch window. In this section, how to register from source window is described.

- ① Right-click the variable on source window, then select "Add Watch..."

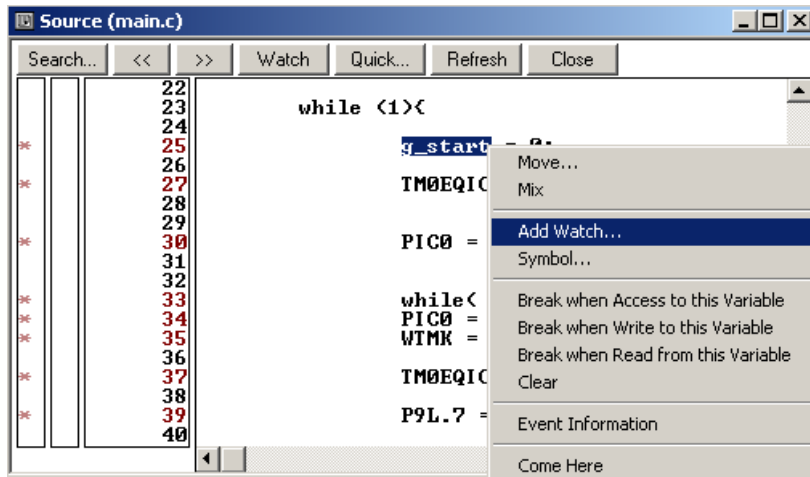

- ② Add Watch dialog opens. Click **OK**.

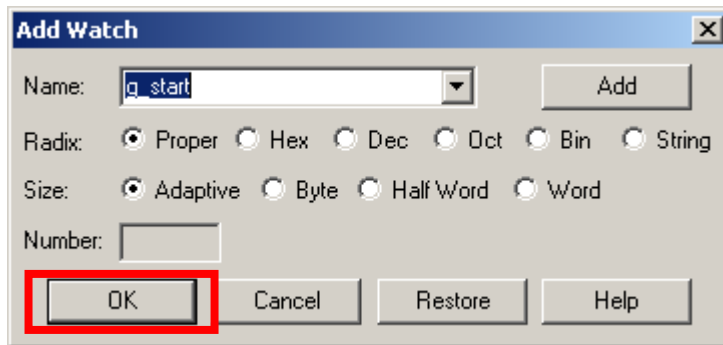

- ③ Adding a variable to watch window is completed.



### 5.3.5 Display global variables (internal RAM) while programs are running

RAM, general-purpose register, and SFR can be referred by the pseudo real-time monitor function even when the programs are running.

Select "Option" menu -> "Extended Option...". Follow below settings.

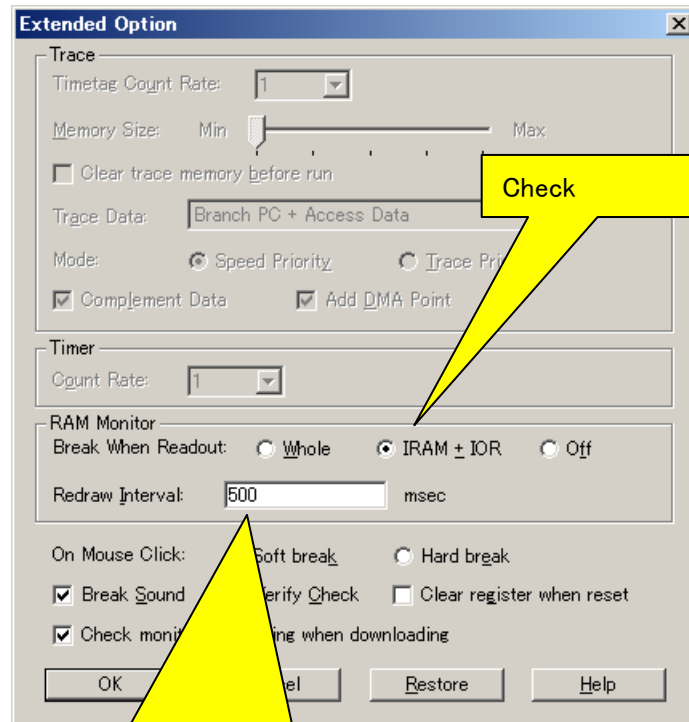

Specify the sampling time (ms) of the real-time monitor function (default: 500ms). The sampling time can be specified in 100-ms units from 100 to 65500. It will not monitor if it is set to "0" or blank.

**Note:**

- The user program momentarily breaks upon a read.
- Do not use the pseudo real-time monitor function while using the memory window. It uses the system resources significantly as it monitors the displaying memory as well.
- It is recommended to close the memory window when you use the pseudo real-time monitor function.

### 5.3.6 Display local variables

Local variable window is used to display local variables.

By clicking the button below, you can open the local variable window.

Unlike global variables, local variables cannot be displayed when programs are running.

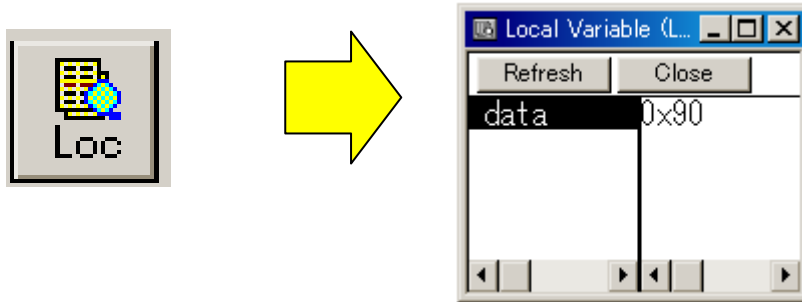

### 5.3.7 Display memory and SFR contents

By clicking the button below, you can open the memory window.

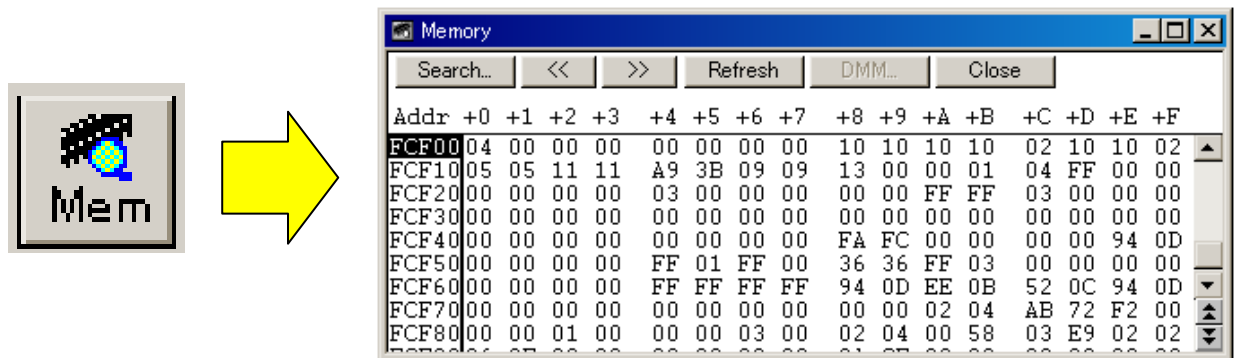

By clicking the button below, you can open the IOR window.

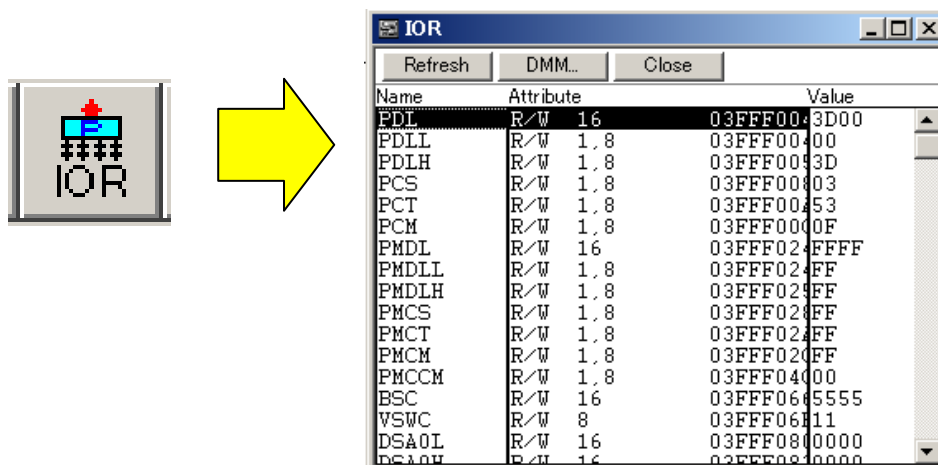

## 5.4 WriteEZ5

Since the program downloaded by ID850QB includes monitoring files for debugging, it cannot run stand-alone. However, if you use WriteEZ5 to write programs, it does not write monitoring files. Therefore, it can run stand-alone.

Also, if you forgot the security ID or if you set On-Chip Debug Option Byte to disable the on-chip debug function, you cannot start debugger. In this case, you need to delete the setting values of security ID and On-Chip Debug Option Byte. Use WriteEZ5 to erase the flash memory.

WriteEZ5 is installed at "1.2.2 Installation of Development Tools".

Start WriteEZ5 by selecting "Windows Start" menu, "Programs", "NEC Electronics Tools", "WriteEZ5", "V1.00", and "WriteEZ5".

The hardware for WriteEZ5 is incorporated in TK-850/JH3E+NET.

- ① The switch of TK-850/JH3E+NET is set as follows, and connects TK-850/JH3E+NET to PC.

SW1

|      |     |
|------|-----|
| Bit1 | OFF |
| Bit2 | ON  |
| Bit3 | ON  |
| Bit4 | ON  |

- ② Please execute WriteEZ5.

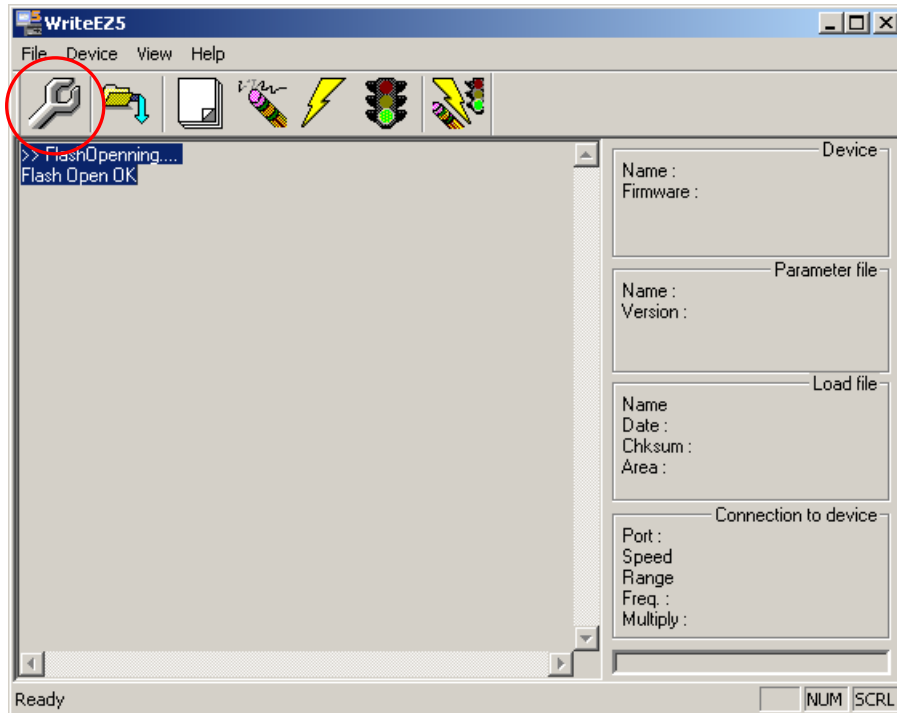

- ③ Push the 「Setup」 button.



- ④ Push the 「PRM File Read」 button.

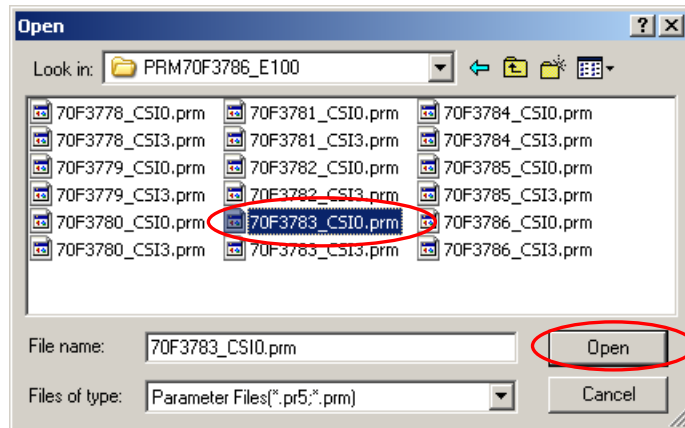

- ⑤ Please select “70F3783\_CSI0.prm” in the directory of “¥PRM¥PRM70F3786\_E100” in the CD-ROM.

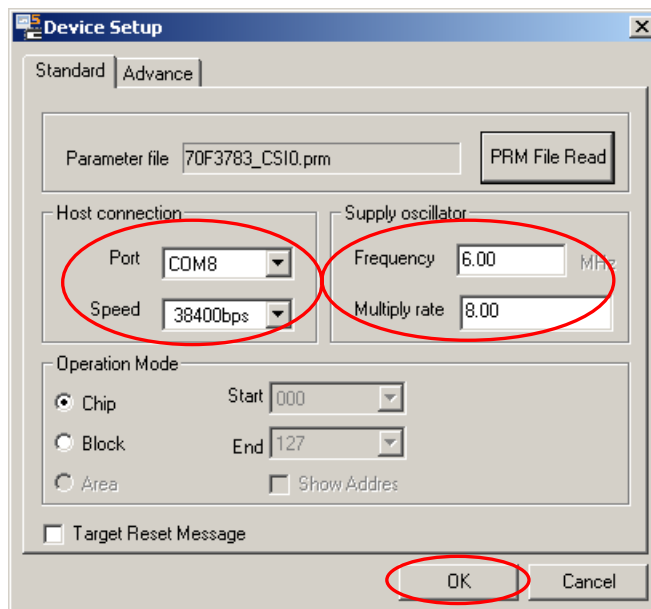

- ⑥ "Port" selects the COM port number where TK-850/JH3E+NET is allocated.  
※Only the COM port number that the personal computer has is displayed in this pull-down menu.  
Input “6.00” to “Frequency”  
Input “8.00” to “Multiply rate”  
Input “38400” to “Speed”, and click “OK”

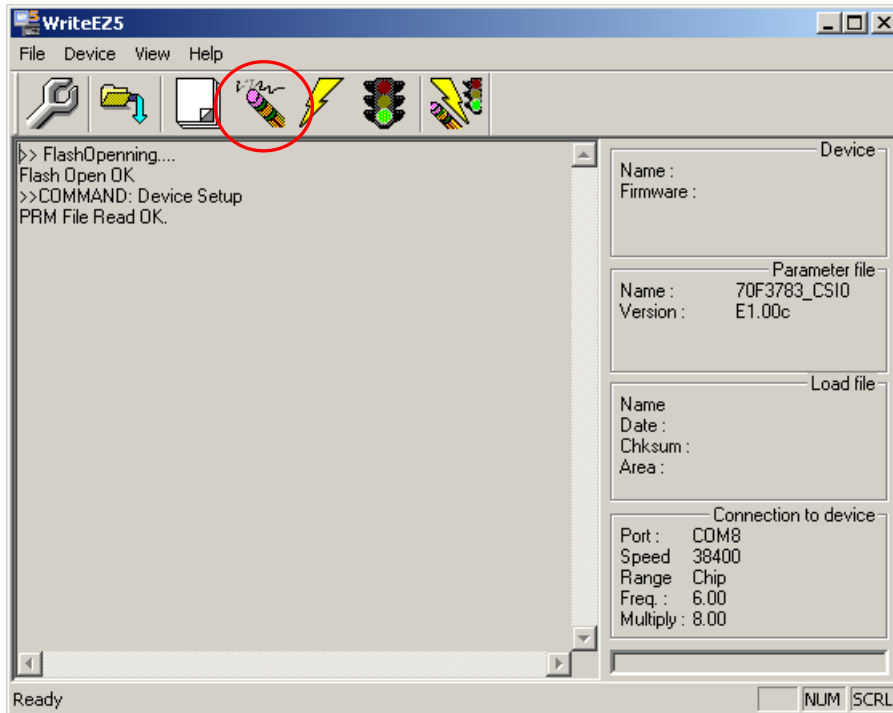

⑦ "Erase" The deletion of the flash memory begins when the button is pushed.

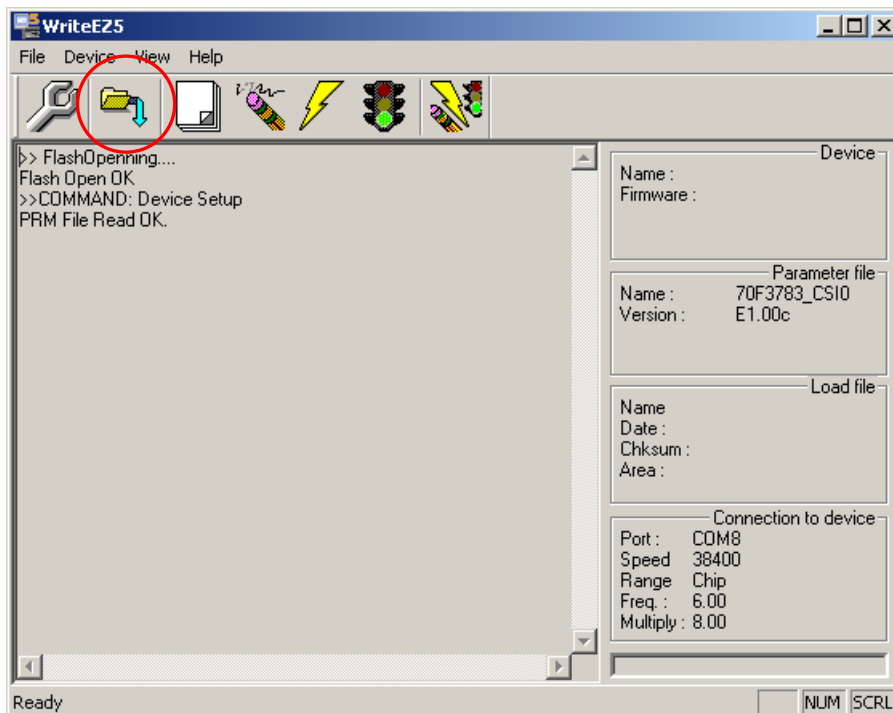

⑧ When you write the program, click "load" then select writing HEX file.

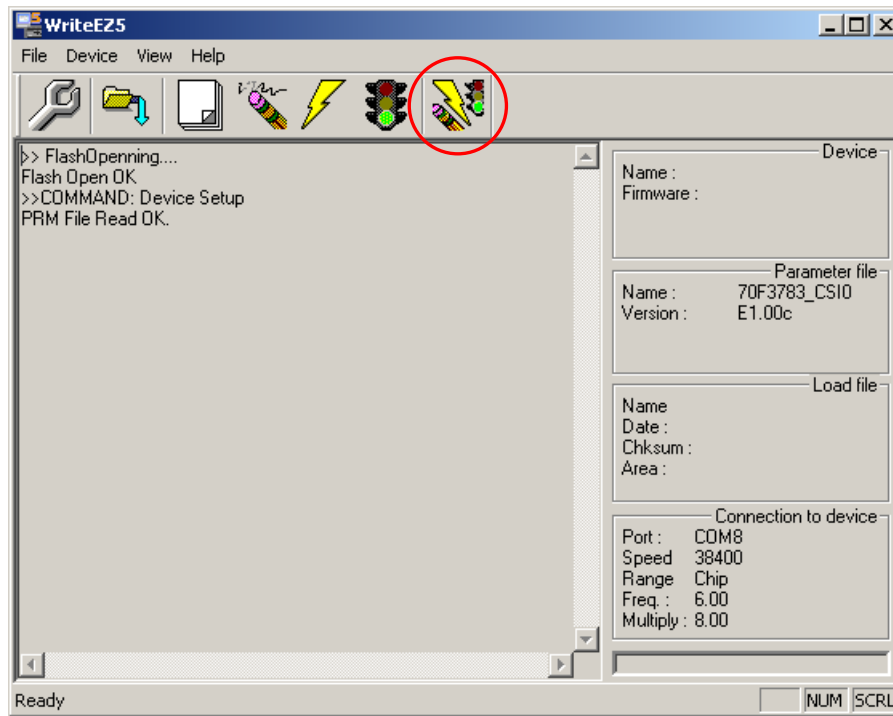

- ⑨ Hex file writing will be start by clicking “AutoProcedure” .

## 5.5 Parts list, Circuit diagram

From following page, it shows the parts list and the circuit diagram of the kit.

| No. | Mount Quantity | Mount Parts Reference                                                                             | Un-mount Parts Reference                                                                                                         | Type                      | Parts No                 | Maker  | Note              |
|-----|----------------|---------------------------------------------------------------------------------------------------|----------------------------------------------------------------------------------------------------------------------------------|---------------------------|--------------------------|--------|-------------------|
| 1   | 1              | FLMD0                                                                                             | DCVDD1,DCVDD2,P41,P42,<br>P76,P77,P78,P79,P90,P91,<br>P92,P93,P94,P95,P96,P97,<br>P98,P912,UVDD,T_RESET,<br>RXD,CTXD,CRXD,AVREF0 | Solder short pad          | SS                       |        | FLMD0 -><br>short |
| 2   | 0              |                                                                                                   | FLMD0,CANS                                                                                                                       | Solder short pad          | SO                       |        |                   |
| 3   | 0              |                                                                                                   | CAN1                                                                                                                             | D-SUB Connector           | JHEY-9S-1A3B             | JST    | Not mounted       |
| 4   | 0              |                                                                                                   | CN1                                                                                                                              | Connector                 | FX8C-100P-SV             | HIROSE | Not mounted       |
| 5   | 1              | CN4                                                                                               |                                                                                                                                  | Connector                 | HEC0470-01-630           |        |                   |
| 6   | 0              |                                                                                                   | CN5                                                                                                                              | Connector                 | DF17(3.0)-030DS-0.5V(57) | HIROSE | Not mounted       |
| 7   | 23             | C1,C2,C3,C4,C5,C6,C9,C11,<br>C15,C17,C18,C19,C23,C24,<br>C25,C27,C28,C33,<br>C34,C35,C36,C37,C38, | C45<br>C50                                                                                                                       | Chip ceramic cap          | 0.1uF                    |        |                   |
| 7   | 3              | C26,C30,C46                                                                                       | C49                                                                                                                              | Chip ceramic cap          | 0.1uF                    |        |                   |
| 8   | 2              | C7,C8                                                                                             |                                                                                                                                  | Chip ceramic cap          | 40PF                     |        |                   |
| 9   | 3              | C12,C10,C39                                                                                       |                                                                                                                                  | Chip ceramic cap          | 4.7uF(2125)              |        |                   |
| 10  | 6              | C13,C14,C40,C41,C42,C43                                                                           |                                                                                                                                  | Chip ceramic cap          | 10pF                     |        |                   |
| 11  | 2              | C21,C16                                                                                           |                                                                                                                                  | Aluminum Electrolytic Cap | 4.7uF/25V                |        |                   |
| 12  | 3              | C20,C22,C29                                                                                       |                                                                                                                                  | Chip ceramic cap          | 0.47uF                   |        |                   |
| 13  | 2              | C32,C31                                                                                           |                                                                                                                                  | Aluminum Electrolytic Cap | 10uF/25V                 |        |                   |
| 14  | 1              | C44                                                                                               |                                                                                                                                  | Chip ceramic cap          | 0.022uF/50V              |        |                   |
| 15  | 2              | C48,C47                                                                                           |                                                                                                                                  | Chip ceramic cap          | 30PF                     |        |                   |
| 16  | 1              | D1                                                                                                |                                                                                                                                  | Diode                     | NSAD500F                 | NECEL  |                   |
| 17  | 0              |                                                                                                   | D2,D3,D4                                                                                                                         | Diode                     | RD27S                    | NECEL  | Not mounted       |
| 18  | 0              |                                                                                                   | FP1                                                                                                                              | Connector                 | FFC-16BMPE1              | HONDA  | Not mounted       |
| 19  | 1              | JP1                                                                                               |                                                                                                                                  | Connector                 | FFC-6BMPE1               | HONDA  |                   |
| 20  | 0              |                                                                                                   | JP2                                                                                                                              | Connector                 | FFC-4BMPE1               | HONDA  | Not mounted       |
| 21  | 0              |                                                                                                   | J1                                                                                                                               | Connector                 | FFC-2AMEP1               | HONDA  | Not mounted       |
| 22  | 3              | LED1,LED2,LED3                                                                                    |                                                                                                                                  | LED                       | PG1112H                  | ROHM   |                   |
| 23  | 2              | L2,L1                                                                                             |                                                                                                                                  | ferrite beads             | BLM41PG750S              | Murata |                   |
| 24  | 3              | L3,L4,L5                                                                                          |                                                                                                                                  | ferrite beads             | BLM18PG600SN1            | Murata |                   |
| 25  | 0              |                                                                                                   | L6                                                                                                                               | Common mode filter        | ACT45B-510-2P            | TDK    | Not mounted       |
| 26  | 1              | MR1                                                                                               |                                                                                                                                  | resister module           | CN1J8T 102J              | KOA    |                   |
| 27  | 2              | MR3,MR2                                                                                           |                                                                                                                                  | resister module           | CN1E4K-105J              | KOA    |                   |
| 28  | 1              | NWIRE1                                                                                            |                                                                                                                                  | Connector                 | 8830E-026-170S           | KEL    |                   |
| 29  | 8              | R1,R20,R21,R22,R27,R31,<br>R34,R43                                                                |                                                                                                                                  | Chip resister             | 1.5K                     |        |                   |
| 30  | 18             | R2,R3,R4,R5,R6,R7,R8,R9,<br>R11,R12,R14,R15,R16,R17,<br>R24,R25,R30,R44                           | R55,R62                                                                                                                          | Chip resister             | 10K                      |        |                   |
| 31  | 12             | R10,R13,R45,R46,R47,R48,<br>R49,R50,R51,R52,R53,R54                                               |                                                                                                                                  | Chip resister             | 100                      |        |                   |
| 32  | 4              | R18,R19,R23,R26                                                                                   |                                                                                                                                  | Chip resister             | 100K                     |        |                   |
| 33  | 2              | R28,R29                                                                                           |                                                                                                                                  | Chip resister             | 27                       |        |                   |
| 33  | 2              | R35,R36                                                                                           |                                                                                                                                  | Chip resister             | 30                       |        |                   |
| 34  | 3              | R32,R33,R57                                                                                       |                                                                                                                                  | Chip resister             | 1M                       |        |                   |
| 35  | 3              | R37,R58,R59                                                                                       |                                                                                                                                  | Chip resister             | 270                      |        |                   |
| 36  | 4              | R38,R39,R40,R41                                                                                   |                                                                                                                                  | Chip resister             | 49.9(1%)                 |        |                   |
| 37  | 1              | R42                                                                                               |                                                                                                                                  | Chip resister             | 10(1%, 0.1W)             |        |                   |
| 38  | 1              | R56                                                                                               |                                                                                                                                  | Chip resister             | 12.4K(1%, 0.1W)          |        |                   |
| 39  | 0              |                                                                                                   | R60,R61                                                                                                                          | Chip resister             | 120                      |        | Not mounted       |
| 40  | 0              |                                                                                                   | R63,R64,R66                                                                                                                      | Chip resister             | xxx                      |        | Not mounted       |
| 41  | 1              | R67                                                                                               | R65                                                                                                                              | Chip resister             | 0                        |        | Not mounted       |
| 42  | 1              | SW1                                                                                               |                                                                                                                                  | Switch                    | CHS-08B                  | COPAL  |                   |

TK-850/JH3E+NET User's Manual

|    |   |             |                                              |                |                          |         |             |
|----|---|-------------|----------------------------------------------|----------------|--------------------------|---------|-------------|
| 43 | 3 | SW2,SW3,SW4 |                                              |                | SKQMBB                   | ALPS    |             |
| 44 | 0 |             | TPU1,TPU2,TPU3,TPU4,TPU5,TPU6,TPU7,TPU8,TPU9 | Check terminal | TPU                      |         | Not mounted |
| 45 | 0 |             | TP1,TP2,TP3,TP4,TP5,TP6,TP7                  | Check pin      | LC-2                     | MAC8    | Not mounted |
| 46 | 1 | TR1         |                                              | Connecter      | TLA-6T718                | TDK     |             |
| 47 | 2 | USB2,USB1   |                                              | Connecter      | UX60A-MB-5ST             | HIROSE  |             |
| 48 | 1 | U1          |                                              | IC             | S-80129ANMC-JCOxG        | SII     |             |
| 49 | 1 | U2          |                                              | IC             | V850ES/JH3-E             | NECEL   |             |
| 50 | 1 | U3          |                                              | 7segLED        | LA-301MB                 | ROHM    |             |
| 51 | 1 | U4          |                                              | IC             | SN74LVC2G125DCU          | TI      |             |
| 52 | 1 | U5          |                                              | IC             | SN74LVC3G07DCT           | TI      |             |
| 53 | 1 | U6          |                                              | IC             | UPD78F0730MC             | NECEL   |             |
| 54 | 2 | U9,U7       |                                              | IC             | SN74LVC1G125DCK          | TI      |             |
| 55 | 1 | U8          |                                              | IC             | SN74LVC1G132DCK          | TI      |             |
| 56 | 1 | U10         |                                              | IC             | LM1117MPX-3.3            | NS      |             |
| 57 | 1 | U11         |                                              | IC             | LAN8700C                 | SMSC    |             |
| 58 | 0 |             | U12                                          | IC             | TJA1050T                 | NXP     | Not mounted |
| 59 | 1 | Y1          |                                              | Resonator      | HCM49-6.000MABJ-UT       | Citizen |             |
| 60 | 1 | Y2          |                                              | Resonator      | MC-306 32.7680K-A0       | EPSON   |             |
| 61 | 1 | Y3          |                                              | Resonator      | CSTCE16M0V53-R0          | Murata  |             |
| 62 | 1 | Y4          |                                              | Resonator      | ABM3B-25.000MHZ-10-1-U-T | ABRACON |             |
| 63 | 1 | JP1         | JP2                                          | Short pin      | HIF3GA-2.54SP            | HIROSE  |             |

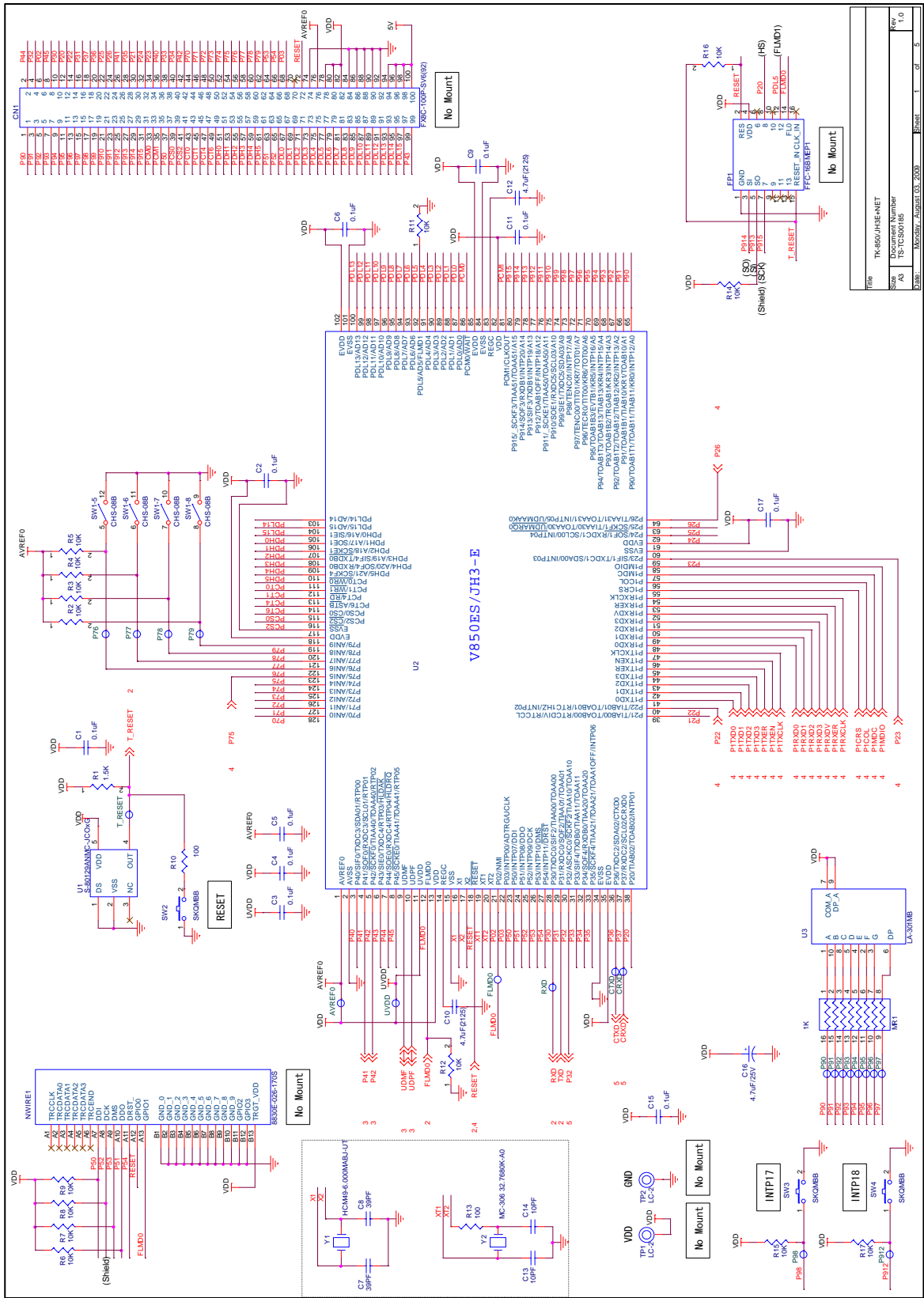

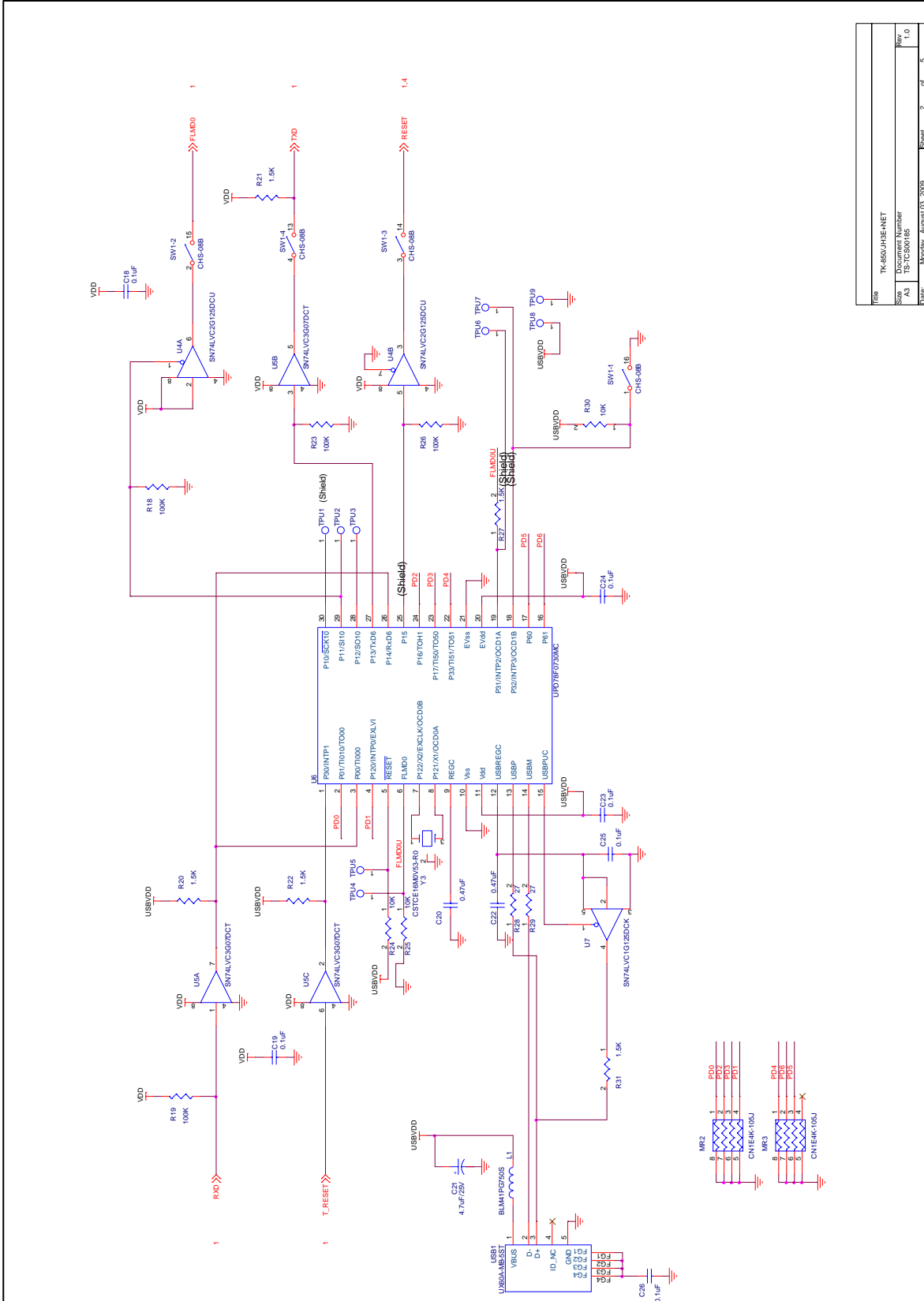

|       |                              |
|-------|------------------------------|
| Title | TK-850/JH3E+NET              |
| Size  | Document Number<br>TK-850-10 |
| Date  | Monday, August 03, 2009      |
| Sheet | 2 of 5                       |

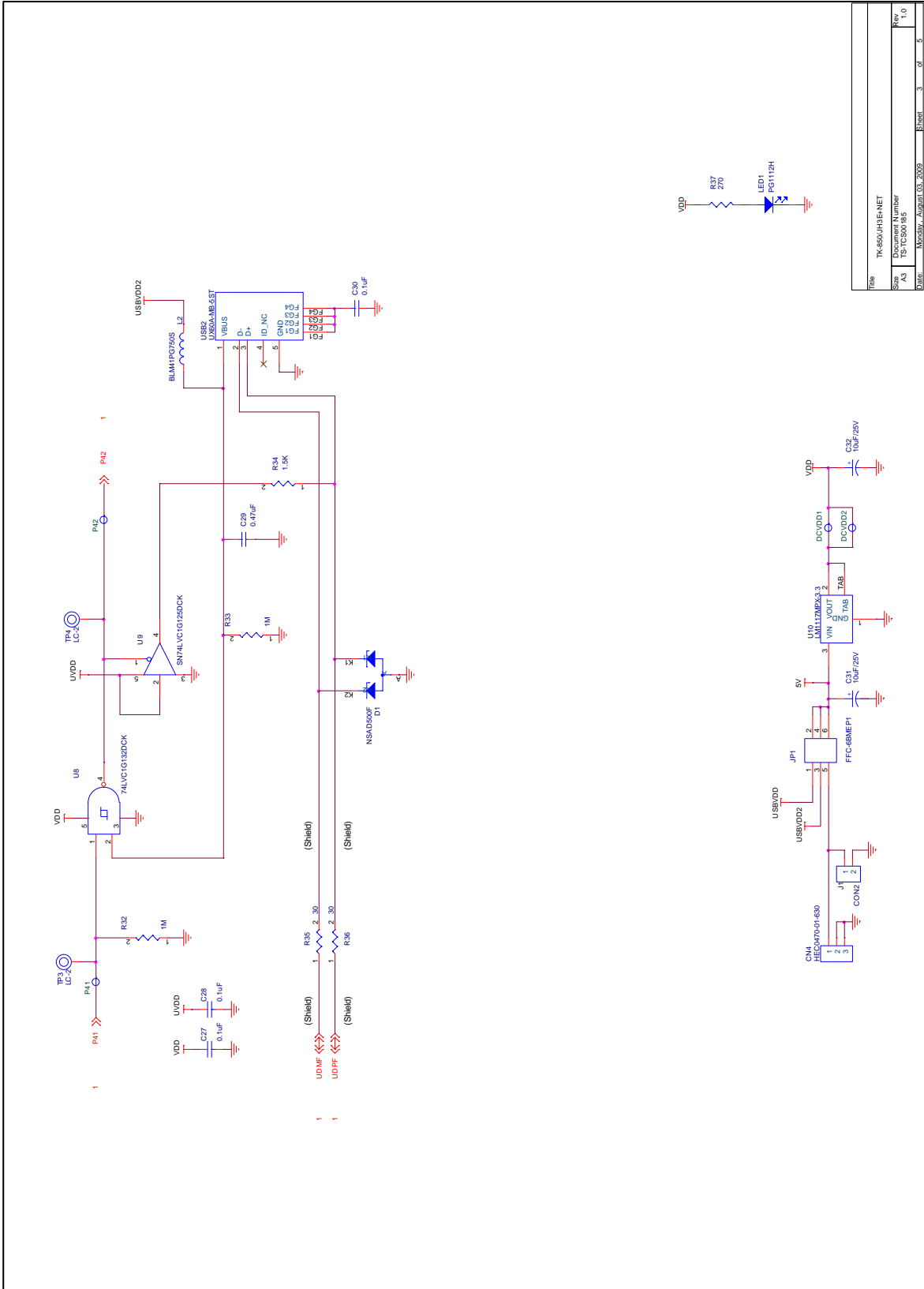

|      |                     |
|------|---------------------|
| File | TK-850/JH3E+NET     |
| Rev  | Revised Number      |
|      | A3 TS-TS000185      |
| Date | MS05W_Suppl.03_2009 |
|      | Sheet 3 of 5        |
|      | Rev 1.0             |

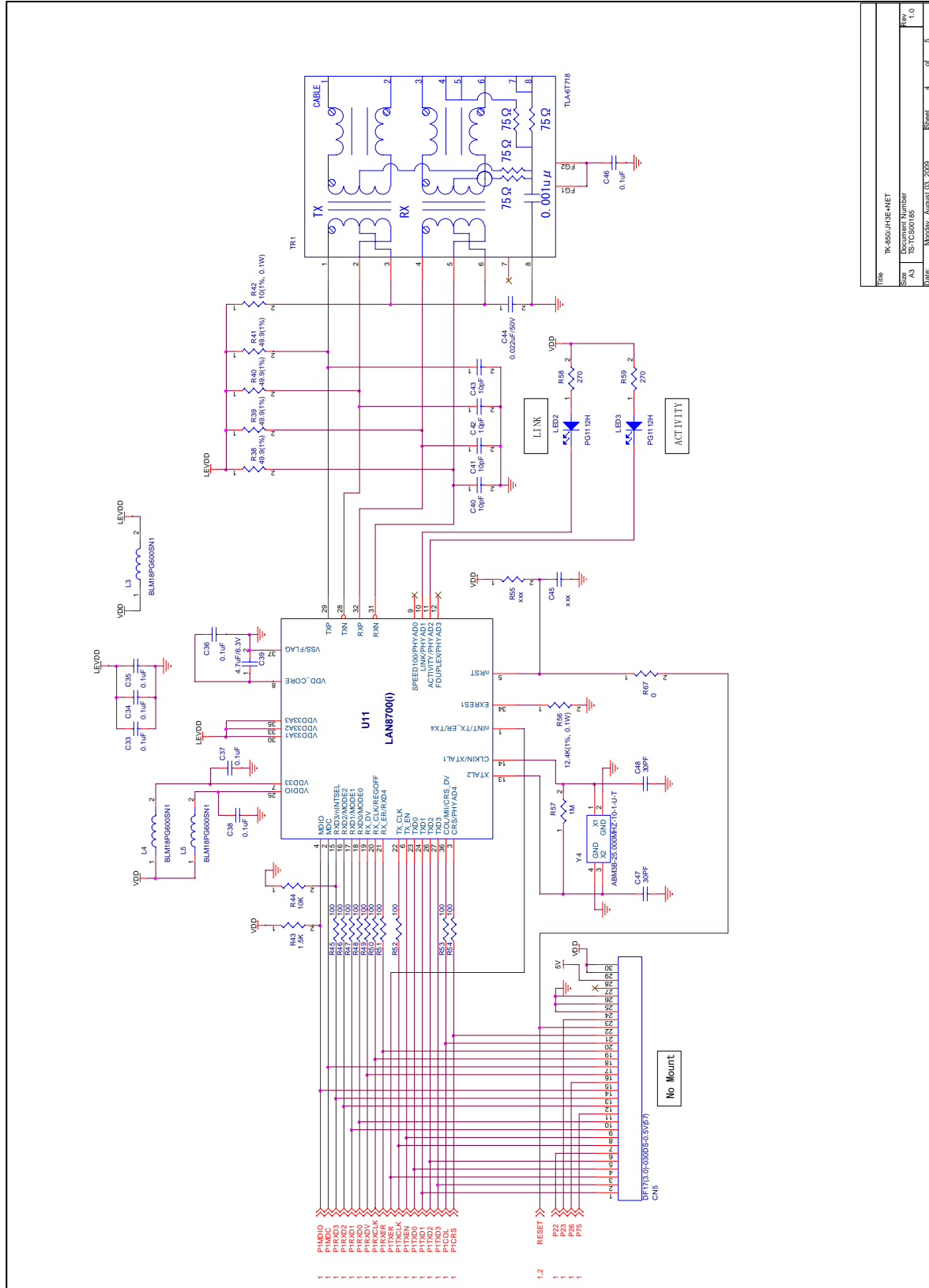

|       |                               |
|-------|-------------------------------|
| Title | TK-850/JH3E-NET               |
| Size  | Document Number<br>TK-PC00165 |
| Date  | Monday, August 05, 2009       |
| Sheet | 4 of 5                        |
| Rev   | 1.0                           |

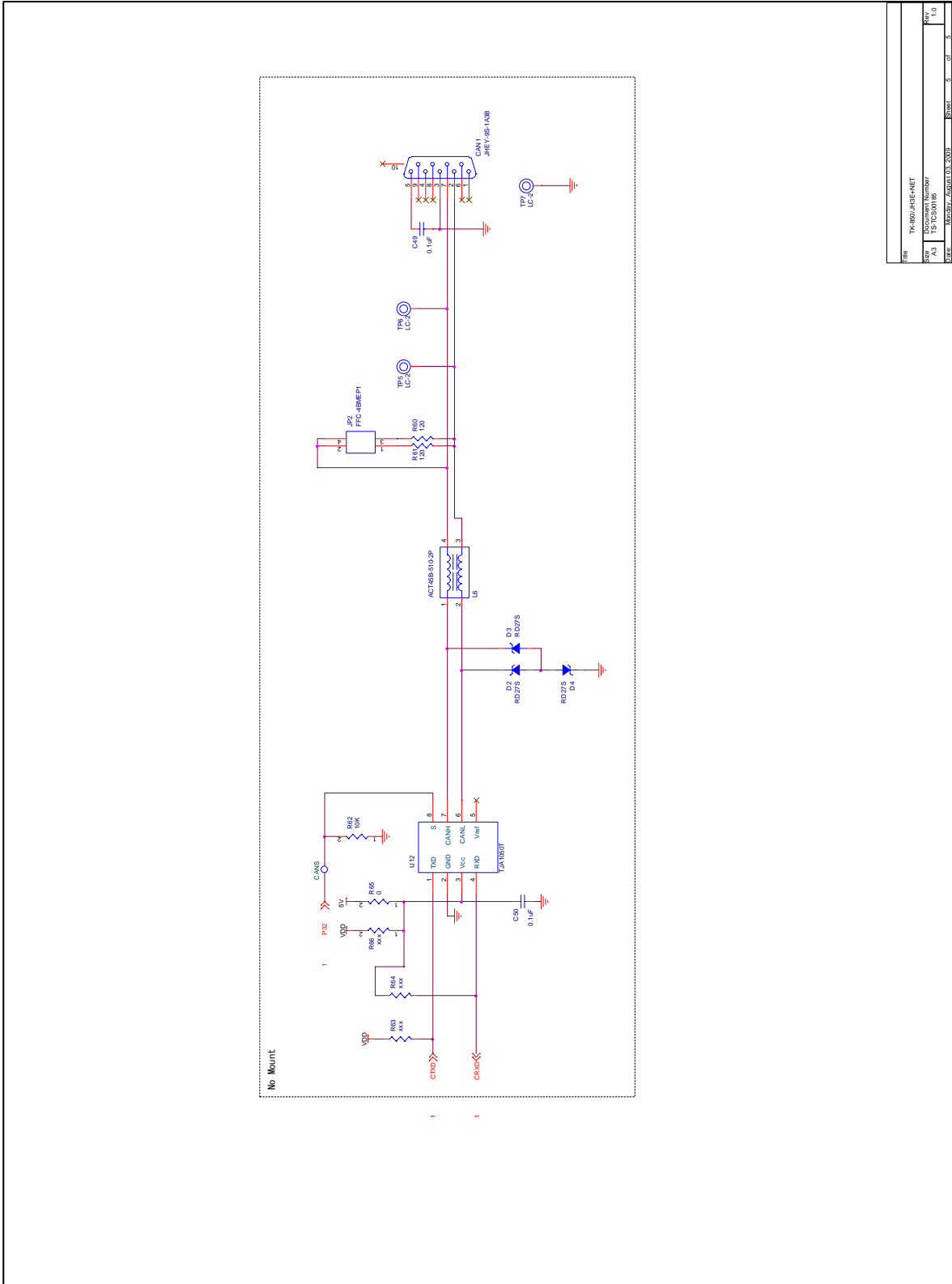

|       |                      |
|-------|----------------------|
| File  | TK-850/JH3E+NET      |
| Size  | Document Number      |
| A3    | TS-PC510185          |
| Page  | 1 of 5               |
| Rev   | 1.0                  |
| Model | Model: JH3E+NET_2009 |
| Sheet | 5 of 5               |