

# User's Manual

## TK-850/JH3U-SP

**Date published: November 2008**  
**Rev. 1.0**  
**© TESSERA TECHNOLOGY INC. 2008**  
**Printed in Japan**

Windows and Windows XP are registered trademarks or trademarks of Microsoft Corporation in the United States and/or other countries.

- The information is subject to change without notice.
- No part of this document may be copied or reproduced in any form or by any means without prior written consent of TESSERA TECHNOLOGY INC.. TESSERA TECHNOLOGY INC. assumes no responsibility for any errors that may appear in this document.
- TESSERA TECHNOLOGY INC. does not assume any liability for infringement of patents, copyrights or other intellectual property rights of third parties by or arising from the use of TESSERA TECHNOLOGY INC. products listed in this document or any other liability arising from the use of such products. No license, express, implied or otherwise, is granted under any patents, copyrights or other intellectual property rights of TESSERA TECHNOLOGY INC. or others.
- Descriptions of circuits, software and other related information in this document are provided for illustrative purposes in semiconductor product operation and application examples. The incorporation of these circuits, software and information in the design of a customer's equipment shall be done under the full responsibility of the customer. TESSERA TECHNOLOGY INC. assumes no responsibility for any losses incurred by customers or third parties arising from the use of these circuits, software and information.

#### CAUTION

- Do not give any physical damage to this equipment such as dropping
- Do not superimpose voltage to this equipment.
- Do not use this equipment with the temperature below 0°C or over 40°C.
- Make sure the USB cables are properly connected.
- Do not bend or stretch the USB cables.
- Keep this equipment away from water.
- Take extra care to electric shock.
- This equipment should be handled like a CMOS semiconductor device. The user must take all precautions to avoid build-up of static electricity while working with this equipment.
- All test and measurement tool including the workbench must be grounded.
- The user/operator must be grounded using the wrist strap.
- The connectors and/or device pins should not be touched with bare hands.

## Contents

CHAPTER 1 PREPARATION.....	8
1.1 Development Tools / Software.....	9
1.2 Installation of Development Tools .....	10
1.2.1 Installation Package .....	10
1.2.2 Installation of Development Tools.....	10
1.3 Sample Programs.....	15
1.3.1 Preparation of Sample Programs.....	15
1.3.2 Overview of Sample Programs .....	18
1.4 Installation of USB Driver .....	19
1.4.1 Installation on Windows XP .....	20
1.4.2 Installation on Windows 2000 .....	23
1.4.3 Completion of USB Driver Installation.....	26
CHAPTER 2 EXPERIENCES.....	27
2.1 Start PM+ .....	29
2.2 What is PM+.....	30
2.3 Load Workspace (project) .....	32
2.4 Set Options.....	34
2.4.1 "Extend" Tab.....	34
2.4.2 "Preprocessor" Tab .....	35
2.5 Create Load Module Files .....	36
2.6 Check Debugger Settings.....	38
2.7 Check Board Settings.....	40
2.8 Start Debugger (ID850QB).....	41
2.9 Run Programs.....	44
2.10 Stop Programs .....	47
2.11 Close Debugger (ID850QB) .....	48
2.12 Quit PM+.....	49
CHAPTER 3 HARDWARE SPECIFICATIONS .....	50
3.1 Connector Layout.....	51
3.2 Function Layout .....	52
3.3 Hardware Functions.....	53
3.3.1 SW1.....	53
3.3.2 SW2 (RESET SW).....	54
3.3.3 SW3 (INTP12) .....	54
3.3.4 SW4 (INTP13) .....	54
3.3.5 LED1.....	55
3.3.6 LED2 (POWER) .....	55
3.3.7 U20 (for no LCD version) .....	55
3.3.8 JP1 .....	56

3.3.9 JP2 .....	56
3.3.10 CN1 .....	56
3.3.11 CN2 .....	56
3.3.12 CN4 .....	56
3.3.13 CN7 .....	56
3.3.14 CN8 .....	57
3.3.15 CN9 .....	57
3.3.16 J1 .....	57
3.3.17 NWIRE1 Connector .....	57
3.3.18 USB1 Connector .....	57
3.3.19 USB2 Connector .....	57
3.3.20 USB3 Connector .....	57
3.3.21 DSUB1 Connector .....	58
3.3.22 U24 (IrDA Infrared communication module) .....	58
3.3.23 VR1 .....	58
3.4 solder-short pad label .....	59
3.5 Explanation of unit .....	60
3.5.1 USB function .....	60
3.5.2 USB Host .....	61
3.5.3 IrDA infrared communication .....	62
3.5.4 Ethernet .....	63
3.5.5 Touch panel LCD (LCD version only) .....	64
3.5.6 SRAM .....	65
3.5.7 External bus interface .....	66
1.1. External bus I/F devices .....	66
1.2. Address mapping .....	66
1.3. External memory address area .....	66
3.5.8 External connector .....	67
3.5.9 Audio input .....	69
3.5.10 Audio output .....	70
3.5.11 RS-232C .....	71
CHAPTER 4 TROUBLESHOOTING .....	72
4.1 If you cannot find USB driver when you connect PC to the kit .....	72
4.2 Error when you start the debugger .....	72
4.2.1 "Can not communicate with Emulator..." (F0100 or A0109) .....	72
4.2.2 "Incorrect ID Code." (Ff603) .....	73
4.3 Monitor memory cannot be accessed. (F0c72) .....	73
CHAPTER 5 OTHER INFORMATION .....	74
5.1 Create a new workspace .....	75
5.2 Register additional source file .....	83
5.3 Debugger tips .....	85

- 5.3.1 Change display of buttons ..... 85
- 5.3.2 Display source list and function list ..... 85
- 5.3.3 Set/delete breakpoints..... 86
- 5.3.4 Display global variables..... 87
- 5.3.5 Display local variables..... 88
- 5.3.6 Display memory and SFR contents ..... 88
- 5.4 WriteEZ1 ..... 89
- 5.5 Circuit diagram..... 94

# Introduction

TK-850/JH3U-SP is the evaluation kit for development using "V850ES/JH3-U", NEC Electronics 32bit all flash microcontroller.

The user only needs to install the development tools and USB driver, and connect the host machine with the target board to start the code development, build, monitoring the output, and debugging code.

(This demonstration kit uses the on-chip debug feature from the microcontroller itself, without emulator connection)

## Configuration for Debugging

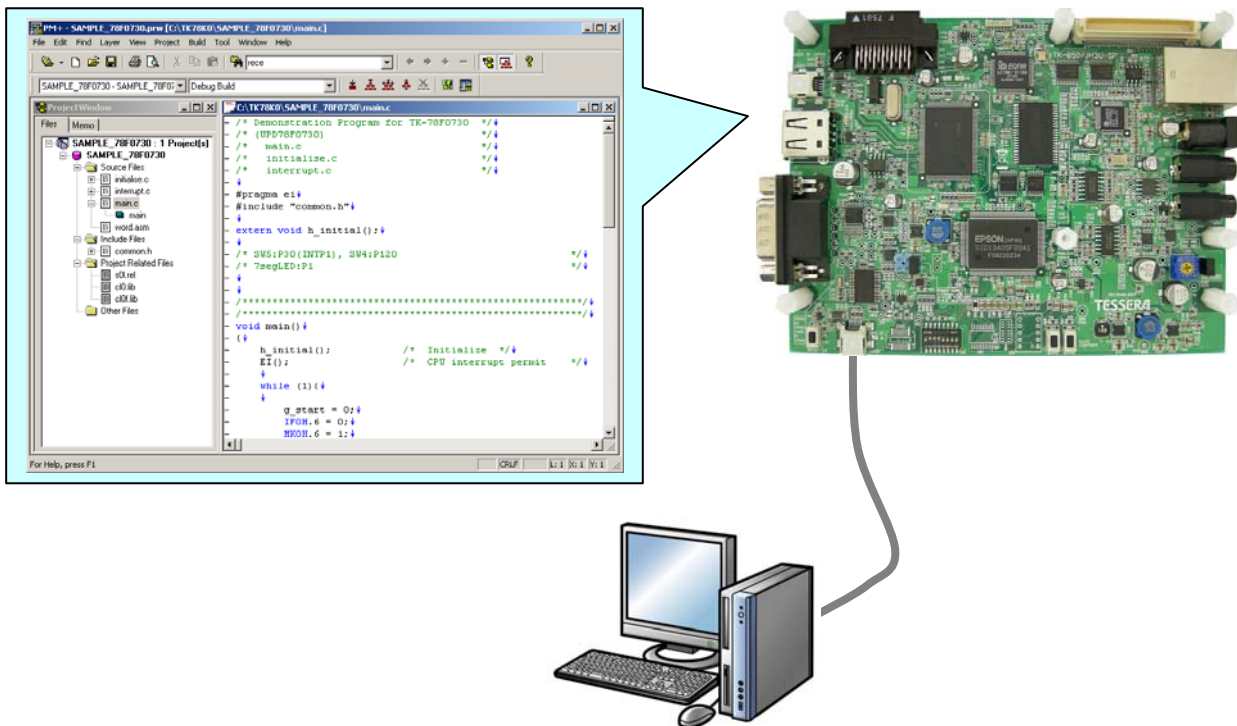

- Overview** This manual consists of the following contents.
- Read chapter 1 and 2 first for installing the development tools and using the sample programs.
  - Read chapter 3-5 for customizing the sample programs and the hardware.
- Chapter 1: Preparations**  
Install the development tools
- Chapter 2: Experiences**  
Experience the basic operations of integrated development environment (PM+) and integrated debugger (ID850QB) with using sample programs.
- Chapter 3: Hardware Specifications**  
Explain the hardware of TK-850/JH3U-SP
- Chapter 4: Troubleshooting**  
Describe how to solve troubles you may face, such as errors when starting the integrated debugger (ID850QB)
- Chapter 5: Other Information**  
Introduce other information, such as how to create a new workspace (project) on integrated development environment (PM+), how to register additional source file, and some useful tips of the integrated debugger. The circuit diagrams of demonstration kit are included in this chapter.
- Reader** This manual is intended for development engineers who wish to become familiar with the development tools for the V850.
- It is assumed that the readers have been familiar with basics of microcontrollers, C and Assembler languages, and the Windows™ operating system.
- Purpose** This manual is intended to give users an understanding of the features, hardware configurations, development tools for the V850.

# CHAPTER 1 Preparation

This chapter describes following topics:

- Overview and installation of development tools
- Installation of development tools
- Overview and preparation of sample programs

Users can experience the development flow such as coding, build, debugging, and test, by using the development tools bundled with TK-850/JH3U-SP.

## 1.1 Development Tools / Software

- **Device file DF703771 V1.00**

A device file contains device specific information. So, users need a device file to use the development tools.
- **Integrated Development Environment (IDE) PM+ V6.31**

The IDE works on Windows operation system.  
Users can develop a system efficiently by using the editor with idea processor function, compiler, and debugger.
- **C Compiler CA850 W3.20 (code size limited version)**

C compiler for the V850 microcontrollers. The object code size is limited to 128 Kbyte.  
This compiles C code for V850 and ANSI-C code program into assembler code.  
This produces object code and linker.
- **V850 Integrated Debugger ID850QB V3.50**

This is the tool for debugging the object program generated by C compiler and assembler. The debugger enables to do C source level debugging. With the debugger, you can debug the code easily and efficiently by referring and changing variables, using step-in debugging function, and so on.
- **Built-in Flash Memory Writing Program WriteEZ1**

This is the Windows software to write programs on built-in flash memory.  
By connecting TK-850/JH3U-SP and PC with bundled USB cable, you can write/delete programs on the built-in flash memory.
- **Sample program**

The explanation uses Mass storage class (MSC) sample program in user's manual.

## 1.2 Installation of Development Tools

### 1.2.1 Installation Package

The attached CD-ROM includes the development tools and documentations. Users can use the installer to install those development tools and documentations.

### 1.2.2 Installation of Development Tools

- ① Please insert the CD-ROM in the drive. The installer will show up automatically. If it does not start automatically, please initiate it by double clicking the SETUP.EXE.

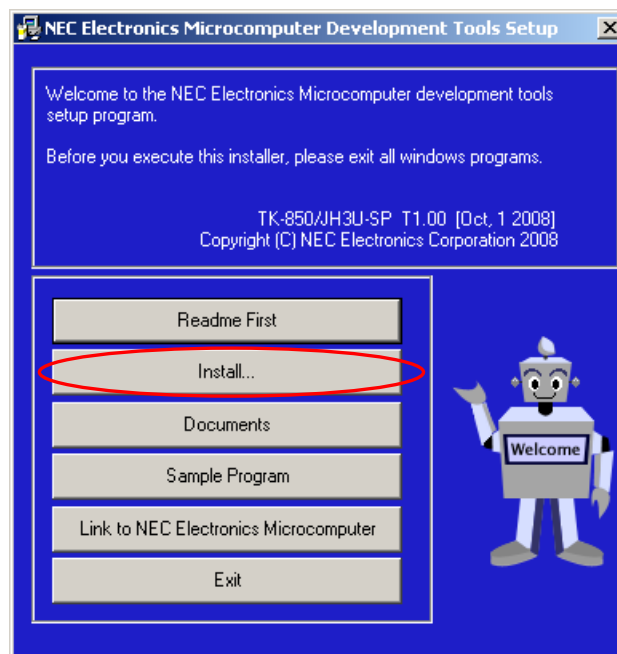

<1> Readme First

The contents of the CD-ROM, and some notes are available.  
Please read it at first.

<2> Install...

Click "Install" to start installation of development tools.  
For details, please refer to the next section.

<3> Documents

Manuals of development tools and the evaluation kit are available in PDF files.

When this button is clicked, the WWW browser will start. Adobe® Acrobat® Reader is available in the CD-ROM.

<4> Sample Program

Click this button to start the WWW browser for the sample program and the tutorial.

<5> Link to NEC Electronics Microcontrollers

Click this button to start the WWW browser display the link to the NEC Electronics Microcontroller web site ([http://www.necel.com/micro/index\\_e.html](http://www.necel.com/micro/index_e.html))

The NEC Electronics Microcontroller web page provides with the latest product/tool information and FAQs.

<6> Exit

Terminate the setup.

② Click the "Install"

③ "Tool Installer" dialog box is opened.

Select products that you need to install.

(as default, all the products that you need to use the TK-850/JH3U-SP are selected.)

"Explain" area displays an explanation of the selected product.

To change the installation destination, click **Browse...** .

When all the settings are completed, click **Install...** .

\* In this document, it is assumed that users install the programs under "NEC Electronics Tools" directory (default installation directory). Users can find the tools by selecting "Start Menu" -> "Programs" -> "NEC Electronics Tools".

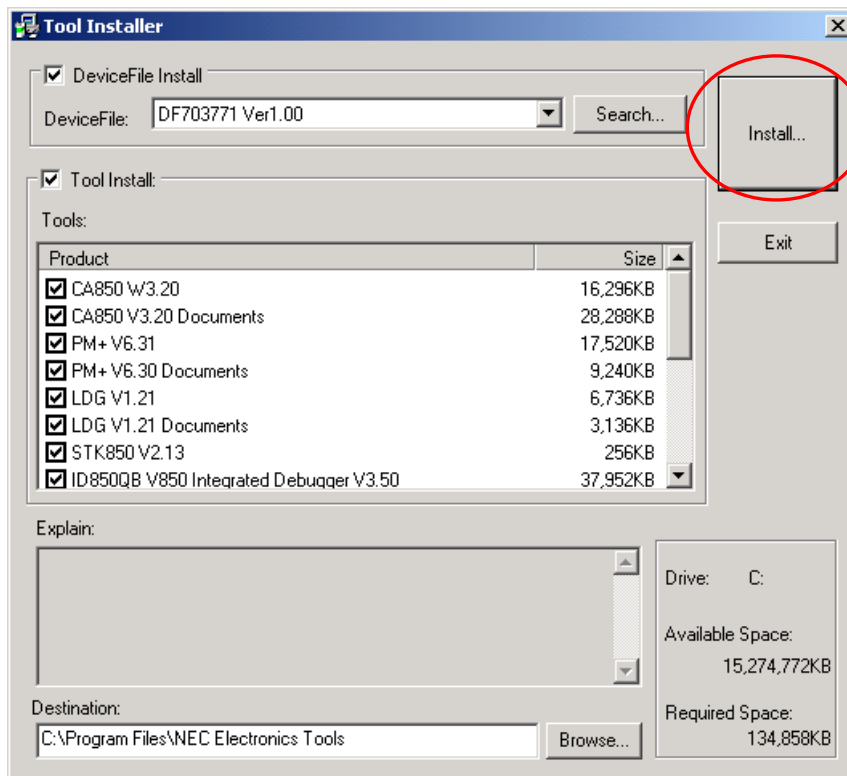

④ Click **OK** when "Install" confirmation dialog box is opened.

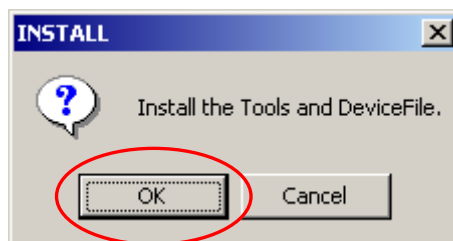

- ⑤ Read "software license agreement" and click **Yes** for continuing the installation.  
To stop the installation, click **No**.

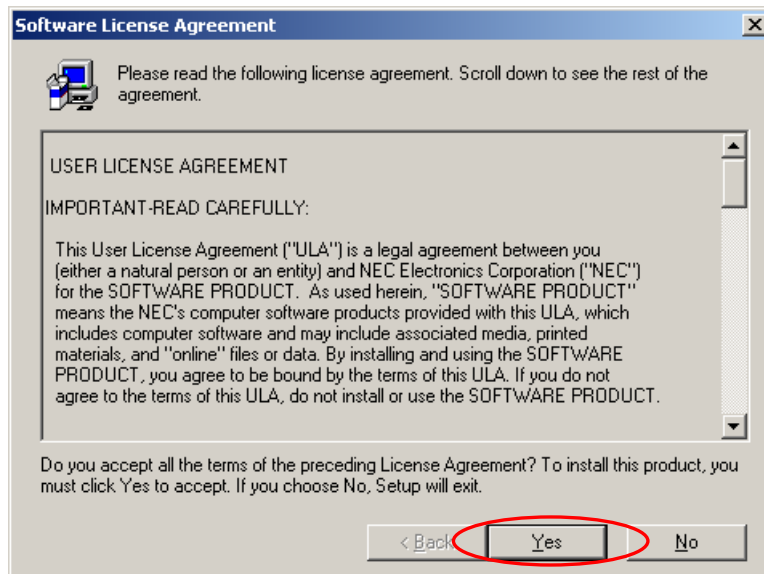

- ⑥ Enter the product ID, and click **Next**.
- \* The product ID is available on the other sheet.

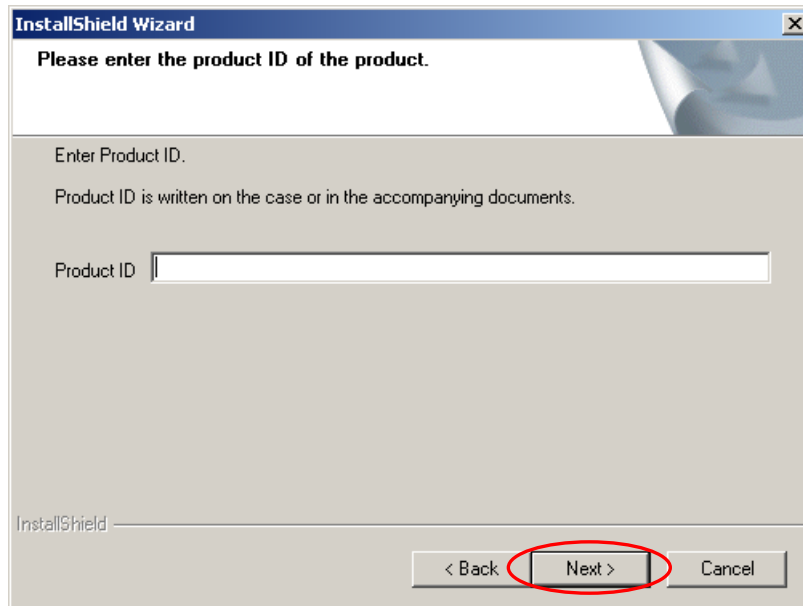

- ⑦ It starts copying the files.

- ⑧ If the “install Wizard :Kind of File” dialog displayed, Select ”Device File For V850ES/JH3-U”.  
Click **OK** .

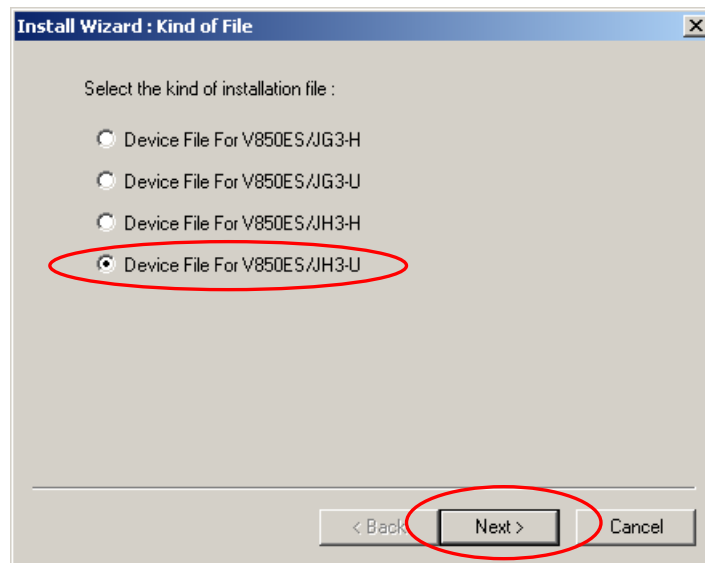

- ⑨ When the installation is completed, the following dialog opens.  
Click **OK** .

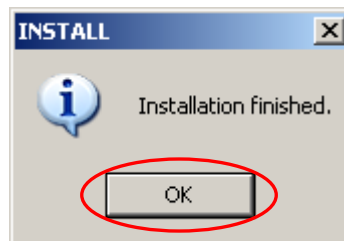

**Notes on the installation authority**

To install this tool in Windows 2000 or XP, the authority of an administrator is necessary. Therefore, please login as an administrator.

**Notes on the install-directory**

Please do not use 2-byte characters, such as umlaut in the directory name, where the product is to be installed.

**Note on the version of Windows**

If the language of the Windows is not English, a file transfer error during installation might be observed. In this case, please abort the installation in the language, and re-install it in an English version of Windows.

The identical problem may be observed, if a language other than English is specified as the system language in the “Regional Settings Properties” tab.

**Limitation**

Assembler RA850 and C compiler CA850 limit the object size to 128Kbyte.

## 1.3 Sample Programs

This section explains the overview and preparation of sample programs.

### 1.3.1 Preparation of Sample Programs

- ① Insert the CD-ROM disk in the CD-ROM drive of your PC. The [NEC Electronics Microprocessor Development Tools Setup] screen automatically appears.(if this screen does not appear automatically, start setup.exe from Explorer. etc.)

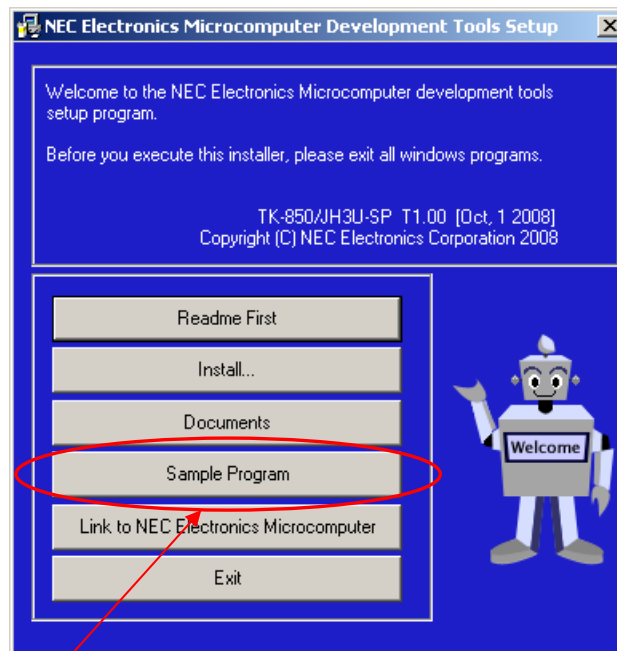

- ② Press the **Sample Program** button to start the WWW browser.

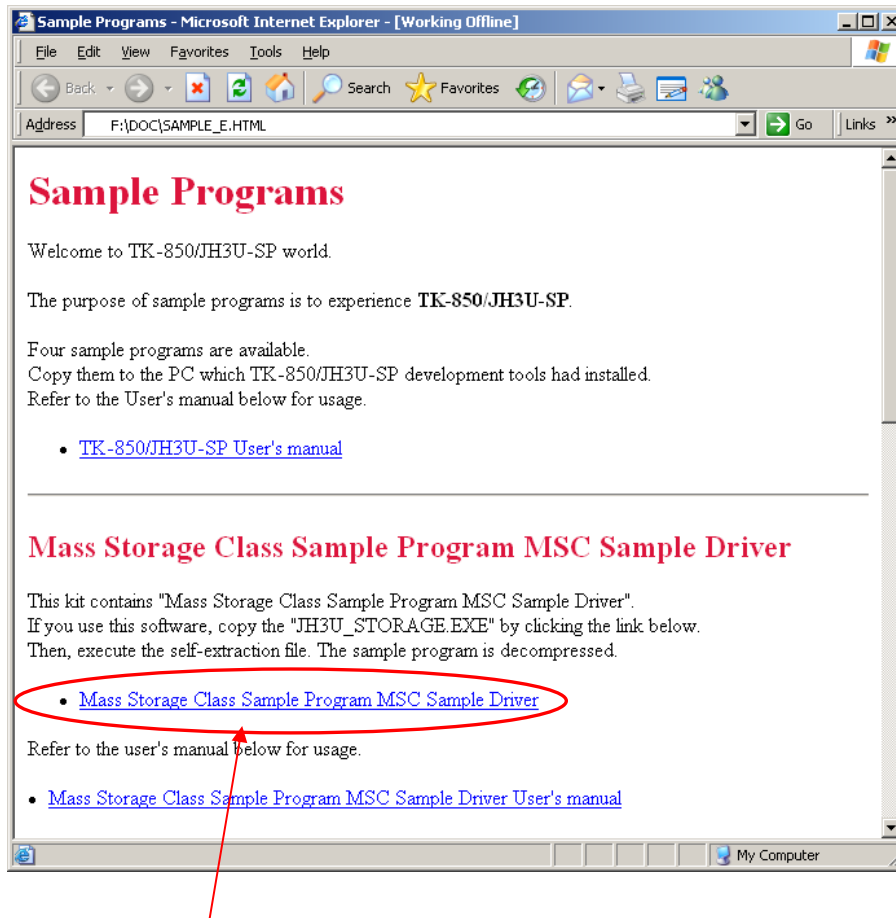

③ Click the “Mass Storage Class Sample Program MSC Sample Driver” link , the following download confirmation window appears.

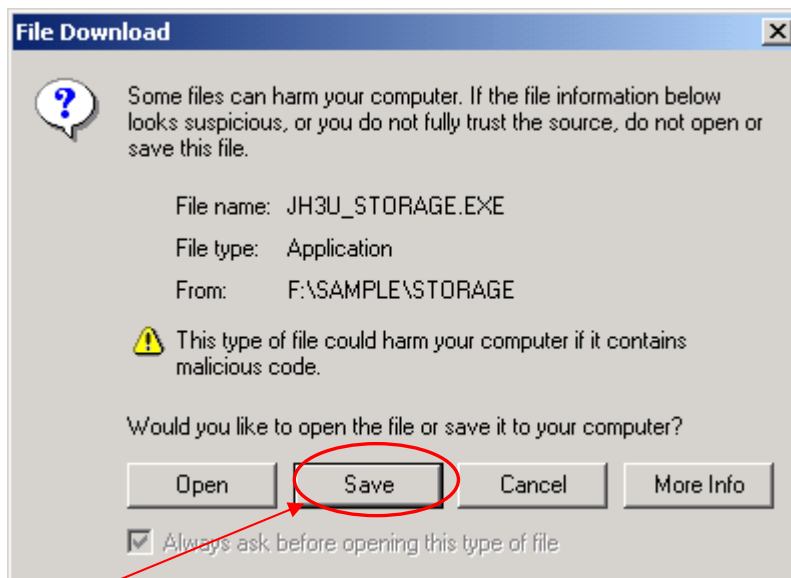

④ Click the **Save** button.

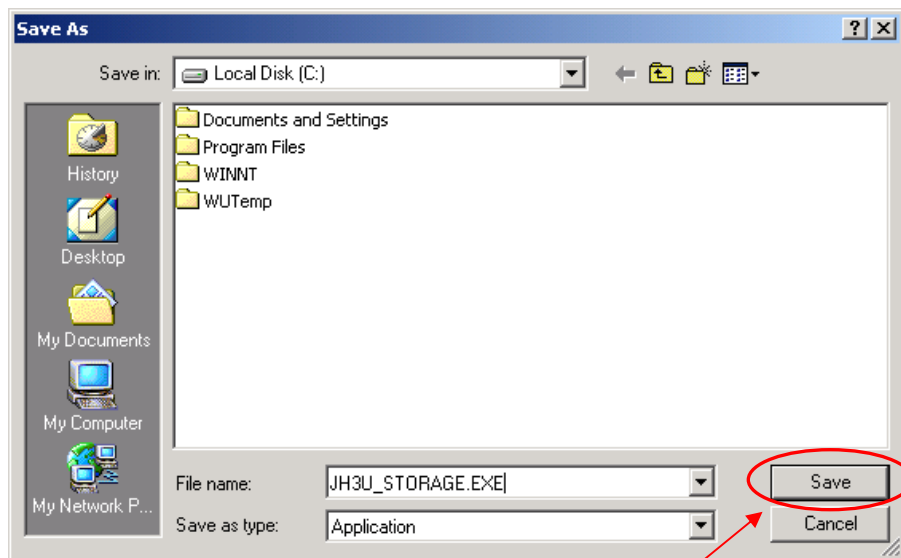

⑤ After specifying the download destination folder, click the **Save** button.

⑥ The self-extraction sample program (JH3U\_STORAGE.EXE) is copied to the specified folder. The folder that the “TK850” folder is made when this file is executed, and the sample program is stored under the “TK850” folder.

### 1.3.2 Overview of Sample Programs

The "Mass Storage Class Sample Program MSC Sample Driver" consist of following folders.

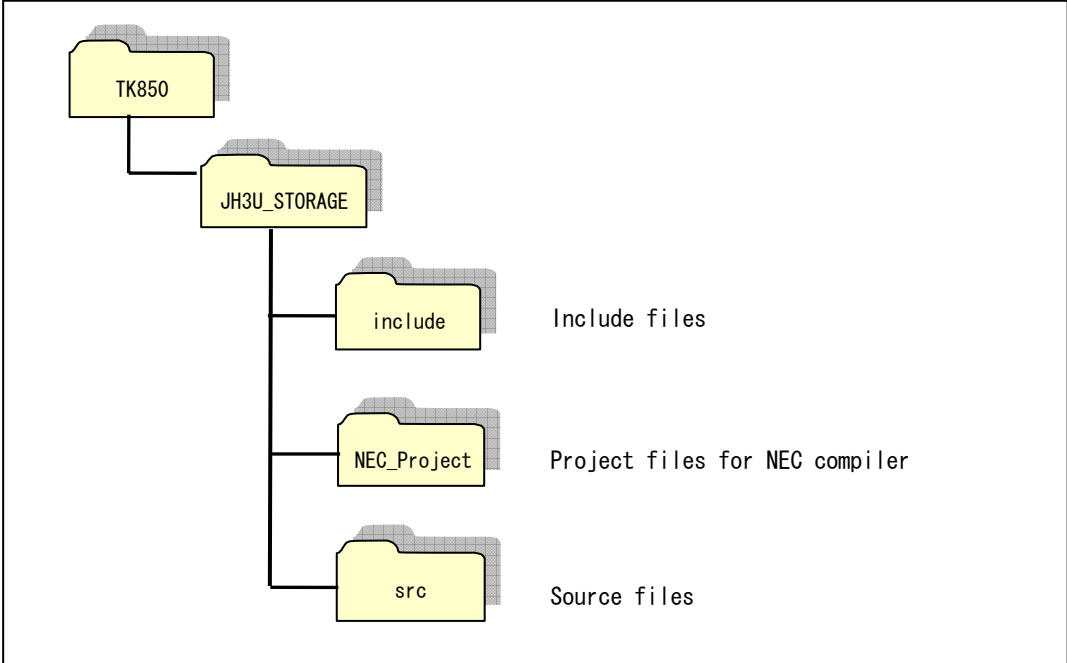

## 1.4 Installation of USB Driver

“NEC Electronics Starter Kit Virtual UART” USB driver must be installed on PC before you start using the TK-850/JH3U-SP.

Please, follow the instruction below to install the driver.

“Starter Kit USB Driver” must be installed on the PC. If not, please refer to “1.2 Installation of Development Tools” to install the driver first.

**CAUTION:**

**Do not use a USB hub for connecting TK-850**

First, connect the TK-850 to PC with USB.

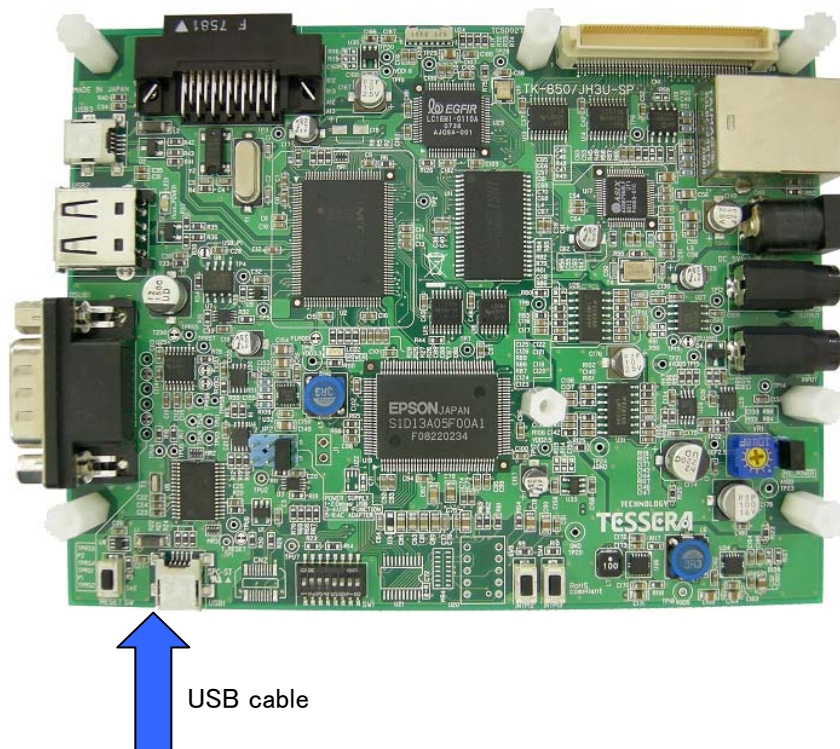

Depending on the version of Windows OS, the installation will be differed. Please check your Windows version, and follow the instructions

- Windows XP → “1.4.1 Installation on Windows XP”
- Windows 2000 → “1.4.2 Installation on Windows 2000”

After the installation, go to “1.4.3 Completion of USB Driver Installation”

### 1.4.1 Installation on Windows XP

1. Once the TK-850/JH3U-SP is connected with USB, the "Found New Hardware Wizard" will be started.

Select "No, not this time" and click **Next >** .



2. Select "Install from a list or specific location" and click **Next >** .

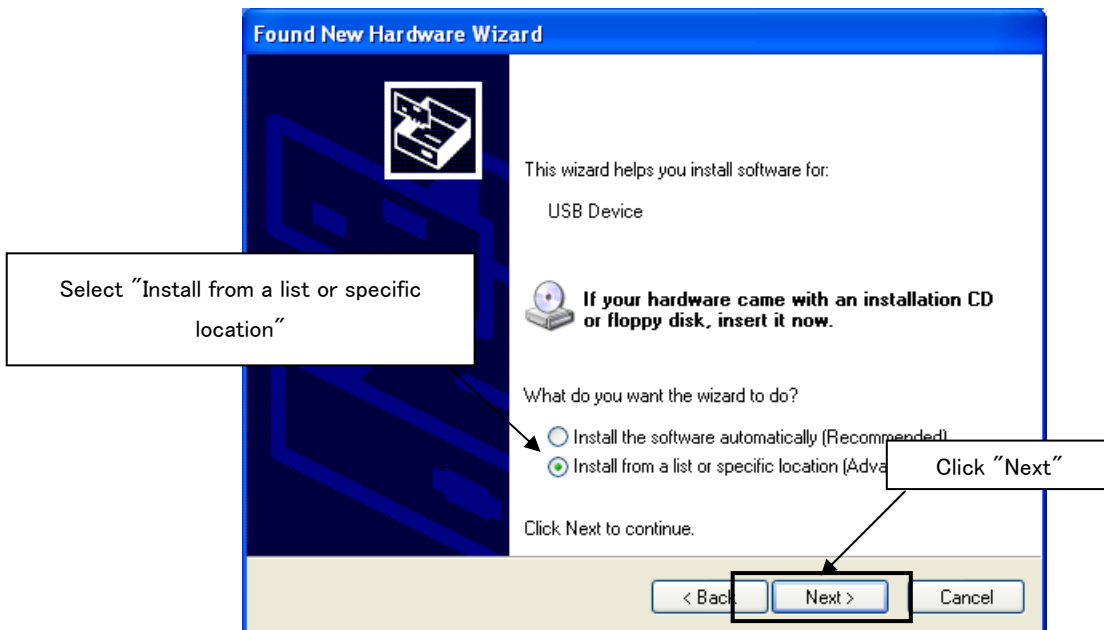

3. Select "Search for the best driver in these locations.", check "Include this location in the search:", and then click "Browse..." to select the driver directory path. The path should be "C:\Program Files\NEC Electronics Tools\TK-driver" as default installation. If the installation directory is not default, then select "TK-driver" under the installation directory.  
Click Next > .

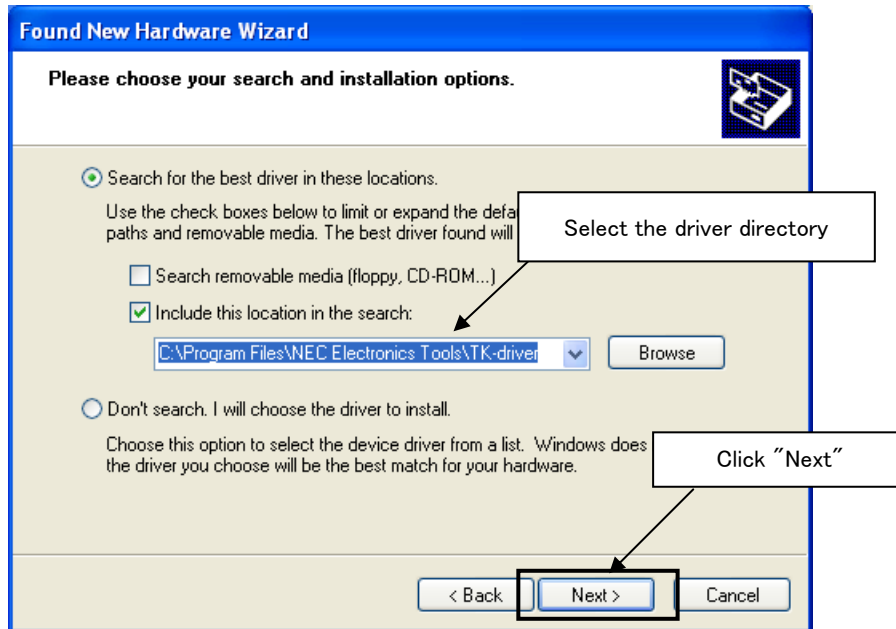

4. If the following dialog is opened, click Continue Anyway .

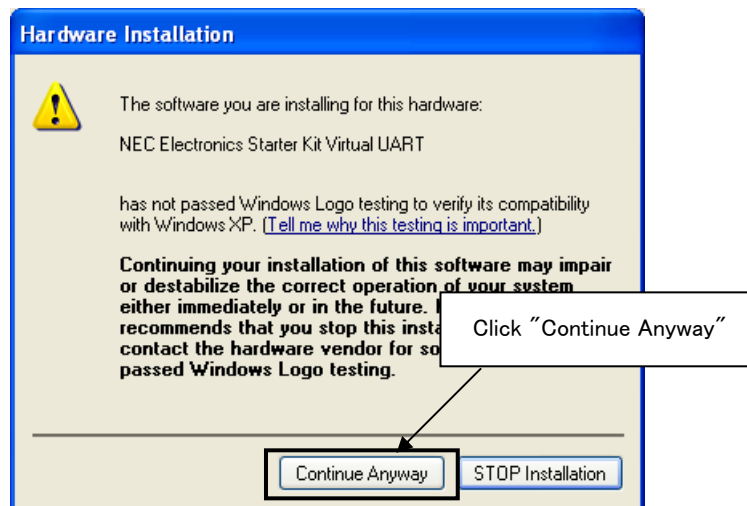

5. The installation of "NEC Electronics Starter Kit Virtual UART" driver is completed. Click **Finish** .

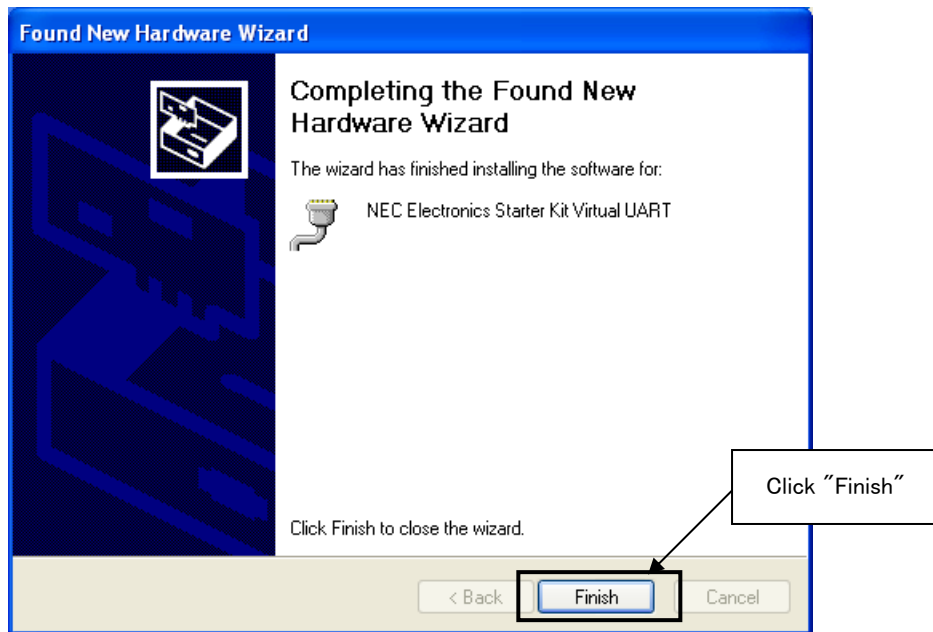

6. Go to "[1.4.3 Completion of USB Driver Installation](#)".

## 1.4.2 Installation on Windows 2000

1. Once the TK-850/JH3U-SP is connected with USB, the "Found New Hardware Wizard" will be started.

Select "No, not this time" and click **Next >** .



2. Select "Search for a suitable driver for my device".

Click **Next >** .

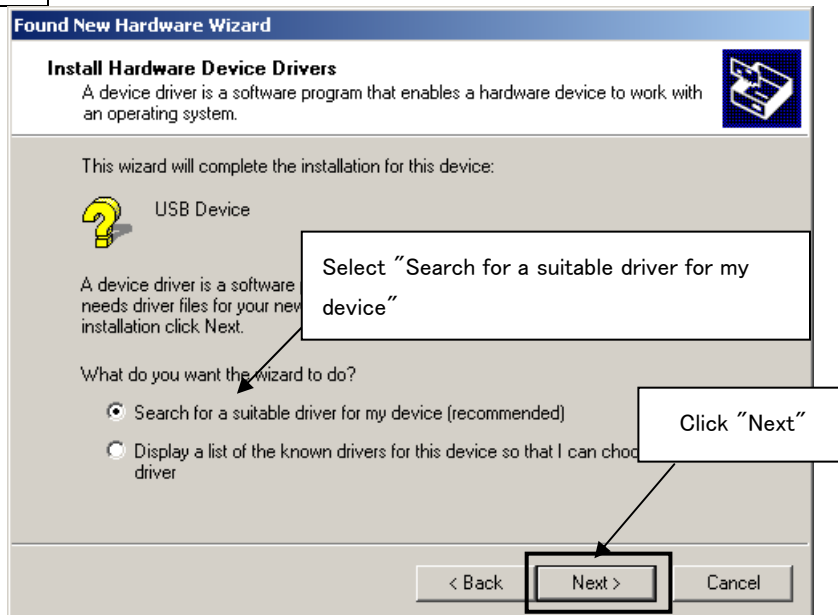

3. Select "Specify a location".  
Click **Next >** .

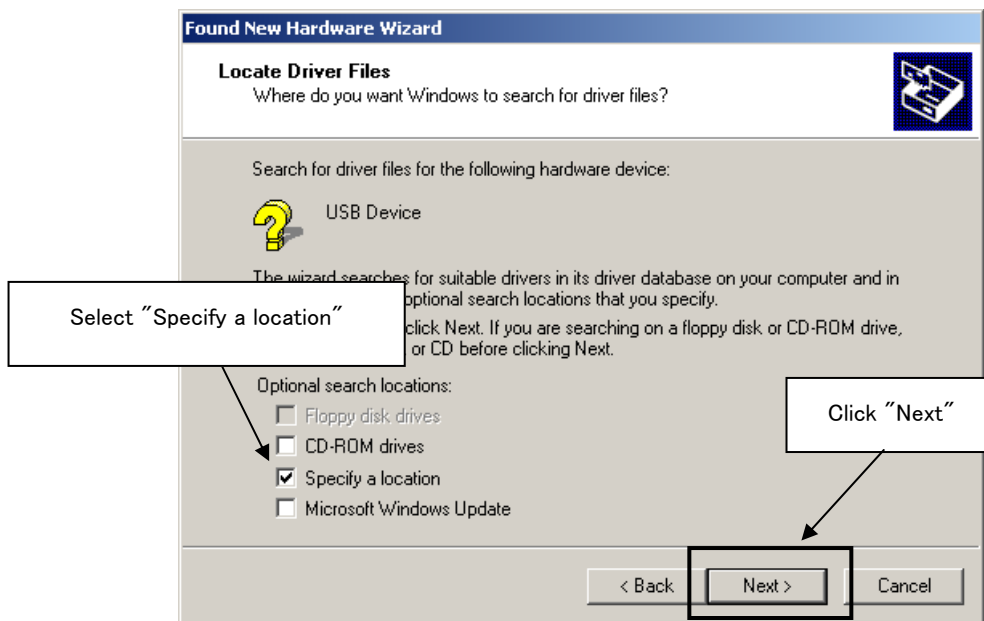

4. Select the driver directory path. The path should be "C:\Program Files\NEC Electronics Tools\TK-driver" as default installation.  
If the installation directory is not default, then select "TK-driver" under the installation directory.  
Click **OK** .

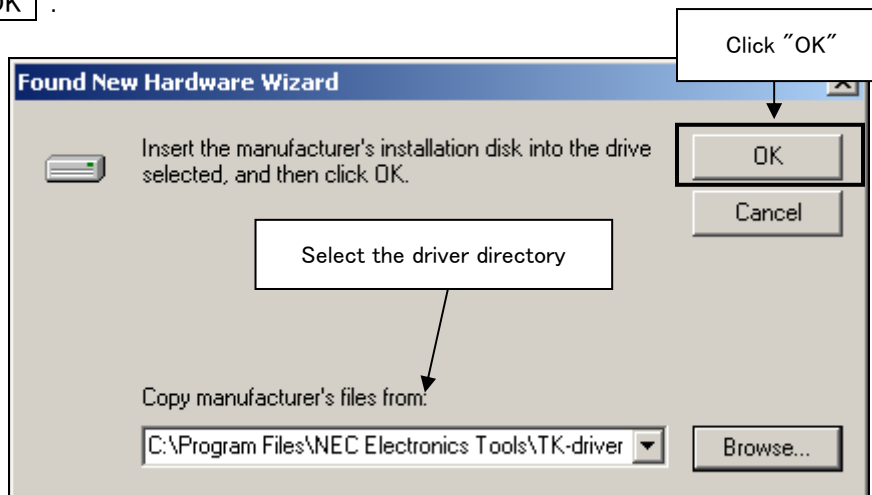

5. Click **Next >** .

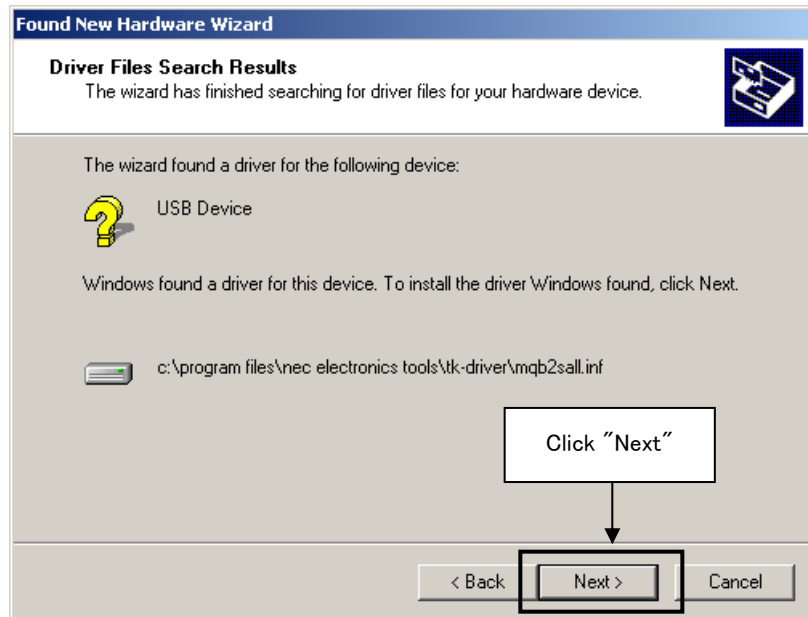

6. The installation of "NEC Electronics Starter Kit Virtual UART" driver is completed. Click **Finish** .



7. Go to "[1.4.3 Completion of USB Driver Installation](#)".

### 1.4.3 Completion of USB Driver Installation

Confirm the USB driver is installed on PC.

Start "Device Manager", and find "NEC Electronics Starter Kit Virtual UART" (without "?" mark) under the "Ports (COM & LPT)".

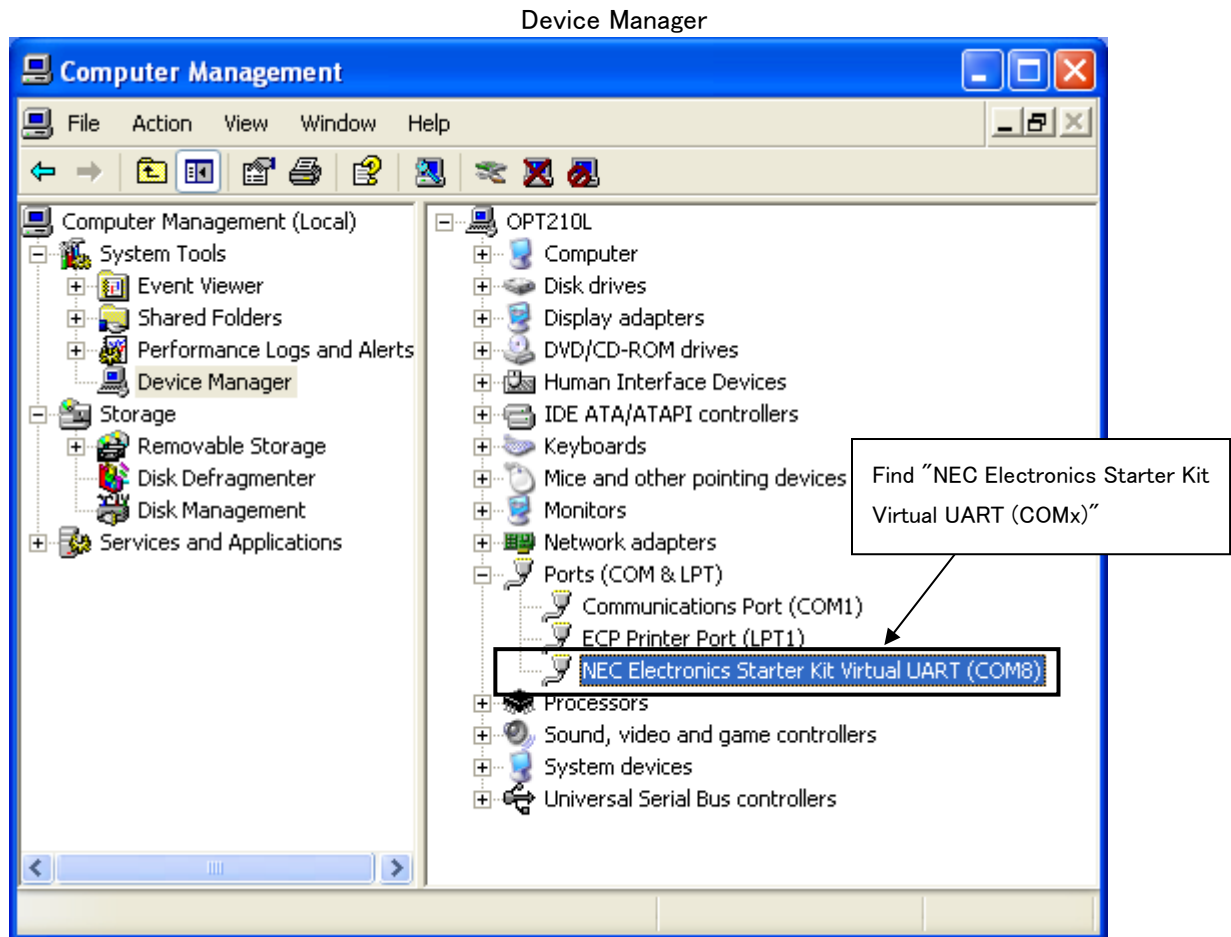

The screen above shows that the COM port number is "COM8". If ID850QB is not in use, you can use this port number for connecting TK-850/JH3U-SP.

When you change the USB port connection, the COM port number will be changed as well.

#### CAUTION

- Do not do "Hardware Modification Scan" when you communicate with the target device.

## CHAPTER 2 Experiences

In this chapter, you will experience how to use the development tools with using the sample programs.

The development tools are :

- Integrated Development Environment (IDE), PM+
- Integrated Debugger, ID850QB

You will use the programs that you prepared in "1.3 Sample Programs", as the sample programs for TK-850/JH3U-SP

You will be able to understand how to use the development tools and the concept of project files which you need for producing application programs.

The overall steps are as follows:

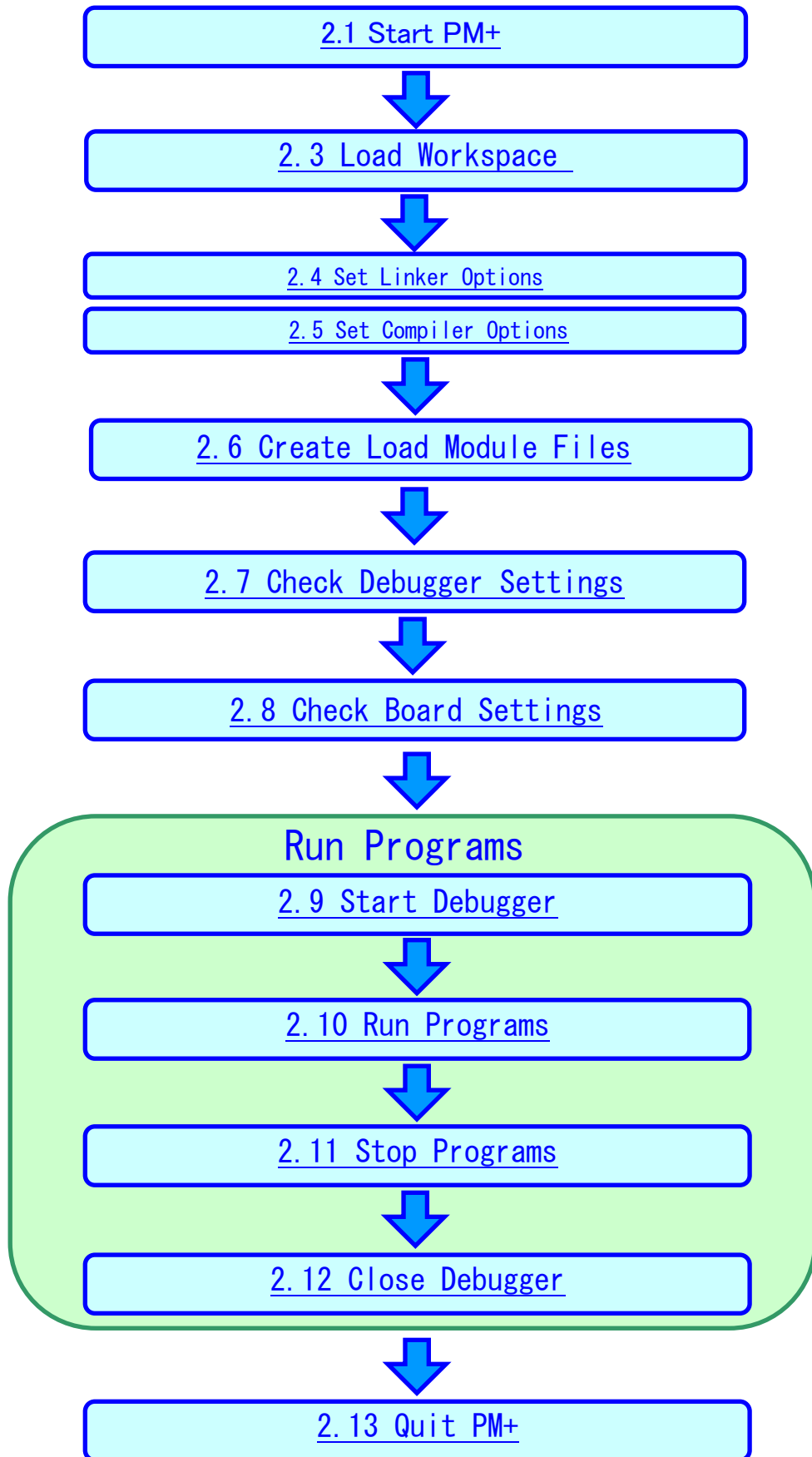

## 2.1 Start PM+

Let's start using the development tools.

First, start the PM+

Select "Windows Start Menu" -> "Program" -> "NEC Electronics Tools" -> "PM+ V6.31".

PM+ starts up

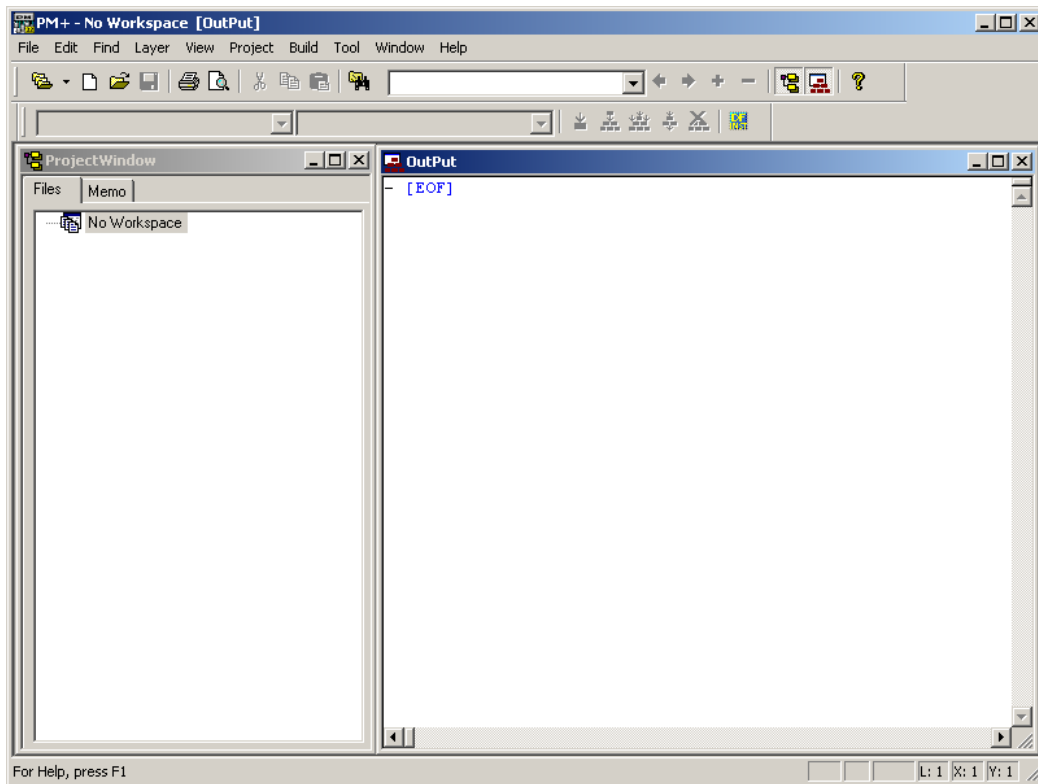

## 2.2 What is PM+

In PM+, application programs and environment setting are handled as a single project, and series of actions such as program creation using the editor, source management, build, and debugging are managed.

Also, one or more project files is managed together as a workspace.

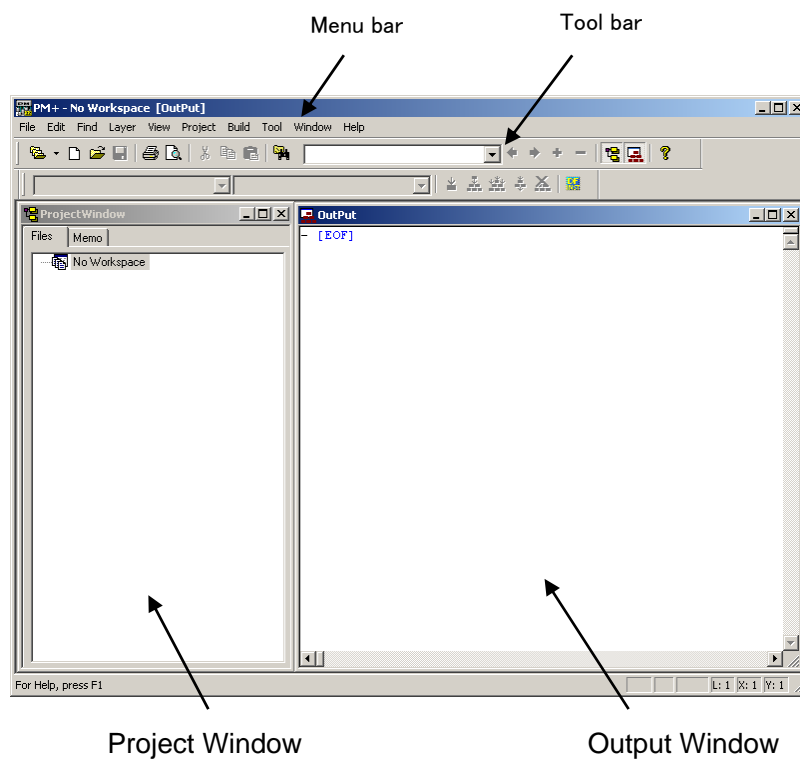

- Project window A window in which project names, source files, and include file are displayed using a tree structure.
- Output window A window in which the build execution status is displayed.

➡ For details regarding menu bars and tool bars, refer to "Help" menu in PM+. "Help" on menu bar , then "PM+ Help"

### **What is a project?**

A project is the unit that is managed by PM+. A project refers to an application system and environment development based on PM+.

PM+ saves project information in a "project file".

### **What is a project file?**

A project file contains project information that includes the source files, device name, tool options for compiling, editor, and debugger information.

The file name format is "xxxxx.prj".

Project files are created in the directory you specifies when you create a new workspace.

### **What is a project group?**

A project group is a group comprised of a number of projects in an application system.

The target device of each project must be the same within a project group.

### **What is a workspace?**

A workspace is the unit used to manage all the projects and project group required for one application system.

A workspace file contains one or more project files.

The file name format is "xxxxx.prw".

## 2.3 Load Workspace (project)

In this section, you will use the workspace that you created in "1.3 Sample Programs". For creating a new workspace, refer to "Chapter 5 Other Information". The workspace has information about the build environment for the sample programs.

Select "File" on menu bar and "Open Workspace...". Then, select "V850JH3U\_Fnc\_MSC.prw" under the directory "C:\TK850\JH3U\_STORAGE\NEC\_project".

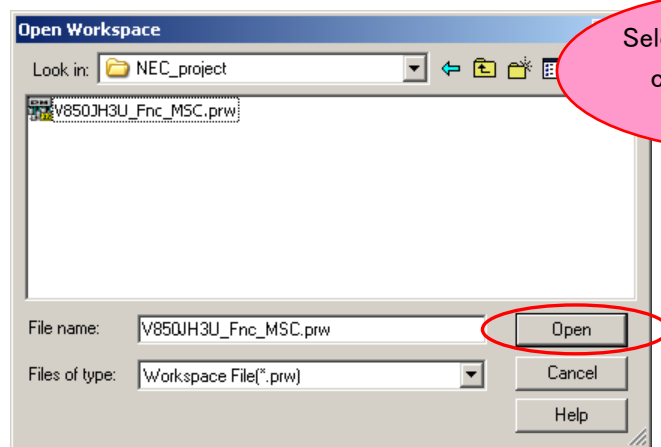
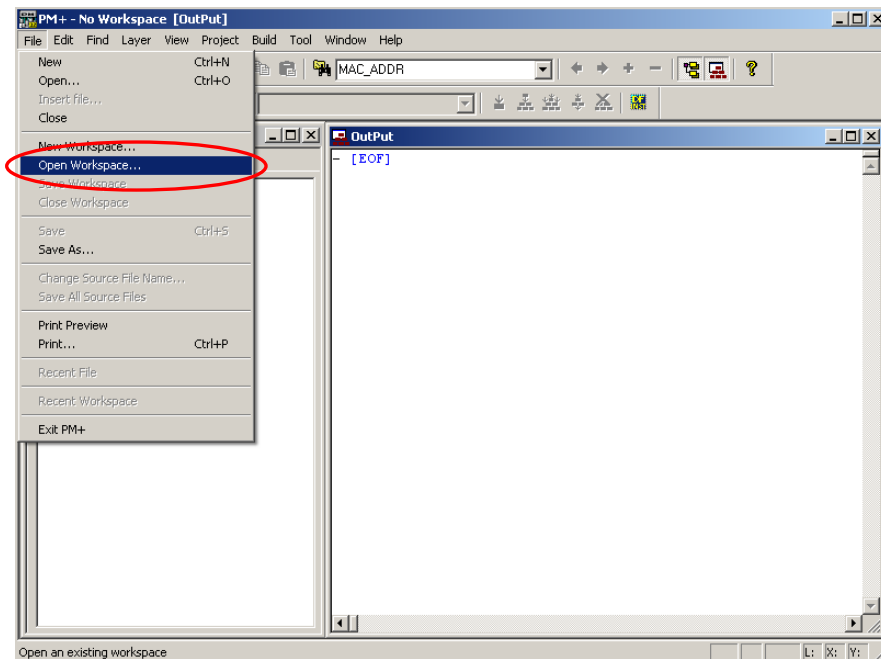

Select the directory that contains the sample programs.

Select "V850JH3U\_Fnc\_MSC.prw", then click Open .



Workspace name: "V850JH3U\_Fnc\_MSC.prw"

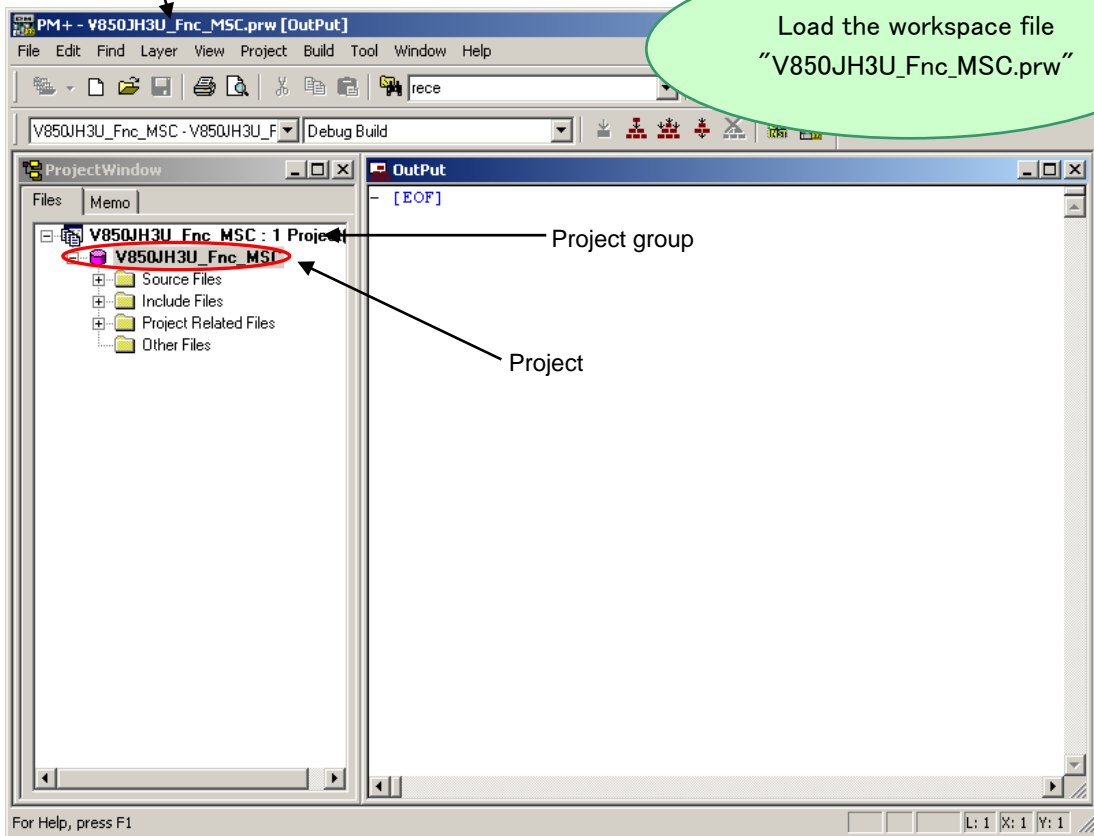

The workspace file "V850JH3U\_Fnc\_MSC.prw" contains one project called "V850JH3U\_Fnc\_MSC". You will use this project "V850JH3U\_Fnc\_MSC".

**CAUTION:**

Please ignore when you get a prompt saying "files could not be found". This may occur when the installation directory is not a default.

## 2.4 Set Options

The compiler options have been set by project file. However, because some compiler options are useful, following two settings are covered specifically in this section.

- Enable C++ comments
- On-chip debug (Disable/Enable, security ID)

Select "Tools" on menu bar, then "Compiler Common options".

### 2.4.1 "Extend" Tab

Select "Device" tab on "Compiler Common Options" window, and check following settings.

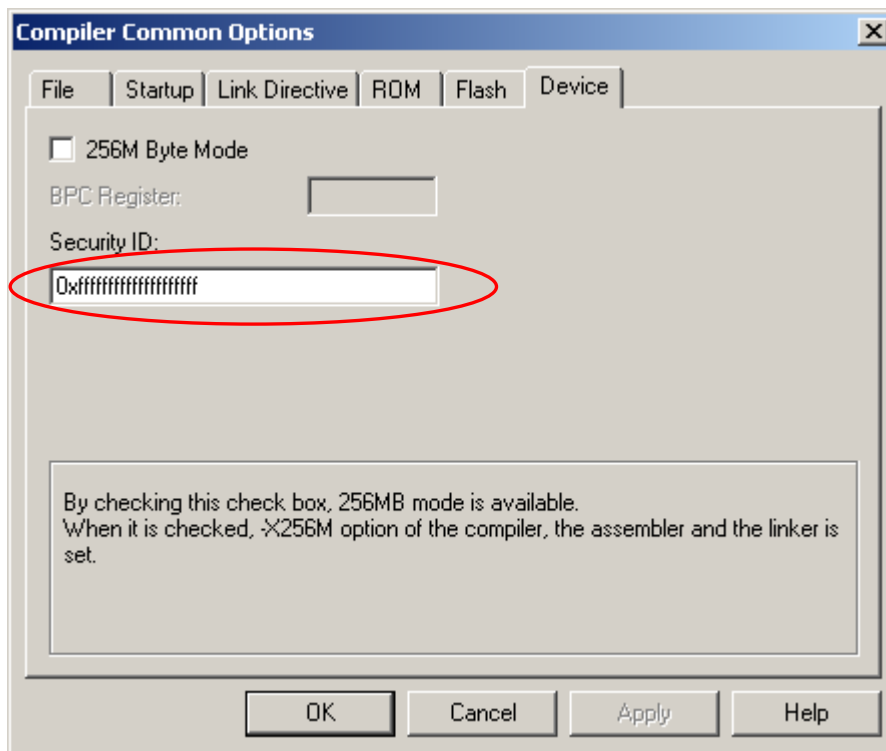

Set the security ID. The security ID is a specific ID code (10 bytes) used for the authentication when the debugger is starting. The security ID is stored at the address 70H-79H in the microcontroller built-in flash memory. The security ID in the flash memory and the ID entered in the configuration dialog are compared when the debugger is starting. When the ID does not match, the debugger cannot be started. Therefore, it is useful to protect the program data in the memory from others.

If you do not need to care about the security, it is recommended to enter "FFFFFFFFFFFFFFFF". (When you erase the data in the flash memory, the ID is set to this value.)

If you forgot the security ID code stored in the address 70H-79H, the debugger (ID850QB) will not be able to start.

In this case, you need to use "WriteEZ1" to erase the built-in flash memory. By erasing the flash memory, the security ID is set to "FFFFFFFFFFFFFFFFFFFF".

For details, refer to "[5.4 WriteEZ1](#)".

## 2.4.2 "Preprocessor" Tab

Select "Tool" on menu bar in PM+, then "Compiler Options...".

Select "Preprocessor" tab, and check "Use C++ Style Comment".

This setting allow you to use the C++ comment using "///  
It is useful feature when editing programs.

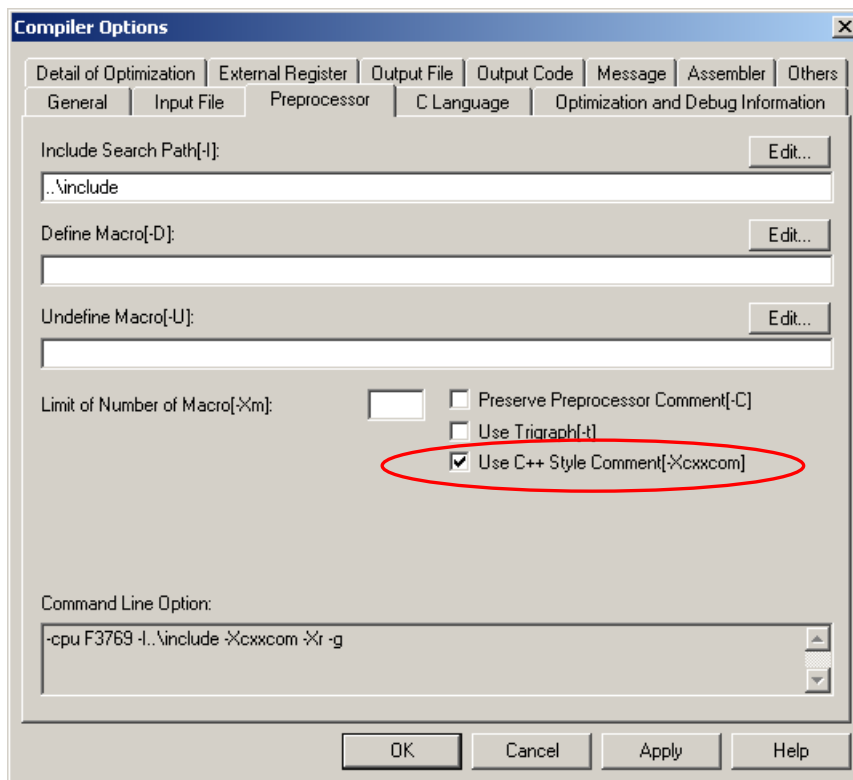

## 2.5 Create Load Module Files

After developing the source code, you have to create load module files by compiling, assembling, and linking. This process is called build.

Click the build button  , or select "Build" on menu bar, then "Build".

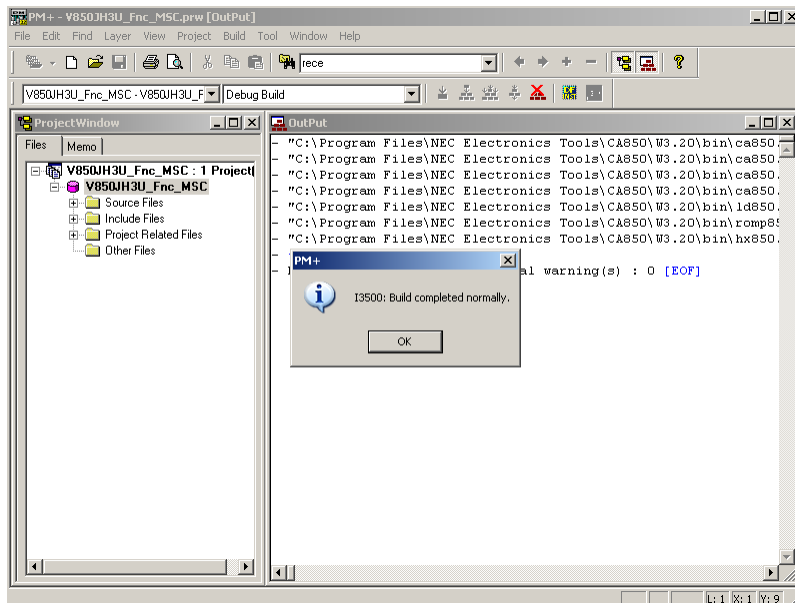
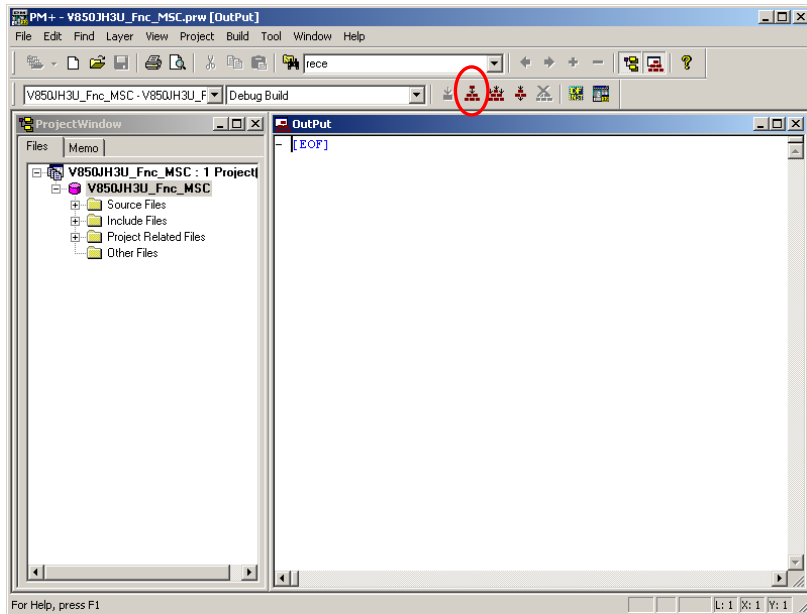

Build has been completed successfully.

**What is build?**

Build is a function that creates an executable file from source files in a project.

PM+ automatically performs compiling, assembling, linking, and other processing actions.

To reduce the time for the build, PM+ detects and compiles/assembles only the files that have been updated from the previous build process.

**What is rebuild?**

Build compiles and assembles only the source files that have been updated from the previous time, whereas rebuild compiles and assembles all the source files.

When setting, such as compiler options, have been changed, you must rebuild instead of build.

## 2.6 Check Debugger Settings

After the build, you should configure the debugger settings.

The debugger settings have been set by the project file as well. However, because those settings are important for debugging, some settings are covered in this section.

Select "Tools" on menu bar, then "Debugger Setting...".

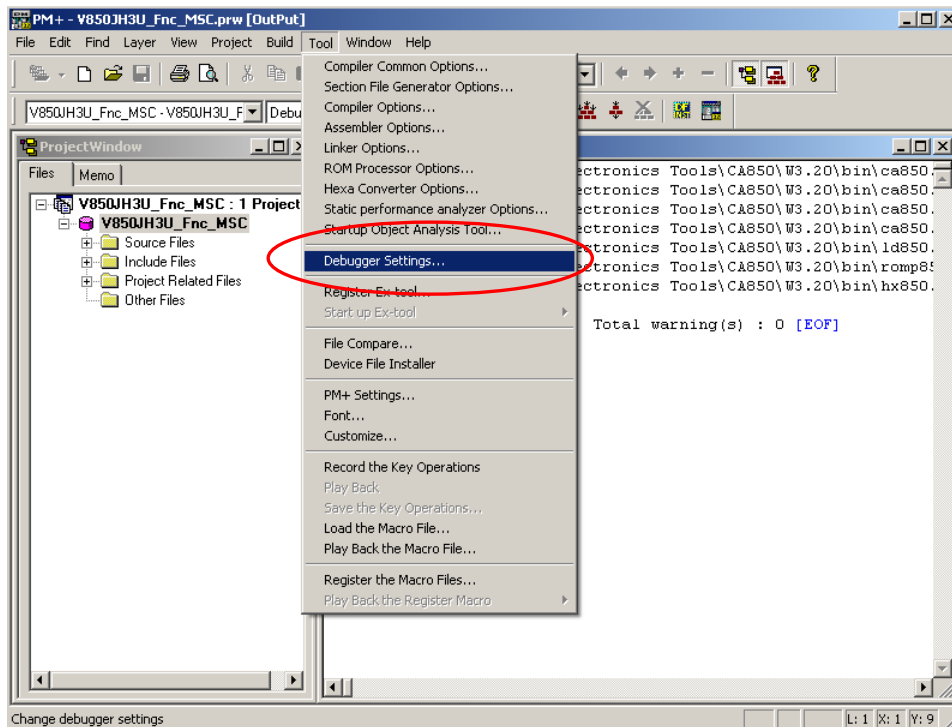

Check if "ID850QB V3.50 V850 Integrated Debugger" is selected on "Debugger".

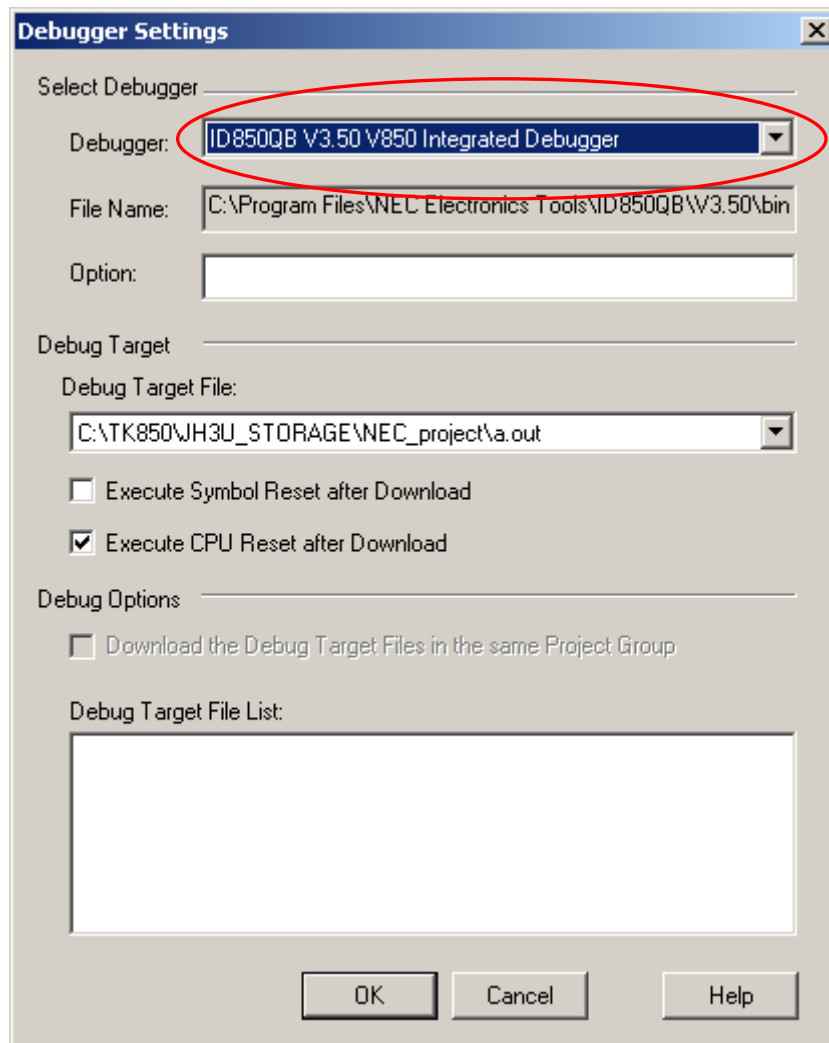

If you cannot select "ID850QB V3.50 V850 Integrated Debugger", select "Project" on menu bar, "Project settings" -> "Tool version settings" -> "Detailsetting" -> then select "ID850QB V3.50".

## 2.7 Check Board Settings

Before connecting the PC and the TK-850/JH3U-SP with USB, you should check the setting of SW1 on the board.

- ① Set JP2 and SW1 as shown below.

JP1 : 1-2 short

SW1

Bit1	OFF
Bit2	ON
Bit3	ON
Bit4	ON

- ② Connect USB1 connector on TK-850/JH3U-SP and PC with USB cable.

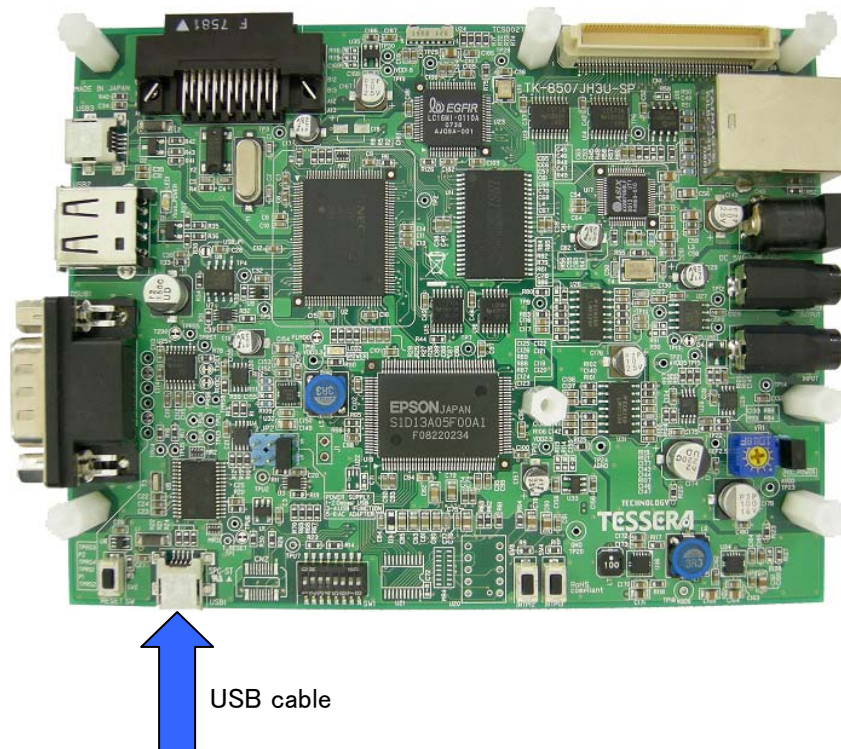

## 2.8 Start Debugger (ID850QB)

Click the debug button  , or select "Build" on menu bar, then "Debug".

If you do not see the debug button, go to "2.7 Check Debugger Settings" for changing the settings.

The steps to start the debugger will be explained below.

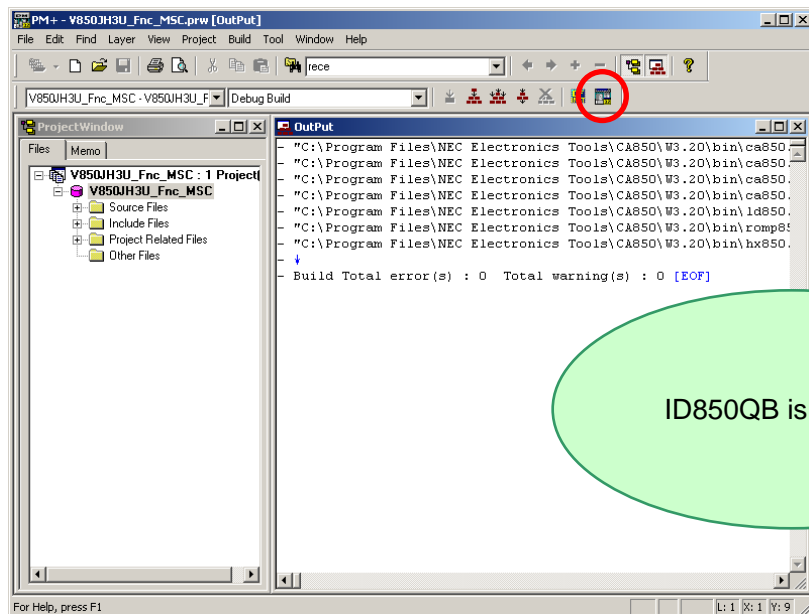

"Configuration" dialog is opened. Follow the settings below and click "OK".

- Enter "6" in "Main OSC"
- Enter "8" in "Multiply rate"
- Enter "FFFFFFFFFFFFFFFF" (F x 20) in "ID Code".
- Select "UARTD0" in "Port" at "Target Device Connection" area then click  .

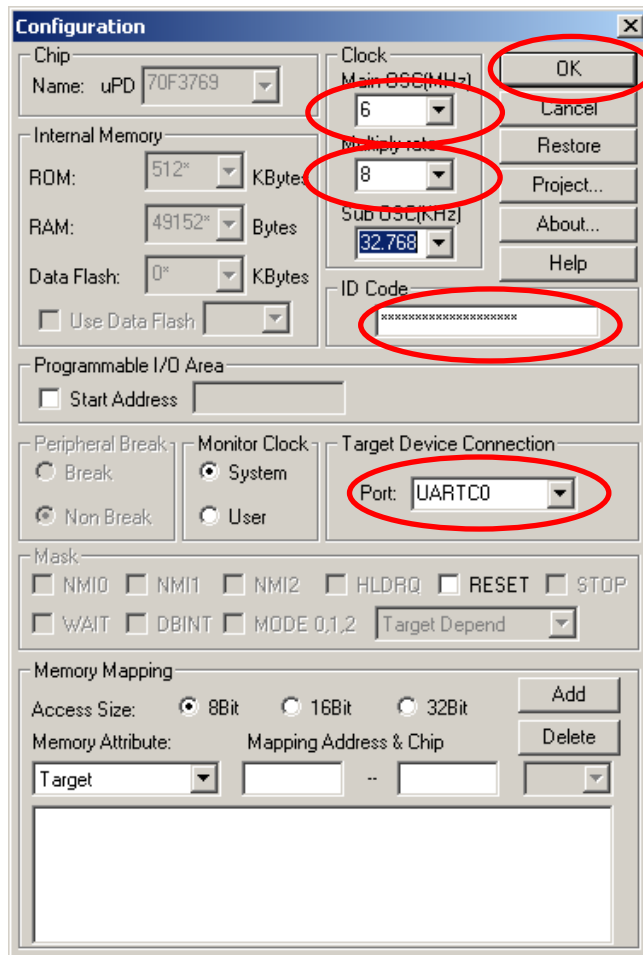

Click  when the confirmation dialog for downloading load module file is opened.

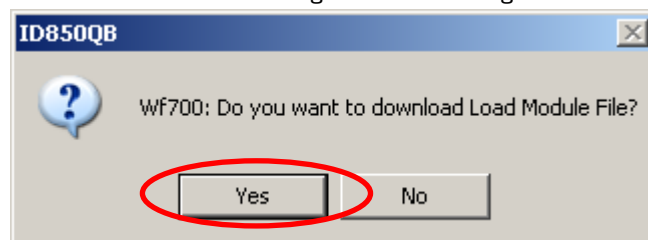

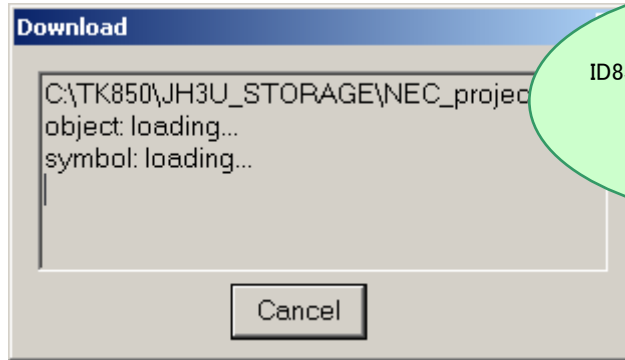

ID850QB starts and downloading the program to flash memory.



When the download is completed, the source code will be displayed

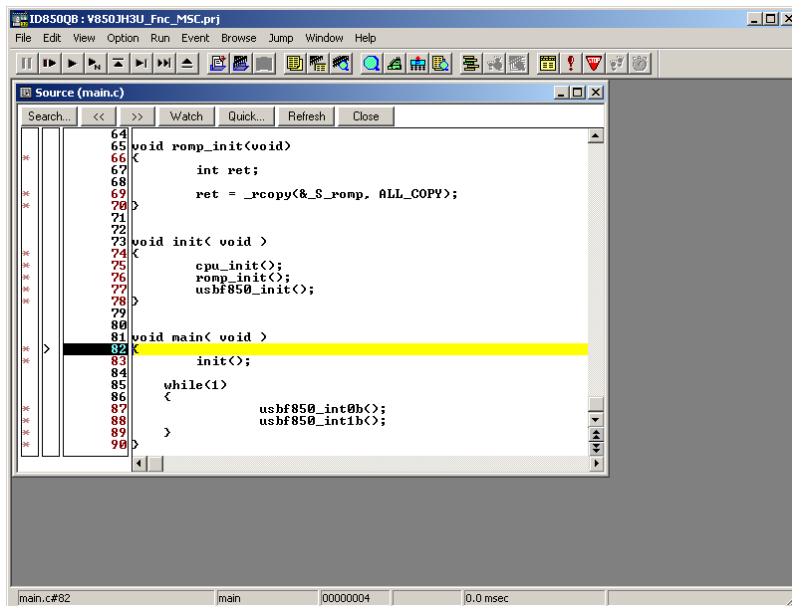

**NOTE:**

Completion of the download does not mean running the programs. Therefore, even though you press switch on the board, it does not make anything happened. To run the sample program demonstration, see "2.9 Run Programs".

## 2.9 Run Programs

Now, you are ready to run the program.

Click the restart button  , or select "Run" on menu bar, then "Restart".

The sample program runs.

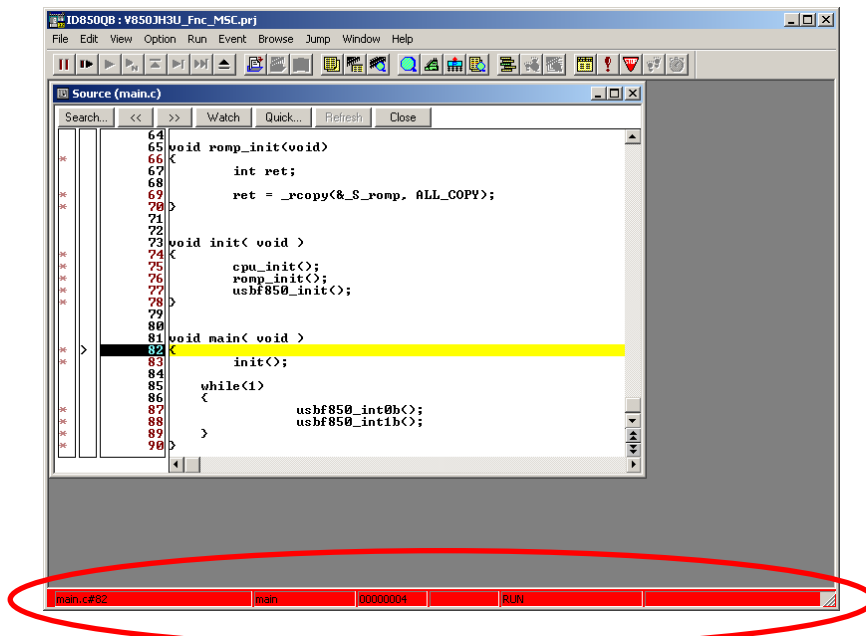
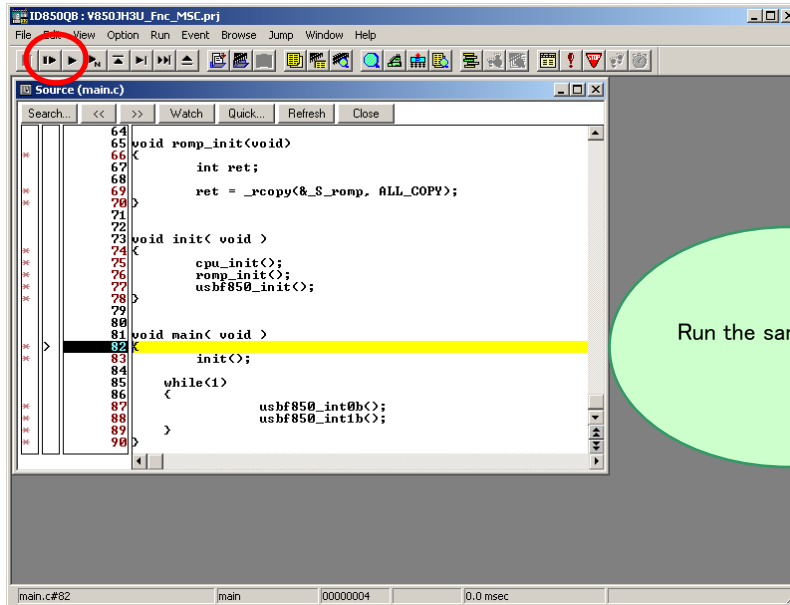

When programs are running, the status bar will be red.

Connect USB3 and PC with another USB cable while USB1 is still connected.

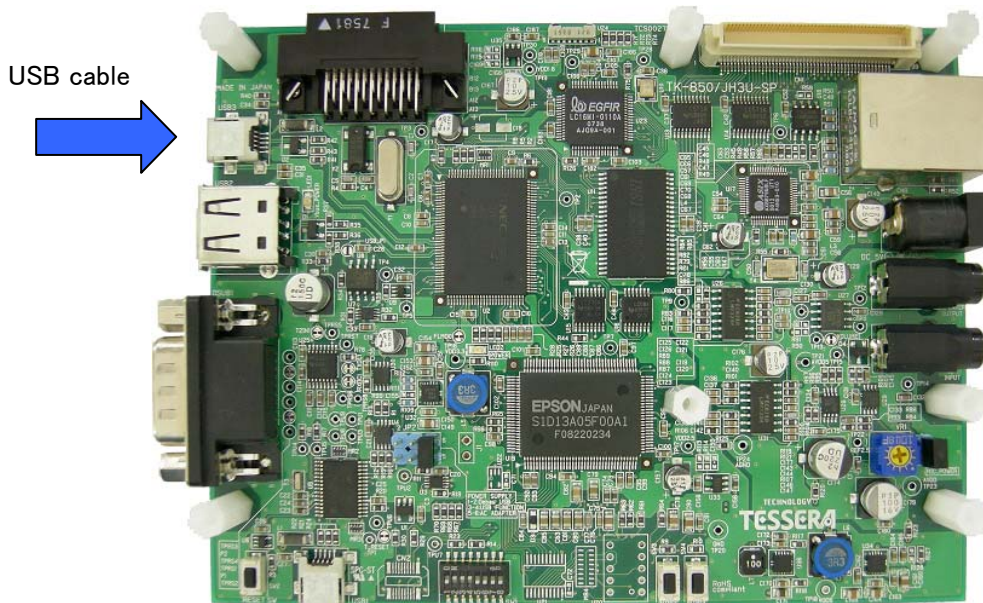

When it is connected to PC, the driver is automatically installed. It is detected as "NEC corp TK-850JG3-H/JH3- USB Device" under disk drive.

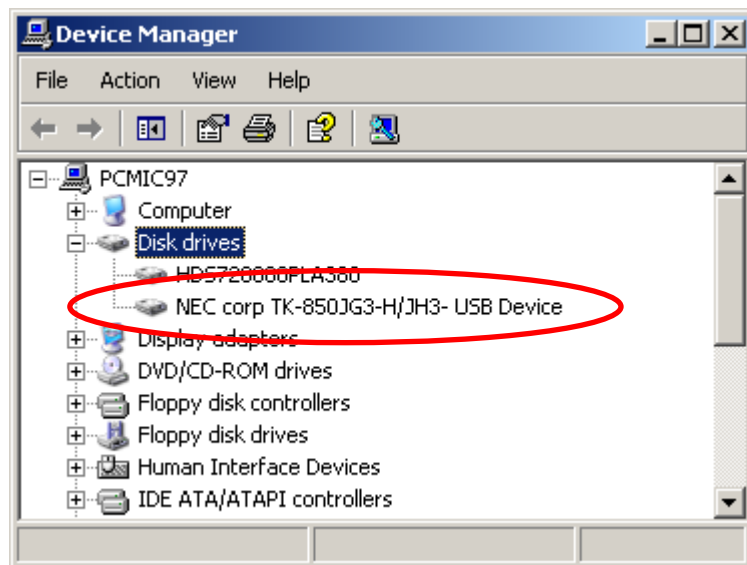

Also, the removable disk is added as a disk drive.

This drive is not formatted. You can use this as 24KB removable disk when you format it.

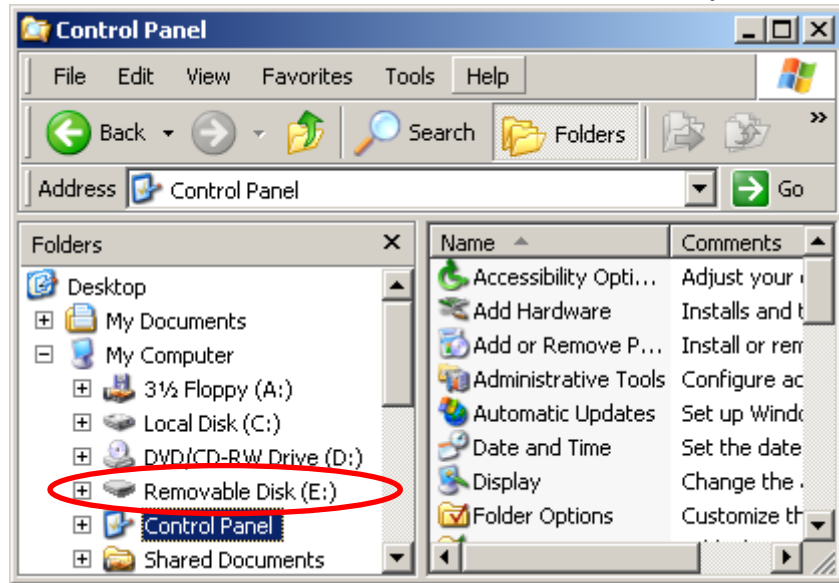

Now you could check the mass storage class (MSC) sample program is functioning.

- The program downloaded with ID850QB cannot be executed without ID850QB connection. If you need to execute it with stand-alone, use WriteEZ1 to write HEX file. For more information, refer to "5.4 WriteEZ1".

## 2.10 Stop Programs

Now, you are going to stop the program.

Click the stop button  , or select "Run" on menu bar, then "Stop".

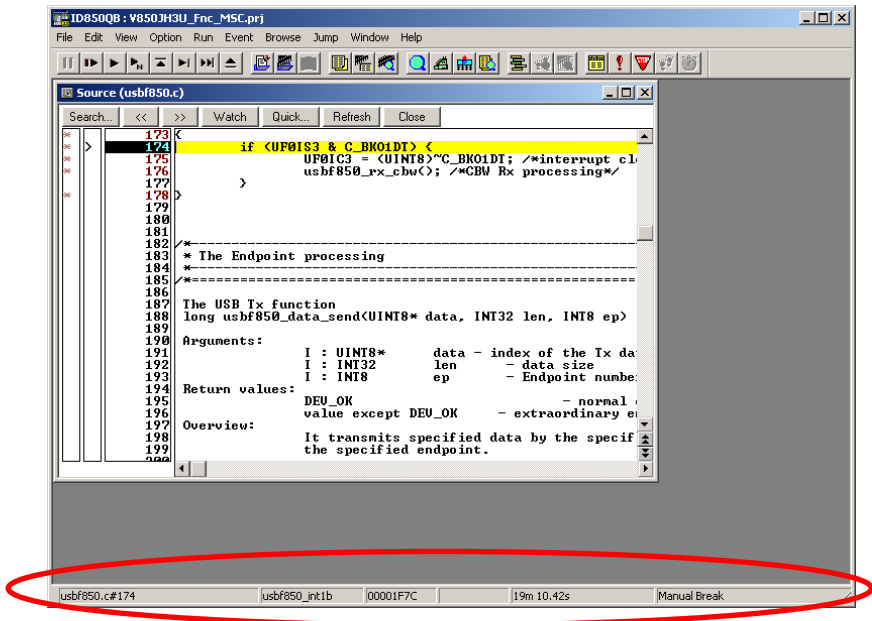
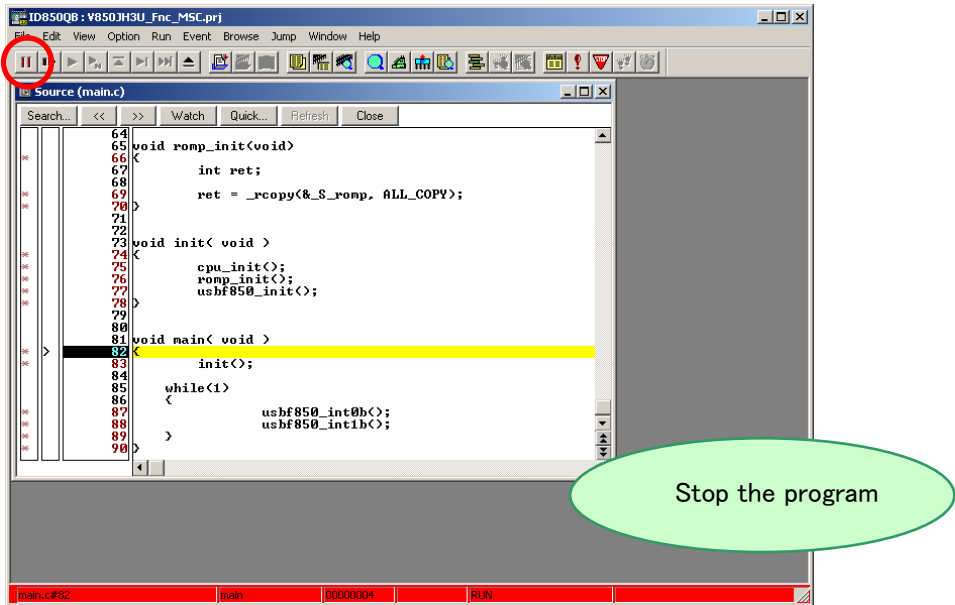

When the program stops, the status bar changes back to the original color.

## 2.11 Close Debugger (ID850QB)

Select "File" on menu bar, then "Exit".

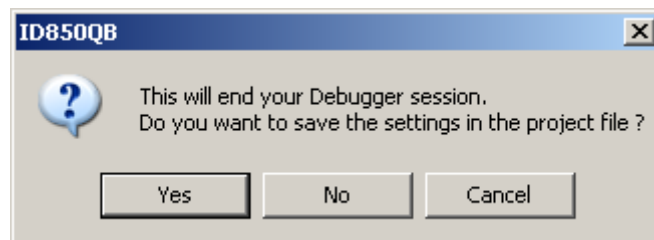
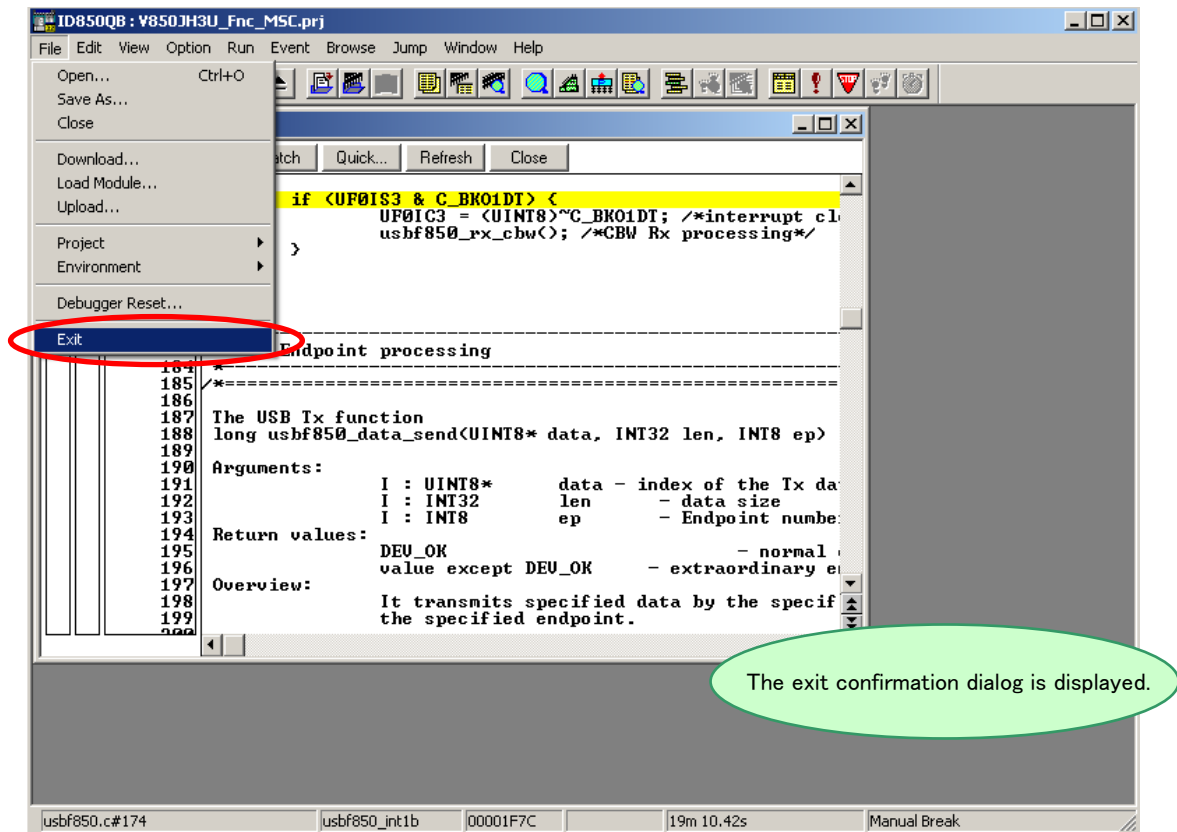

If you click  , it saves the settings in the project file, and then closes the ID850QB. It is recommended to save the settings as it saves the window you used, window size, layout, etc.

If you click  , it does not save the settings and closes the ID850QB.

## 2.12 Quit PM+

Select "File" on menu bar, then "Exit PM+".

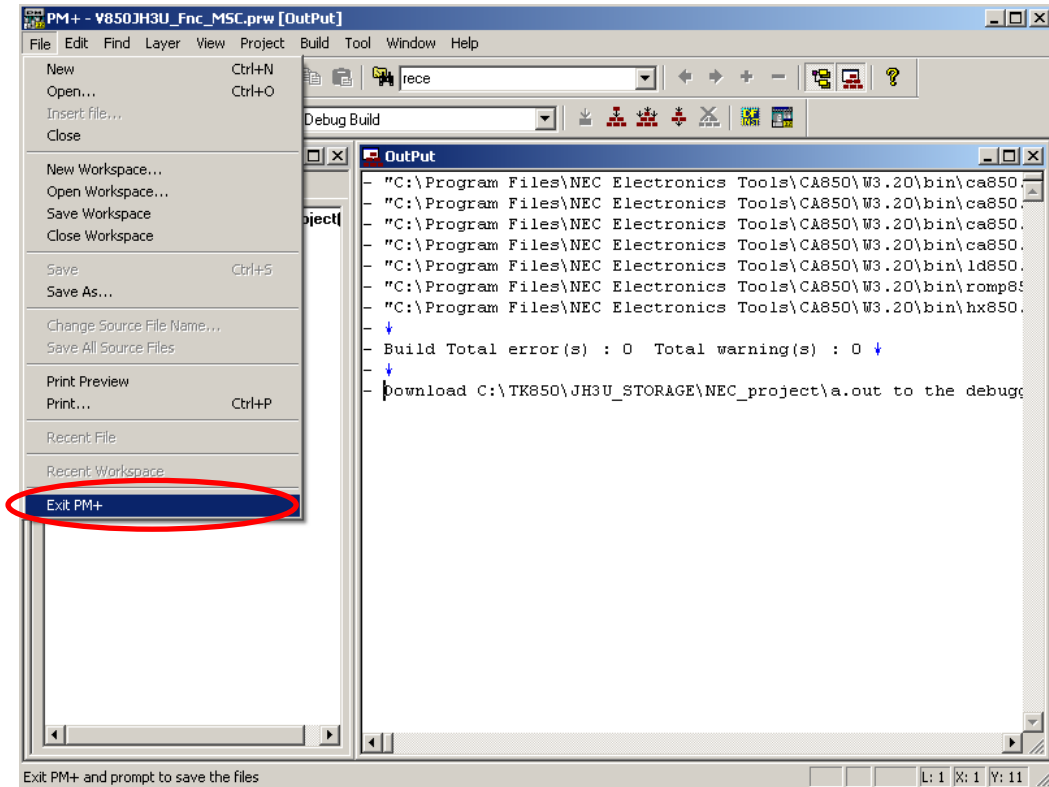

PM+ is closed.

The experiences section ends now.

You can find more information how to use the development tool and information about other useful features in "[Chapter 5 Other Information](#)".

## CHAPTER 3 Hardware Specifications

In this chapter, the hardware of TK-850/JH3U-SP will be explained.

Microcontroller	$\mu$ PD70F3769 ※V850ES/JH3-U
Clock	External main system clock: 48MHz (6MHz x8) Sub-clock: 32.768KHz
Interface	USB (A receptacle) x1 USB (MINI B connector) x2 Connector for N-Wire (For KEL connector) Connector for MINICUBE2 (For SICA connector only pad) Dsub-9Pin x1 Expansion connector (50Pin) RJ-45 connector IrDA communication interface Audio input ( $\phi$ 3.5mm monaural jack) Audio output ( $\phi$ 3.5mm monaural jack) AC adopter jack (5V)
Other unit	Touch panel LCD (for LCD version) 7Seg-LED (for no LCD version)
Dimension	100mm x 136mm
Power supply voltage	5V

### 3.1 Connector Layout

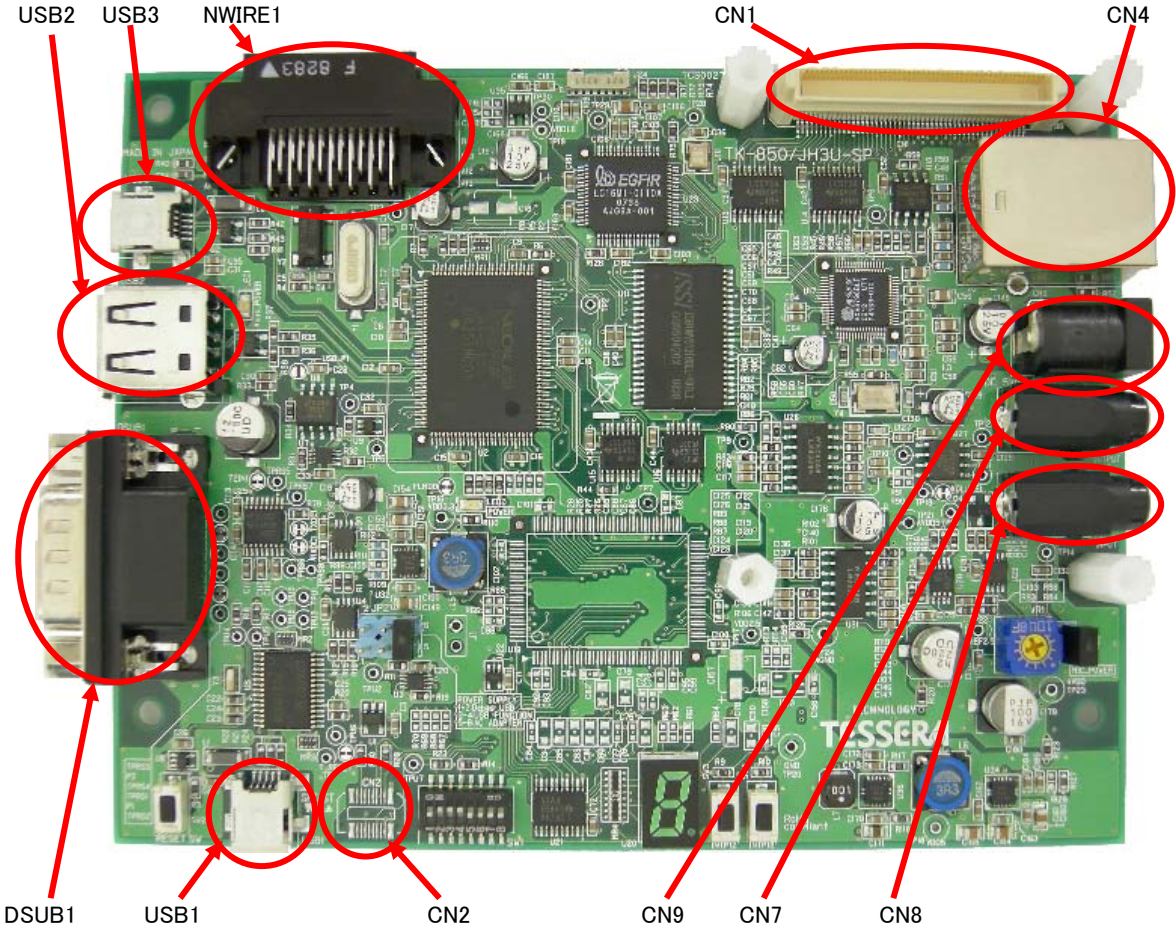

### 3.2 Function Layout

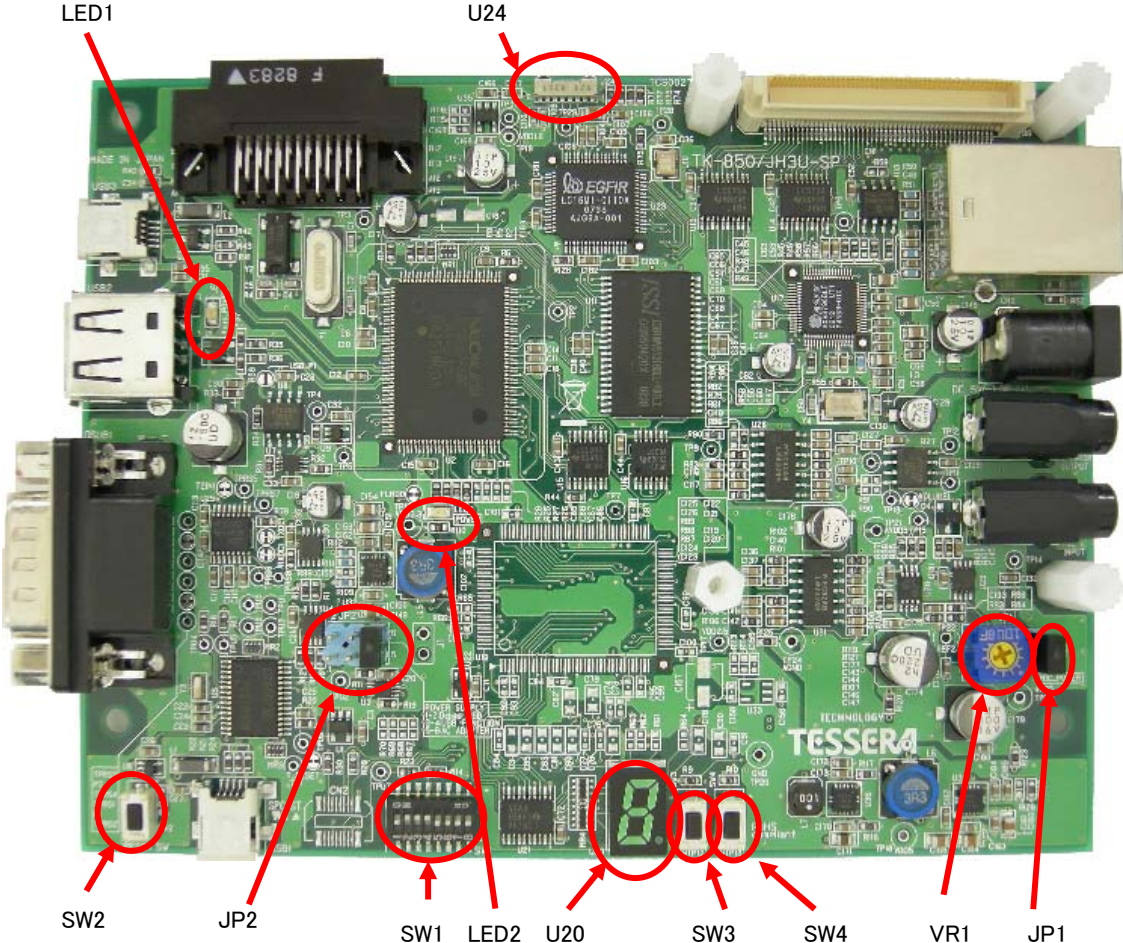

## 3.3 Hardware Functions

### 3.3.1 SW1

The bit 1-4 on SW1 are for mode settings, Bit5-8 of SW1 are connected to "P78/ANI8" ~ "P711/ANI11" for general-purpose input port.

- For the use of ID850QB, use following settings.

SW1

Bit1	OFF
Bit2	ON
Bit3	ON
Bit4	ON

- \* When ID850QB is used, these terminals cannot be used because it communicates with the host machine by using and the terminal P30 and P31.

- Please change to the following settings when writing it in the flash memory with built-in CPU by using WriteEZ1. (The hardware of WriteEZ1 is built into TK-850/JH3U-SP.)

SW1

Bit1	OFF
Bit2	ON
Bit3	ON
Bit4	ON

- To run the programs stored in built-in flash memory by WriteEZ1, use following settings and re-supply power.

SW1

Bit1	OFF
Bit2	OFF
Bit3	OFF
Bit4	OFF ※

※If you need to use USB1 as virtual serial port, set Bit4 to ON.

- Please change to the following settings when you connect N-Wire emulator.

SW1

Bit1	OFF
Bit2	OFF
Bit3	OFF
Bit4	OFF

- Please change to the following settings when you use virtual serial COM port.

SW1

Bit1	OFF
Bit2	OFF
Bit3	OFF
Bit4	ON ※

※If you need to use USB1 as virtual serial port, set Bit4 to ON.

- Bit5-8 are connected to following CPU pins.

As they are connected to pull-up resistor, "ON" means "Low" and "OFF" means "High".

SW1

Bit5	P78
Bit6	P79
Bit7	P710
Bit8	P711

### 3.3.2 SW2 (RESET SW)

This is the reset switch. You can reset the microcontroller by pressing this switch.

### 3.3.3 SW3 (INTP12)

SW3 is the push switch connected to "P98/SOF1/INTP12/A8" pin in CPU. There are connecting to pull-up resistor. When the switch is pushed down, it sends the signal of "Low".

### 3.3.4 SW4 (INTP13)

SW4 is the push switch connected to "P99/SCKF1/INTP13/A9" pin in CPU. There are connecting to pull-up resistor. When the switch is pushed down, it sends the signal of "Low".

### 3.3.5 LED1

This is the Bus Power LED for USB2 connector. It is lighted when USB2 connector gets power supply.

### 3.3.6 LED2 (POWER)

This is the POWER LED. It is lighted when it gets power supply.

### 3.3.7 U20 (for no LCD version)

This is the 7Seg-LED.

7Seg-LED display can be changed by accessing the address between 600000h and 6FFFFFFh.

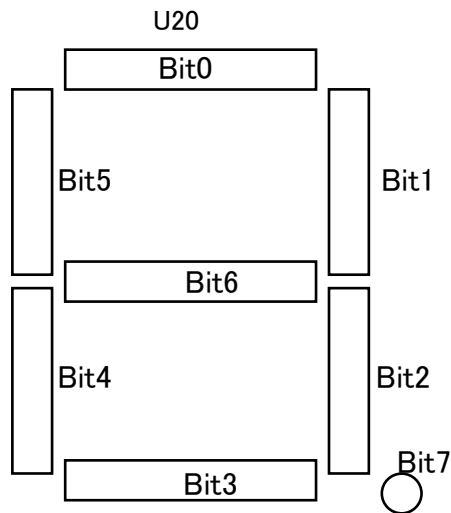

Example of displayed figure and set data.

0	0xC0	5	0x92
1	0xF9	6	0x83
2	0xA4	7	0xf8
3	0xB0	8	0x80
4	0x99	9	0x98

### 3.3.8 JP1

JP1 is a jumper short pin to select power supply for CN8 MIC INPUT.  
Set the jumper to short when you connect electret condenser microphone.

### 3.3.9 JP2

JP2 is a jumper short pin to select power supply.

1-2 short	Use power supply from USB1 connector.
3-4 short	Use power supply from USB3 connector.
5-6 short	Use power supply from AC adapter connected to CN9.

#### Caution

When you use USB host connection with USB2 or use LCD display, you must use power supply from AC adapter.

### 3.3.10 CN1

CN1 is an extended connector.  
FX8C-100P-SV6 connector by Hirose Electric Co., LTD. is mounted.

### 3.3.11 CN2

CN2 is a connector pad for MINICUBE2 connection (connector is not mounted).

### 3.3.12 CN4

CN4 is RJ-45 connector socket for Ethernet connection.

### 3.3.13 CN7

CN7 is an audio output connector.  
P10/ANO0 signal output is output through low-pass filter.  
Connect  $\phi$  3.5mm mini plug.

### 3.3.14 CN8

CN8 is an audio input connector.  
P72/ANI2 inputs signal through low-pass filter.  
Connect  $\phi$  3.5mm mini plug.

### 3.3.15 CN9

CN4 is the power supply connector of the AC adaptor.  
You can supply the power by setting the JP2 to 5-6 short and connect AC adapter.

### 3.3.16 J1

This is the connector for external power supply. (DC5V)

### 3.3.17 NWIRE1 Connector

These are connector for N-Wire emulator.  
It can connect N-Wire emulator of IE-V850E1-CD-NW etc.  
8831E-026-170L-F connector by KEL Corp. is mounted.

### 3.3.18 USB1 Connector

This is a connector for on-chip debug and flash memory writing.  
This can be used as a virtual serial COM port by setting SW1.

### 3.3.19 USB2 Connector

This is a connector for USB host connection.

#### Caution

When you use USB host connection with USB2 or use LCD display, you must use power supply from AC adapter.

### 3.3.20 USB3 Connector

This is a connector for USB function connection.

### **3.3.21 DSUB1 Connector**

This is a Dsub-9Pin connector for RS-232C communication.

RS-232C communication can be made with using P90/TXDC1 and P91/RXDC1.

### **3.3.22 U24 (IrDA Infrared communication module)**

This is an IrDA infrared communication module.

### **3.3.23 VR1**

This is an initial level volume control for the audio input (CN8) signal.

### 3.4 solder-short pad label

When using an external connector without using a circuit on board, in order to separate a circuit on board, the terminal of CPU can be customized by making the pad for solder short opening.  
Pad for solder-short has shape like the figure below.

When you make an open circuit, cut the narrow part of the Pad with a knife.  
To make short circuit, join the separated Pad with a soldering iron etc.

Solder-short pad  
(opened shape)



Solder-short pad  
Shorted shape



Solder-short pad name	State when shipping it	Connection
T_RESET	Short	Connect reset IC to T_RESET signal ----- Open when reset IC is not in use.
FLMD0	Short	FLMD0 to P37 on CPU ----- Short when built-in flash memory is rewritten by self
USB_P1	Open	USB Host bus power switch output ----- Short when you set maximum bus power output current to 1A.
TXDC1	Short	Connect P90/TXDC1 and RS-232C driver. ----- Open when you use it not for RS-232C.
RXDC1	Short	Connect P91/RXDC1 and RS-232C driver. ----- Open when you use it not for RS-232C.
P1	Short	Connect RTC and CTS of RS-232C. ----- Open when RTC and CTS should be disconnected.
P2	Short	Connect DSR and DTR of RS-232C. ----- Open when DSR and DTR should be disconnected.
VOLUME1	Short	Audio output volume signal and P11/ANO1 ----- Open when P11/ANO1 should be disconnected.

## 3.5 Explanation of unit

### 3.5.1 USB function

- USB connector Mini B receptacle

USB Function block diagram

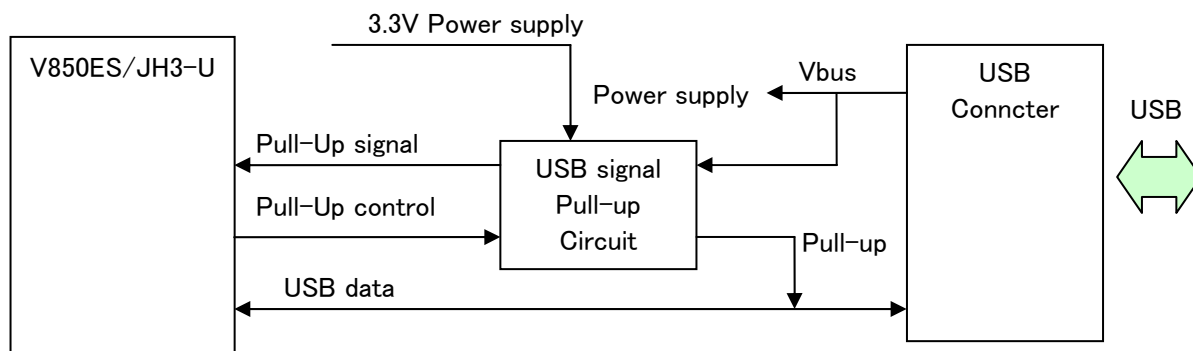

V850ES/JH3-U pin	Connector	V850ES/JH3-U Signal direction	Note
UDPF	D+	I/O	3.3V 1.5kΩ Pull-up
UDMF	D-	I/O	
P41/SOF0/RXDC4/SCL01	-	Out	D+ Pull-up control
P42/_SCKF0/INTP10	-	In	D+ Pull-up signal

### 3.5.2 USB Host

- USB connector A receptacle
- When you use USB host connection with USB2, you must use power supply from AC adapter for supplying USB bus power.

USB Host block diagram

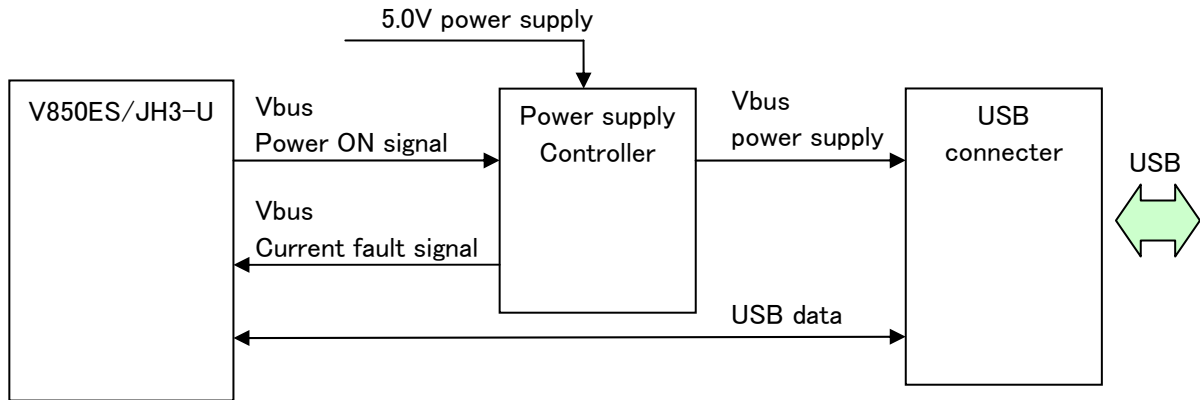

V850ES/JH3-U pin	Connector	V850ES/JH3-U Signal direction	Note
UDPH	D+	I/O	
UDMH	D-	I/O	
P34/TIAA10/TOAA10/TOAA1OFF/INTP09/PPON	-	Out	Vbus Power ON
P35/TIAA11/TOAA11/RTC1HZ/OCI	-	In	Vbus Current fault signal

### 3.5.3 IrDA infrared communication

- IrDA controller                      ITX E-Gloaledge LC16MI-0110A
- IrDA module                         ROHM RPM971-H14
- IrDA controller register base address 0x400000

IrDA block diagram

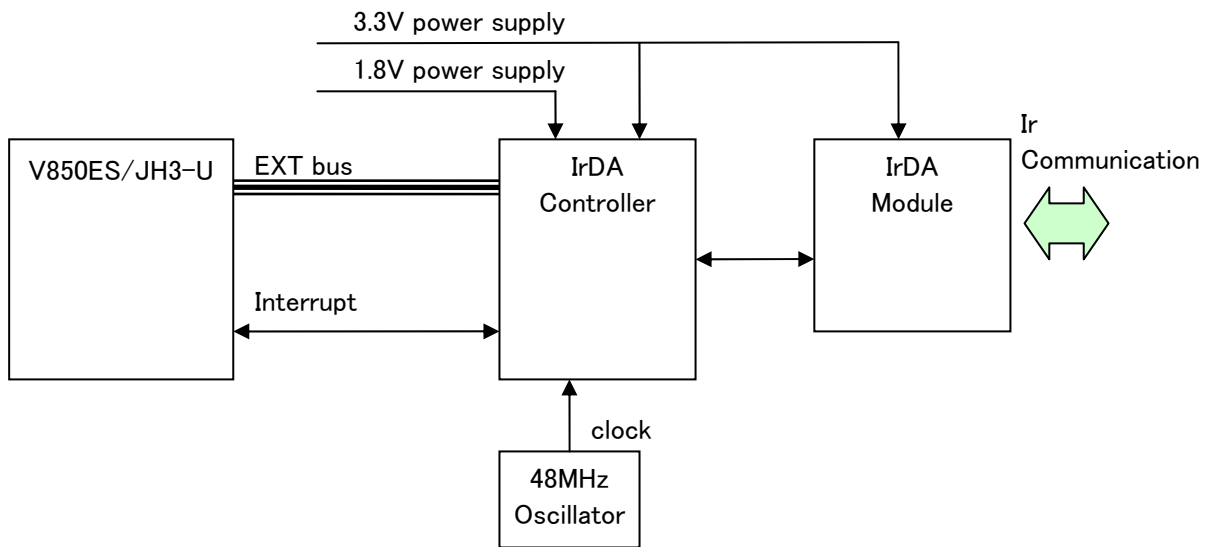

IrDA controller pin	V850ES/JH3-U pin	V850ES/JH3-U Signal direction	Note
A0~A7	A1~A8	Out	
D0~D7	AD0~AD7	I/O	
_RD	_RD	Out	
_WE	_WR1	Out	
_CS	→		Connect to address decoder
_INTR	P05/INTP04	In	Interrupt to CPU
_RESET	→		Connect to reset circuit
XIN/CLK48M	-	-	Input from shared USB clock

### 3.5.4 Ethernet

- LAN controller ASIX AX88796B
- RJ45 Jack With Magnetic Module TAIMAG RJLBC-248TA1
- Ethernet controller register address 0x500000

Ethernet block diagram

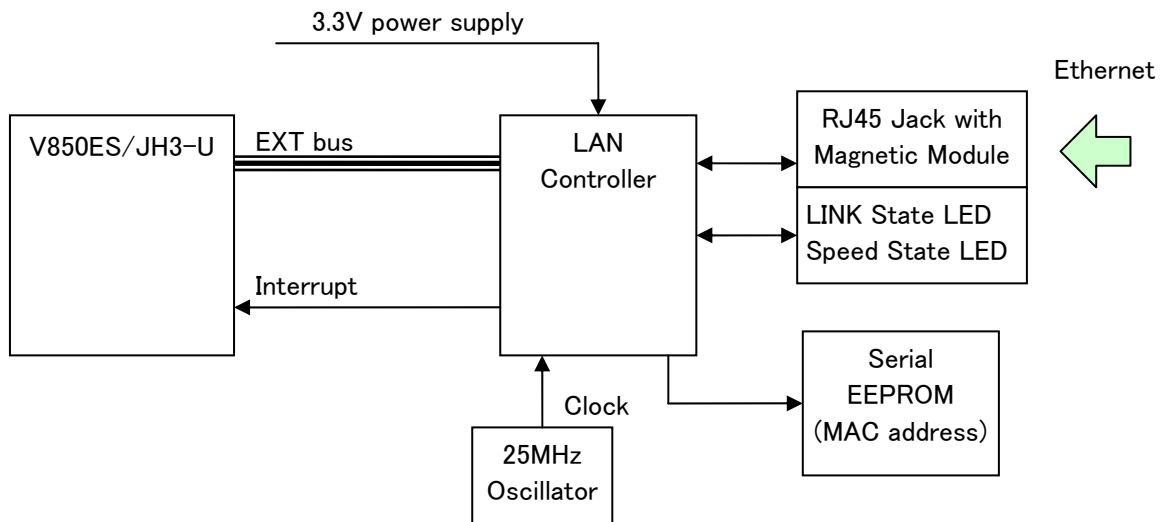

LAN controller pin	V850ES/JH3-U pin	V850ES/JH3-U Signal direction	Note
SA0~SA5	A1~A5	Out	
D0~D15	AD0~AD15	I/O	
nRD	_RD	Out	
nWE	_WR1	Out	
nCS	→		Connect to address decoder
nRESET	→		Connect to reset circuit
IRQ	P04/INTP03	In	Interrupt to CPU

### 3.5.5 Touch panel LCD (LCD version only)

- LCD panel CASIO COM50T5117GTC (5.0inch QVGA color)
- LCD controller Epson S1D13A05F00AB00B
- LCD controller register base address 0x600000
- LCD controller memory base address 0x680000

**Caution**

When you use LCD display, you must use power supply from AC adapter.

Touch Panel LCD block diagram

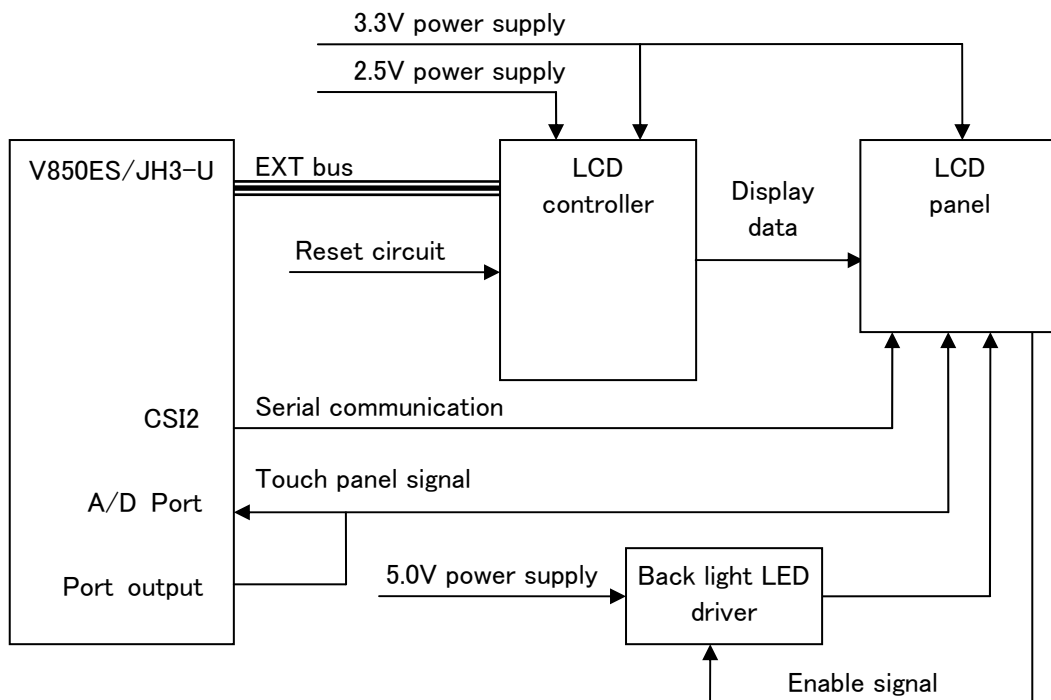

LCD controller

LCD controller pin	V850ES/JH3-U pin	V850ES/JH3-U Signal direction	Note
AB[17:1]	A1~A17	Out	
DB[15:0]	AD0~AD15	I/O	
CS#	→		Address decode
AB0	→		GND
M/R#	A19	Out	
CLKI	CLKOUT	Out	Bus clock
RD/WR#	_RD	Out	
RD#	_RD	Out	
WE0#	_WR0	Out	
WE1#	_WR1	Out	
WAIT#	_WAIT	In	
RESET#	→		Connect to reset circuit

## Touch panel LCD connection

LCD panel	V850ES/JH3-U pin	V850ES/JH3-U Signal direction	Note
YU	P97/SIF1/TIAA20/TOAA20/A7	OUT	Output port
XR	P96/TIAA21/TOAA21/INTP11/A6	OUT	Output port
YL	P71/ANI1	A/D in	A/D input
	P95/TIAA30/TOAA30/A5	OUT	Output port
XL	P70/ANI0	A/D in	A/D input
	P94/TIAA31/TOAA31/TENC00/EV TT00/A4	OUT	Output port
SCL	P23/_SCKF2/KR5/RTP05	CSI	LCD control
SI	P22/SOF2/KR4/RTP04	CSI	LCD control
/CS	P21/SIF2/TIAB00/KR3/TOAB00/R TP03	Out	LCD control
/RESET	→		Connect to reset circuit
BLON	→		Back light enable output

### 3.5.6 SRAM

- 1Mbyte (8Mbit) SRAM is installed.
- SRAM memory base address 0x100000

### 3.5.7 External bus interface

#### 1.1. External bus I/F devices

Device	Address pin	Accessing condition	Note
IrDA controller	A0-7	16bit access	The device is 8bit
LAN controller	SA0-5	16bit access	A1 is 2Byte pin
LCD controller	M/R, AB1-17	16bit access	AB1 is 2Byte pin
SRAM	A0-18	16bit access	1MByte

#### 1.2. Address mapping

- The address decoder assigns 4 devices to 010 0000H~01FFFFFFH (CS0 area)と 040 0000H~07FFFFFFH (CS2 area).

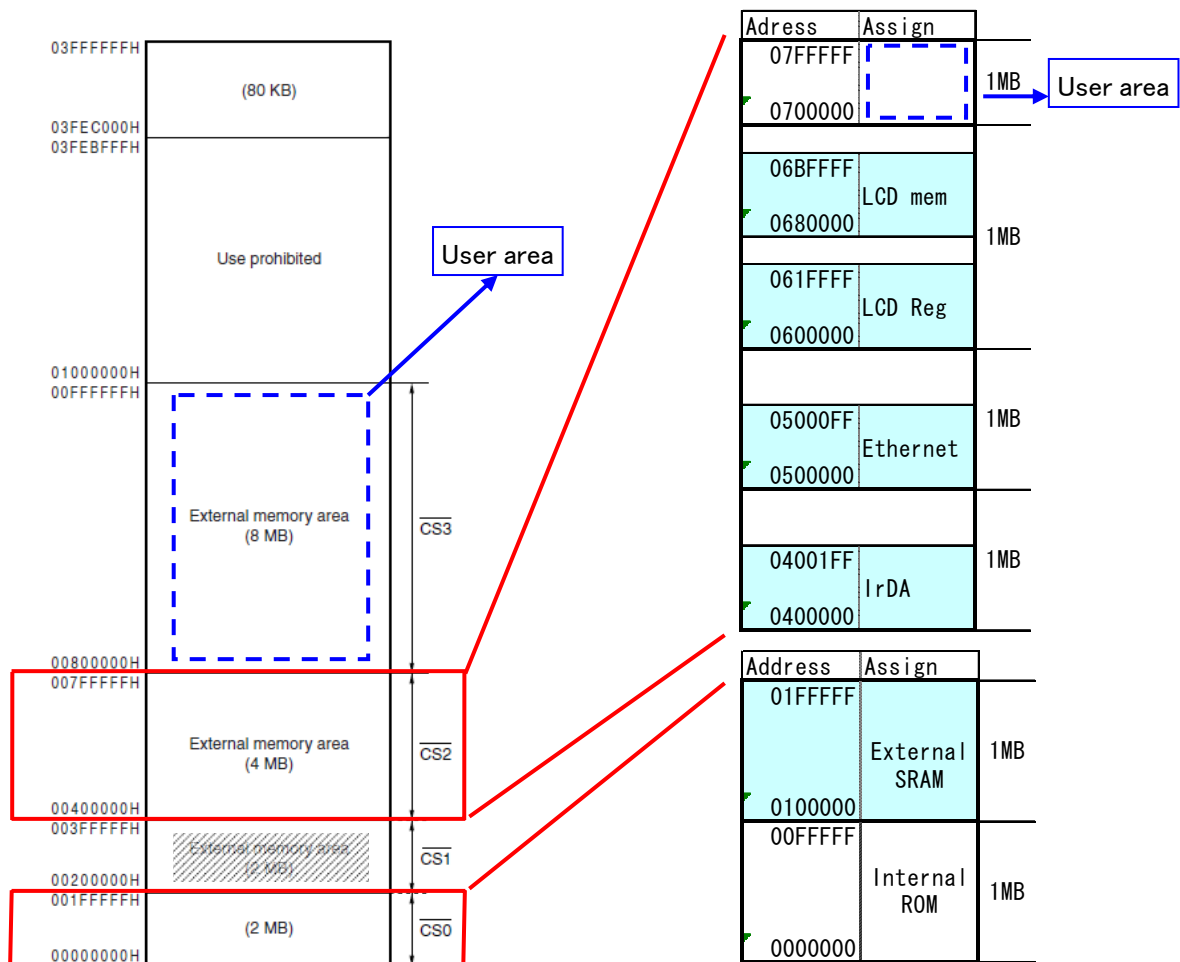

#### 1.3. External memory address area

- 070 0000H~07F FFFFH (CS2 area) 1MByte size
- 080 0000H~0FF FFFFH (CS3 area) 8MByte size

### 3.5.8 External connector

- You can connect external bus signals to external devices with external connector (CN1) (HIROSE FX8C-100P-SV4)

External connector block diagram

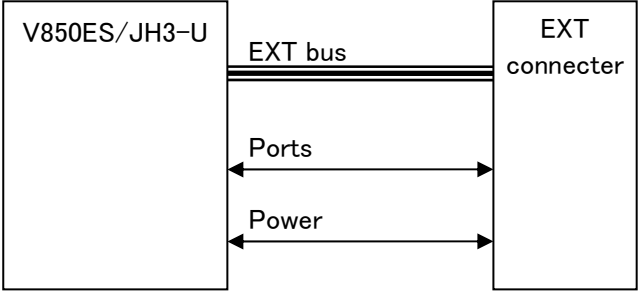

## External connector connections

No.	V850ES/JH3-U pin	Bus	No.	V850ES/JH3-U pin	Bus
1	A0	●	2	PCM3/HLDRQ	●
3	A1	●	4	P00/INTP00	
5	A2	●	6	P01/INTP01	
7	A3	●	8	P02/NMI	
9	A4	●	10	P11/ANO1	
11	A5	●	12	P20/TIAB03/KR2/TOAB03/RTP02	
13	A6	●	14	P24/INTP05	
15	A7	●	16	P25/INTP06	
17	A8	●	18	P32/ASCKC0/SCKF4/TIAA00/TOAA00	
19	A9	●	20	P33/TIAA01/TOAA01/RTCDIV/RTCGL	
21	A10	●	22	P36/TXDC3/SCL00/UDMARQ0	
23	A11	●	24	P37/RXDC3/SDA00/UDMAAK0	
25	A12	●	26	P40/SIF0/TXDC4/SDA01	
27	A13	●	28	P50/TIAB01/KR0/TOAB01/RTP00/UDMARQ1	
29	A14	●	30	P51/TIAB02/KR1/TOAB02/RTP01/UDMAAK1	
31	A15	●	32	P60/TOAB1T1/TIAB11/TOAB11	
33	PCM0/WAIT	●	34	P61/TOAB1B1/TIAB10/TOAB10	
35	PCM1/CLKOUT	●	36	P62/TOAB1T2/TIAB12/TOAB12	
37	CS_USER <sub>n</sub>	●	38	P63/TOAB1B2/TRGAB1	
39	PCS2/CS2	●	40	P64/TOAB1T3/TIAB13/TOAB13	
41	PCS3/CS3	●	42	P65/TOAB1B3/EVTB1	
43	PCT0/WR0	●	44	P74/ANI4	
45	PCT1/WR1	●	46	P75/ANI5	
47	PCT4/RD	●	48	P76/ANI6	
49	PCT6/ASTB	●	50	P77/ANI7	
51	PDH0/A16	●	52	P90/KR6/TXDC1/SDA02/A0	
53	PDH1/A17	●	54	P91/KR7/RXDC1/SCL02/A1	
55	PDH2/A18	●	56	P92/TENC01/TIT01/TOT01/A2	
57	PDH3/A19	●	58	P93/TECR0/TIT00/TOT00/A3	
59	PDH4/A20	●	60	P94/TIAA31/TOAA31/TENC00/EVTT00/A4	
61	PDH5/A21	●	62	P95/TIAA30/TOAA30/A5	
63	PDH6/A22	●	64	P96/TIAA21/TOAA21/INTP11/A6	
65	PDH7/A23	●	66	P97/SIF1/TIAA20/TOAA20/A7	
67	PDL0/AD0	●	68	P914/TIAA51/TOAA51/INTP17/A14	
69	PDL1/AD1	●	70	P915/TIAA50/TOAA50/INTP18/A15	
71	PDL2/AD2	●	72	RESET	
73	PDL3/AD3	●	74	AGND	
75	PDL4/AD4	●	76	3.3V Analog (AVDD)	
77	PDL5/AD5/FLMD1	●	78	3.3VDigital (VDD3.3)	
79	PDL6/AD6	●	80	3.3VDigital (VDD3.3)	
81	PDL7/AD7	●	82	3.3VDigital (VDD3.3)	
83	PDL8/AD8	●	84	GND	
85	PDL9/AD9	●	86	GND	
87	PDL10/AD10	●	88	GND	
89	PDL11/AD11	●	90	GND	
91	PDL12/AD12	●	92	GND	
93	PDL13/AD13	●	94	VDD5V (VDD)	
95	PDL14/AD14	●	96	VDD5V (VDD)	
97	PDL15/AD15	●	98	VDD5V (VDD)	
99	PCM2/HLDAK	●	100	VDD5V (VDD)	

### 3.5.9 Audio input

- You can capture analogue audio signal with the V850ES/JH3-U internal A/D converter.
- Monaural microphone level input.  
(Set the JP1 to short when you connect electret condenser microphone.)
- $\phi$  3.5mm Monaural mini plug input
- Anti-aliasing filter  $F_c = 3.6\text{kHz}$
- Filter structure = Three 2nd order low pass filters ( $-36\text{dB/oct}$ )
- Variable gain amplifier Micro Chip MCP6S91

Audio input block diagram

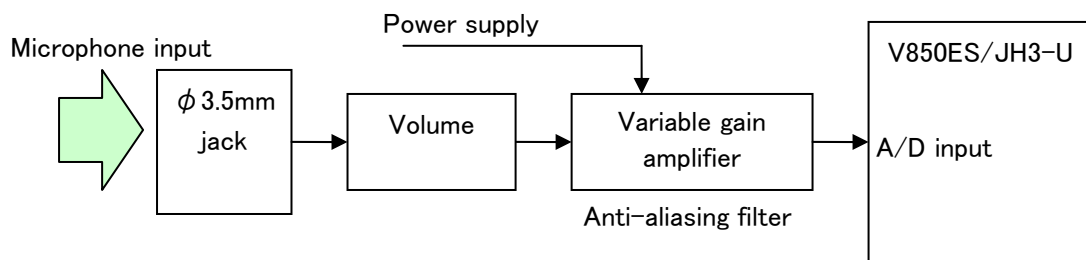

Connector pin	V850ES/JH3-U pin	V850ES/JH3-U signal direction	Note
Audio Input	P72/ANI2	A/D input	Preamp, filter, variable gain amp passed.

Variable gain amplifier connection

Pin	V850ES/JH3-U pin	V850ES/JH3-U signal direction	Note
CS	P40/SIF0/TXDC4/SDA01	Out	Chip select
SI	P22/SOF2/KR4/RTP04	Out	
SCK	P23/_SCKF2/KR5/RTP05	Out	

### 3.5.10 Audio output

- Monaural line level output. (Speaker drive acceptable)
- You can output analogue audio signal with the V850ES/JH3-U internal D/A converter.
- Anti-aliasing filter  $F_c = 3.6\text{kHz}$
- Filter structure = Three 2nd order low pass filters (-36dB/oct)
- $\phi 3.5\text{mm}$  Monaural/stereo mini plug output
- Amplifier With volume control National Semiconductor LM4865M

Audio output block diagram

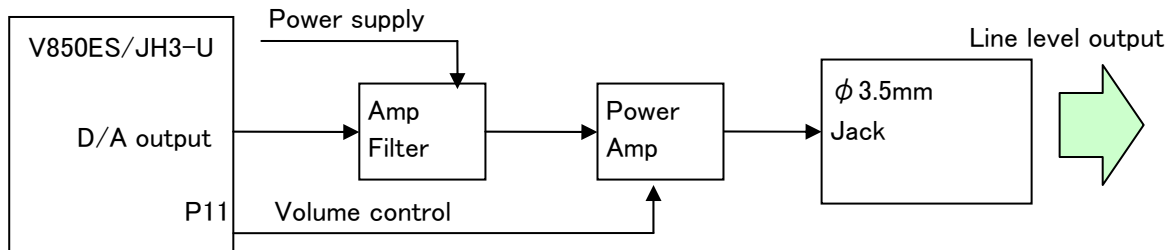

Connector pin	V850ES/JH3-U pin	V850ES/JH3-U signal direction	Note
Audio Output	P10/ANO0	D/A output	Output to filter circuit

Power amplifier connection

Pin	V850ES/JH3-U pin	V850ES/JH3-U signal direction	Note
DC Vol	P11/ANO1	D/A output	Volume control

### 3.5.11 RS-232C

- DSUB1 is the RS-232C serial communication connector
- You can cut the RS-232C driver output by cutting the solder short pad (TXDC1、RXDC1) for using the 3.3V level UART communication with external connector
- RS-232C driver IC MAX3232
- Connector D-sub 9Pin plug

RS-232C block diagram

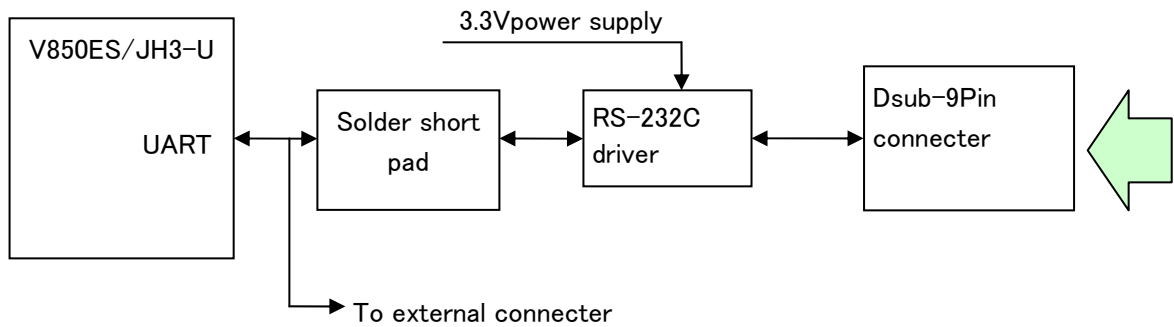

Driver IC	V850ES/JH3-U pin	V850ES/JH3-U signal direction	Note
TXD	P90/KR6/TXDC1/SDA02/A0	Out	UARTC1
RXD	P91/KR7/RXDC1/SCL02/A1	In	UARTC1

RS-232C connector pin connection (D-sub 9Pin plug)

1pin	N.C.	6pin	Connected to Pin4 (* 1)
2pin	RXD	7pin	Connected to Pin8 (*2)
3pin	TXD	8pin	Connected to Pin7 (*2)
4pin	Connected to Pin6 (* 1)	9pin	N.C.
5pin	GND	Shell	N.C.

\*1: You can cut the signal connection by cutting the solder short pad "P2".

\*2: You can cut the signal connection by cutting the solder short pad "P1".

## CHAPTER 4 Troubleshooting

This chapter describes how to solve troubles you may face.

### 4.1 If you cannot find USB driver when you connect PC to the kit

#### Check Point 1

If you use USB hub, do not use it. (USB hub is not supported)

#### Check Point 2

Check if you installed "NEC Electronics Starter Kit Virtual UART Driver" in "[1.4 Installation of USB Driver](#)". If not, install the driver.

#### Check Point 3

If above 2 check points are confirmed, disconnect the USB cable from PC and re-connect again.

### 4.2 Error when you start the debugger

There could be several reasons to make errors happen.

The solving processes differ depending on errors. Please check the error message first.

The solving processes for each error are as follows.

#### 4.2.1 "Can not communicate with Emulator..." (F0100 or A0109)

##### Check Point 1

If you use USB hub, do not use it. (USB hub is not supported)

##### Check Point 2

Check if the settings of switches on the kit are correct with referring "[2.7 Check Board Settings](#)".

##### Check Point 3

Confirm the USB driver installation with referring to "[1.4 Installation of USB Driver](#)".

##### Check Point 4

If above 3 check points are confirmed, close the debugger and disconnect the USB cable from PC. Re-connect USB cable properly to both the PC and the kit, and then re-start the debugger.

## 4.2.2 "Incorrect ID Code." (Ff603)

This error occurs when the security ID stored on microcontroller built-in flash memory is different from the ID code you entered at the start of debugger.

Security ID entry area at the start of debugger



### Check Point 1

Enter correct security ID and click OK on the configuration window.

### Check Point 2

If you forgot the security ID, you have to erase the microcontroller built-in flash memory. Before erasing, check if you actually set the security ID with referring to "[2.5 Set Options](#)". Also remember the code you set for the security ID.

After this, erase the flash memory with referring to "[5.4 WriteEZ1](#)".

## 4.3 Monitor memory cannot be accessed. (F0c72)

### Check Point 1

Check if the settings of switches on the kit are correct with referring "[2.7 Check Board Settings](#)".

### Check Point 2

Erase the flash memory with referring to "[5.4 WriteEZ1](#)".

### Check Point 3

If above 2 check points are confirmed, disconnect the USB cable from PC and re-connect again. And, retry starting the debugger.

## CHAPTER 5 Other Information

This chapter explains some useful operation techniques of development tools and circuit diagram of the kit for developing of user programs.

[5.1 Create a new workspace \(project\)](#)

[5.2 Register additional source file](#)

[5.3 Debugger tips](#)

[5.4 WriteEZ1](#)

[5.5 Circuit diagram](#)

## 5.1 Create a new workspace

Now, create a new workspace and project.

PM+ allows you to create a new workspace with following "New WorkSpace" dialog.

Select "File" on PM+ menu bar, then "New Workspace...".

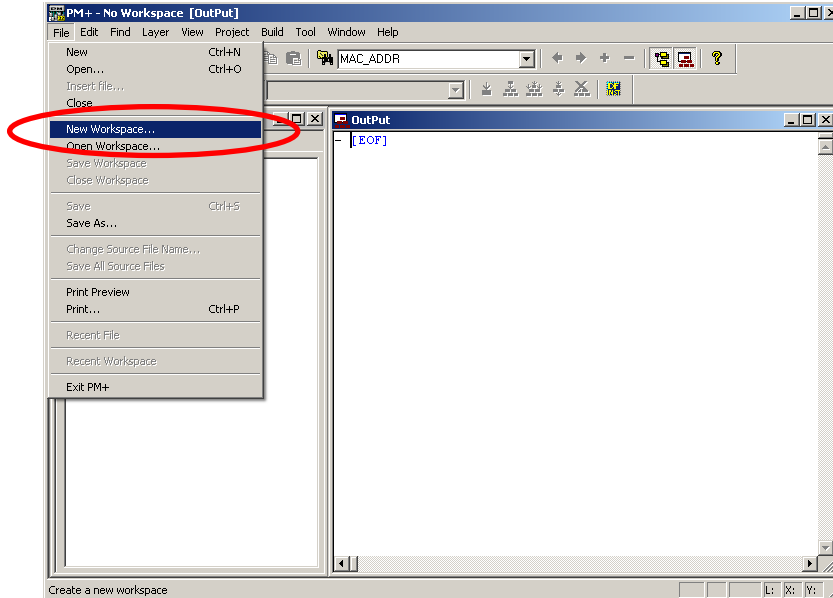

"New WorkSpace" dialog opens



<Description of items>

**Workspace File Name:**  
 -> Specify the name of the workspace file that manages the project files.  
 .prw is automatically suffixed as the file type.  
 A project file (.prj) of the same name is simultaneously created.

**Folder:**  
 -> Specify the folder for saving the workspace file by writing its absolute path.  
 This item can be selected from a reference dialog box by pressing the **Browse...** button.

**Project Group Name:**  
 -> Specify this item if wishing to manage multiple projects together in function units.  
 If nothing is specified, this item is the same as the workspace file name.

**Microcontroller Name:**  
 -> Specify the name of the microcontroller to be used.

**Device Name:**  
 -> Specify the name of the device to be used.

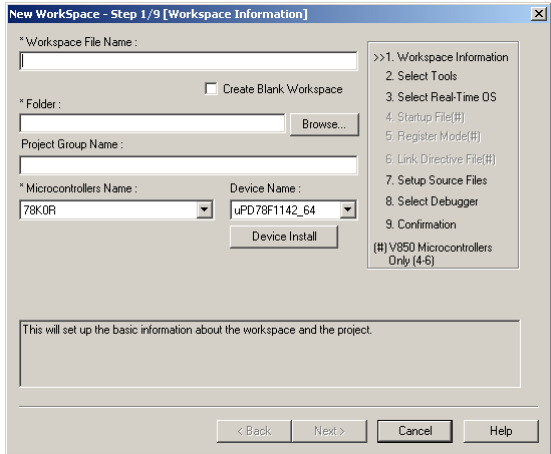

The concrete information set here is described on the following pages

Input the workspace information setting as follows.

Workspace file name

→ test

Folder

→ C:\TK850\test

Project Group Name

→ (no input)

Microcontroller Name

→ V850

Device Name

→ uPD70F3769

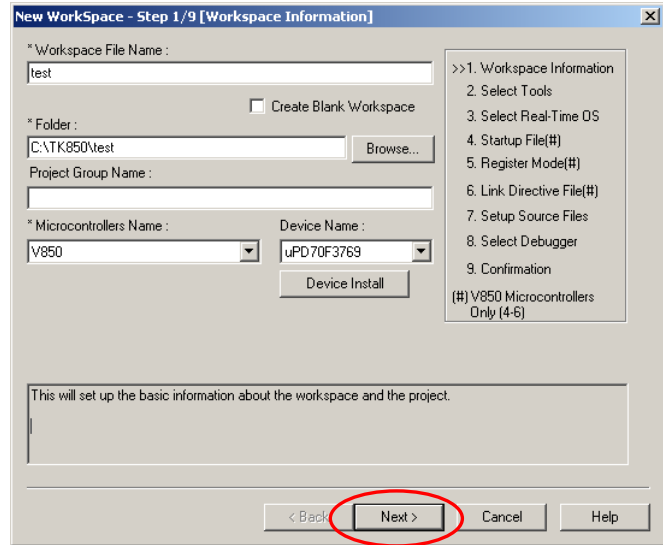

Click **Next >** button

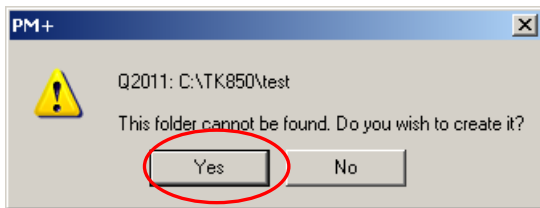

Click **Yes** button

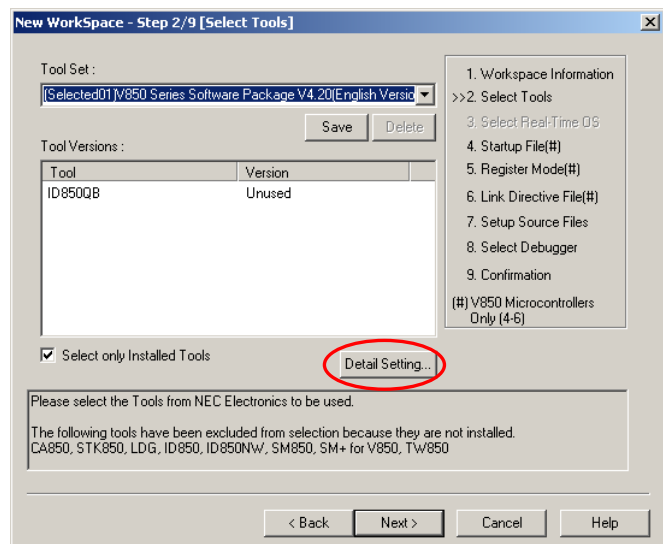

Click **Detail Setting** button

Set the version of tools as follows.  
 CA850: **W3.20**  
 ID850QB: **V3.50**

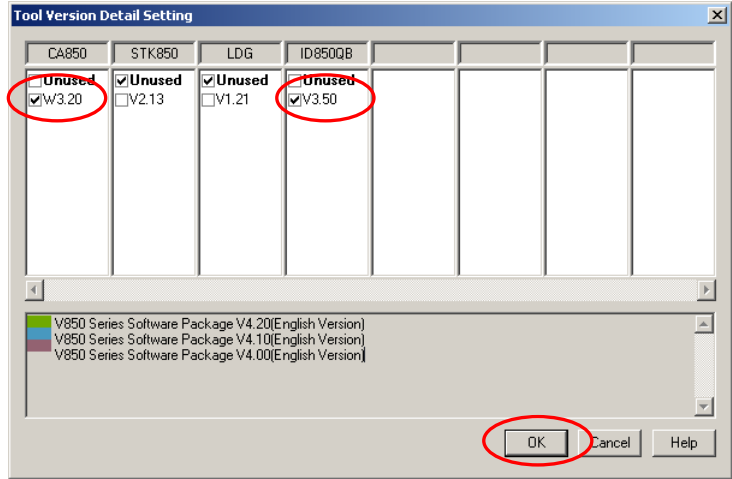

Select tools as above screenshot, then click **OK** .

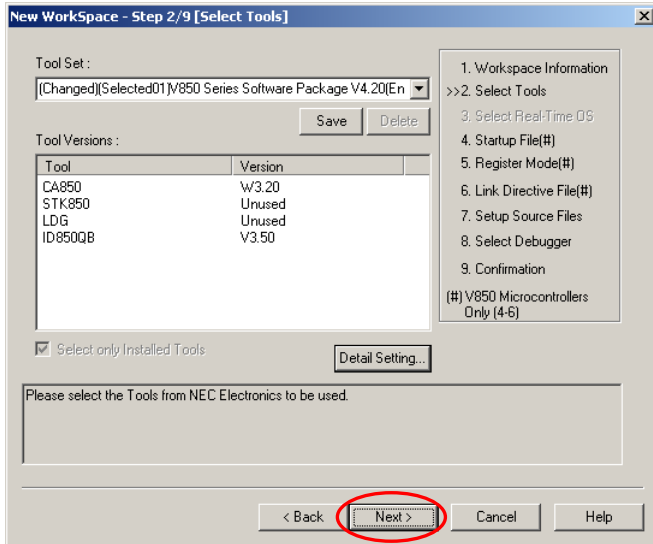

Click **Next >**



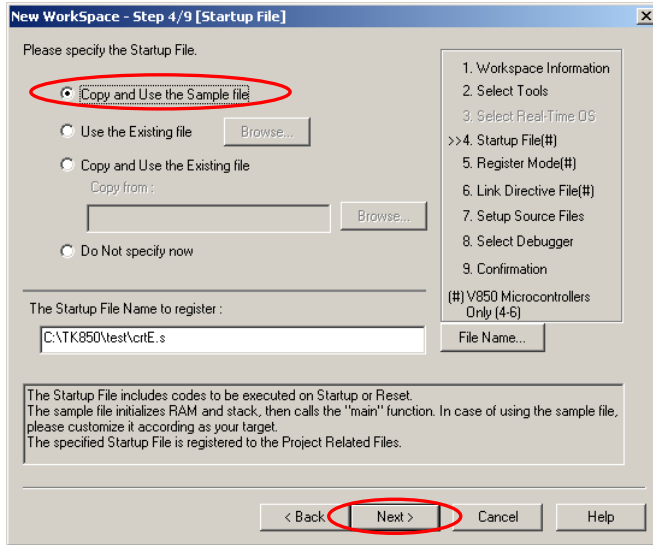

Select the "Copy and Use the Sample file".

Press the **Next >** button.

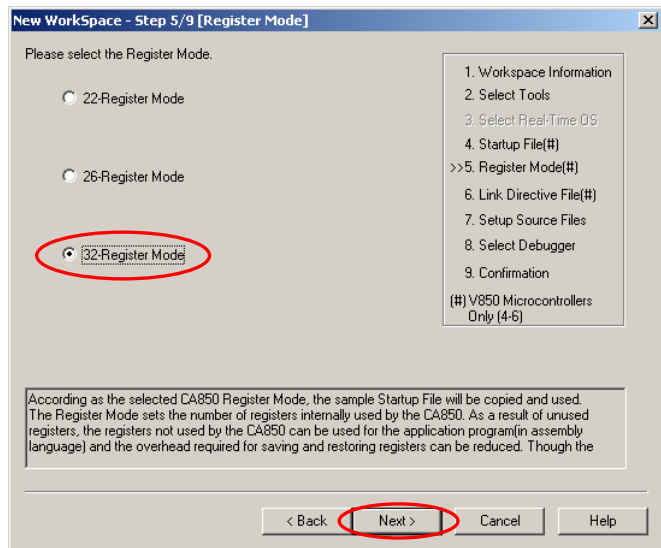

Select the "32-Register Mode".

Press the **Next >** button.

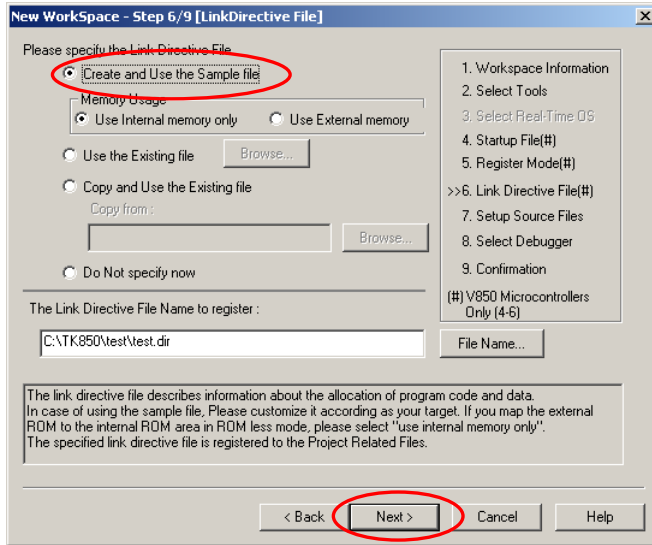

Select the "Create and Use the sample file"

Press the **Next >** button.

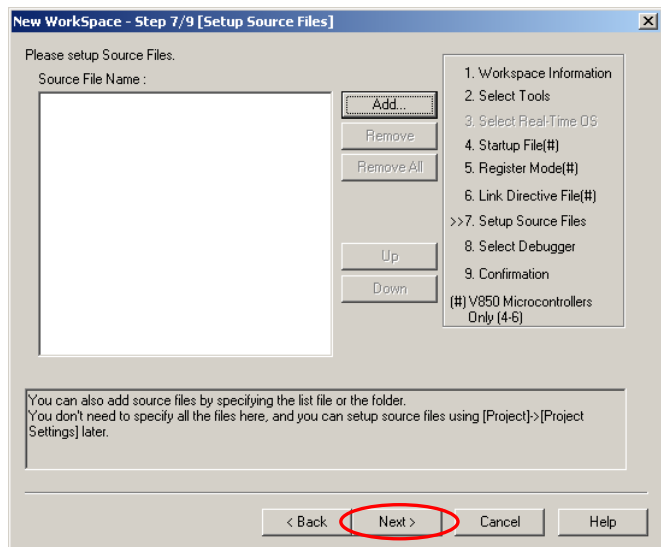

Press the **Next >** button.



Select the "ID850QB V3.50"

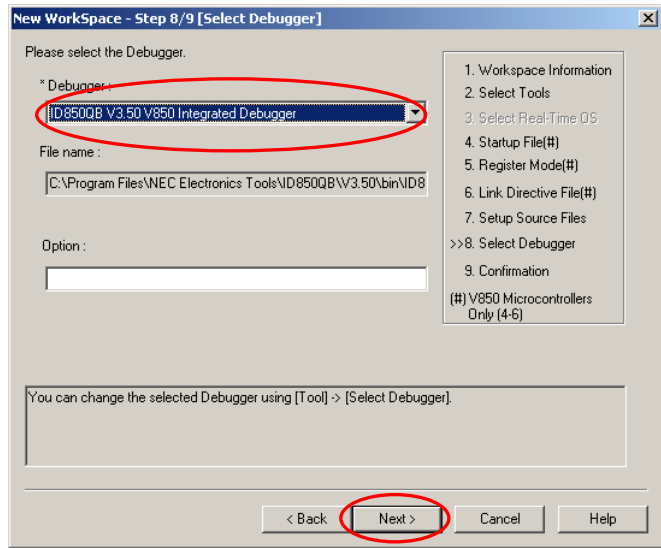

Press the **Next >** button.

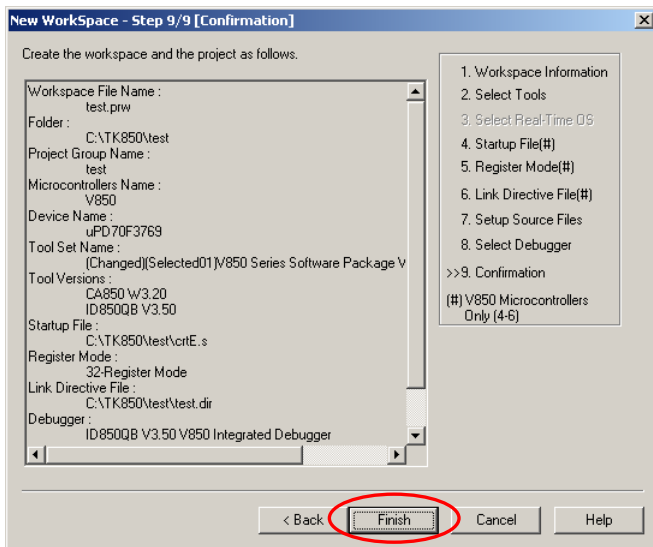

Press the **Finish** button.

Check the project information setting contents.



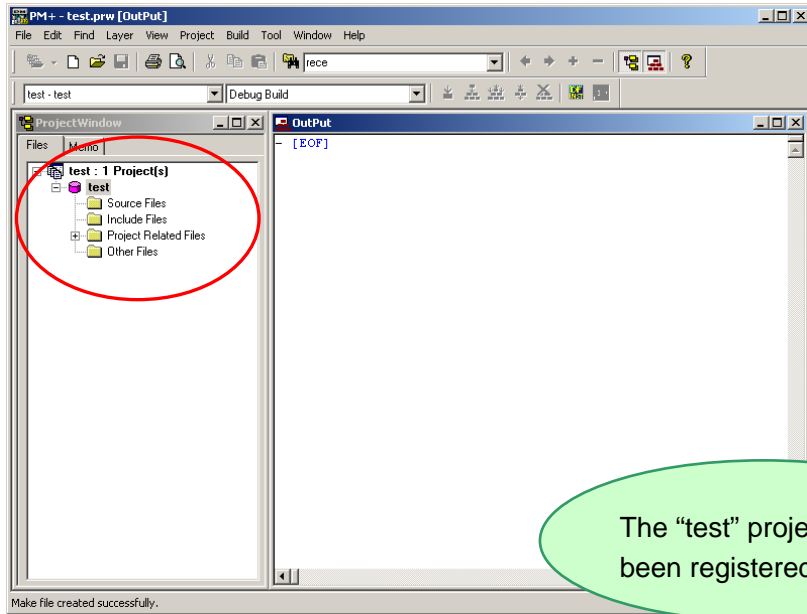

This completes workspace and project creation.

Additional source files can be registered at any time thereafter.

➡ For details, refer to ["Registering additional source files"](#).



Next, setup the security ID

In the PM +, [Tool] → [Compiler common Options...] is selected.

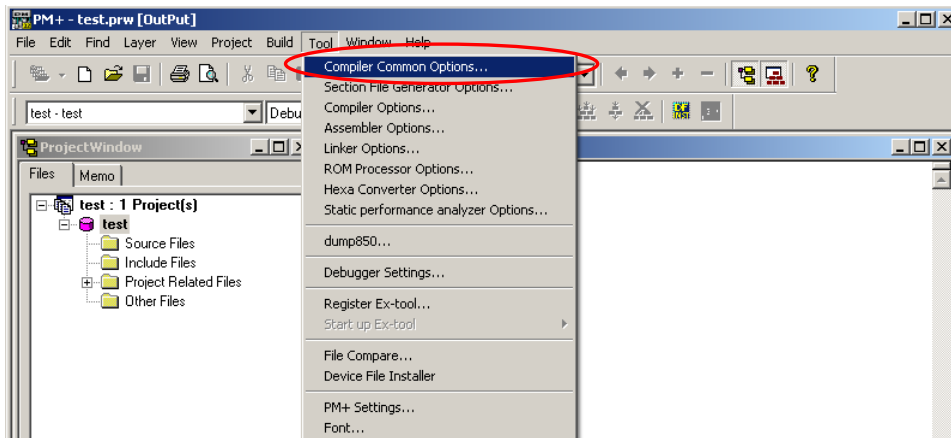

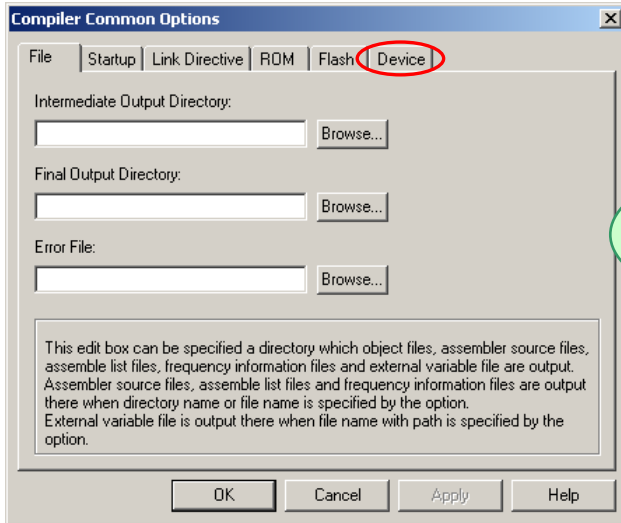

Compiler Common Options setting is open.

Click the "Device" tab.

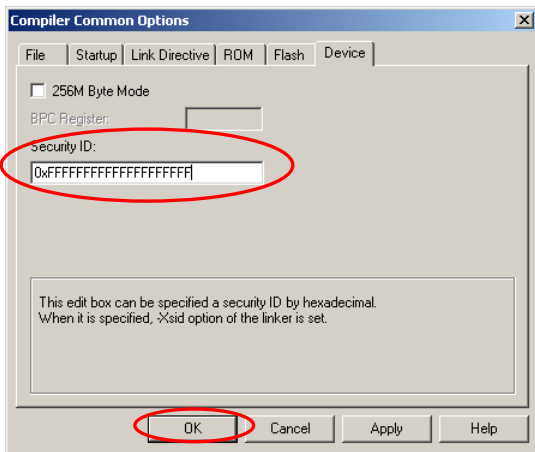

The actualities of "FFFFFFFFFFFFFFFF" (20 of F) are taken if there is no problem in the value of ID in security.

Press the **OK** button.

Security ID settings are complete

## 5.2 Register additional source file

Now, register additional source files.

The following example shows the additional registration of source files “b.c” and “c.c” with source file “a.c” already registered.

Place the cursor on the source file in the Project window of PM+, and select [Add Source Files...] displayed in the right-click menu.

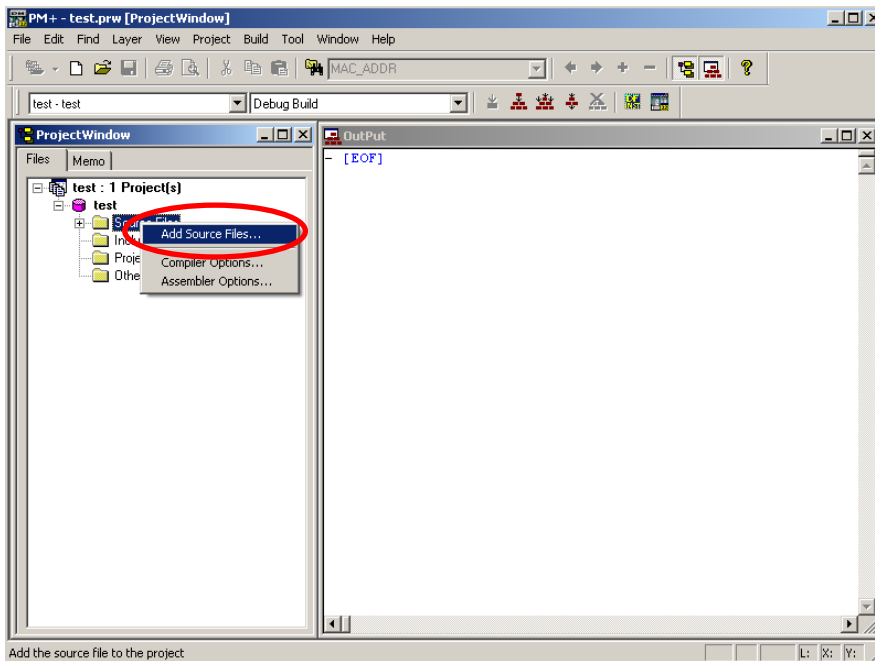

Select source files “b.c” and “c.c”, then click

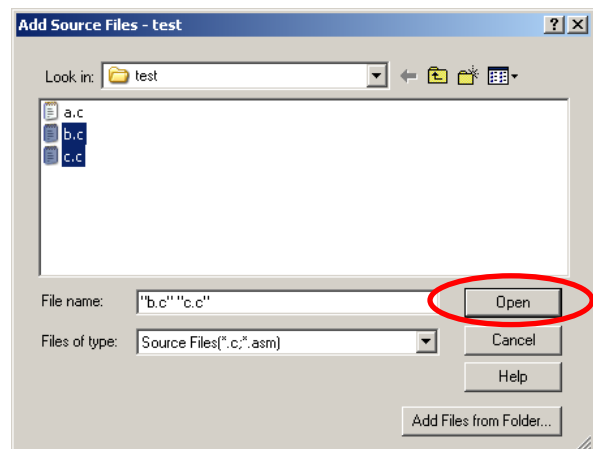

Multiple source files can be selected by clicking them with pressing  key.



Source file "b.c" and "c.c" are additionally registered to the project.

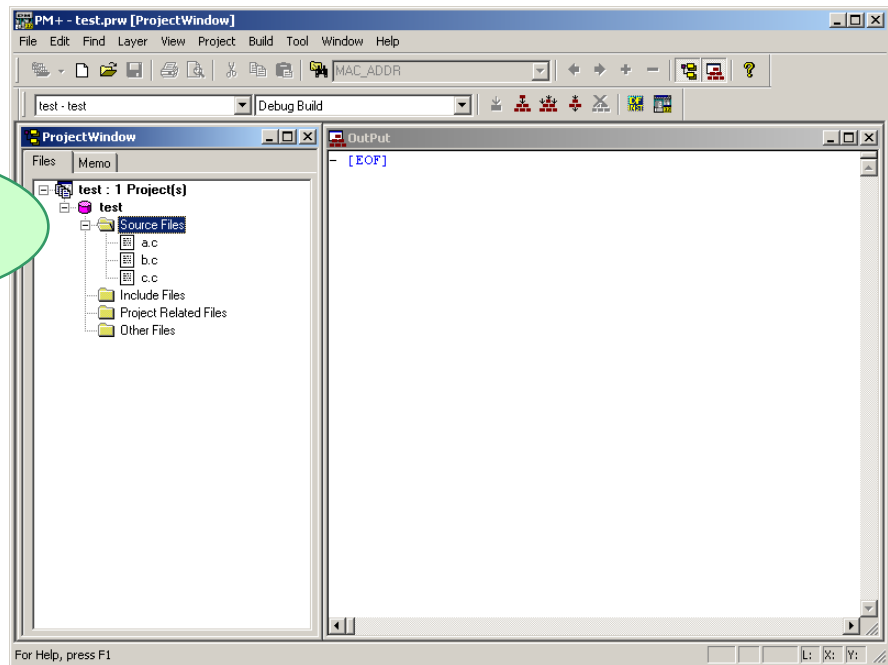

## 5.3 Debugger tips

This section describes some useful techniques for the debugger (ID850QB).

### 5.3.1 Change display of buttons

Execution controls (run, stop, step-in debugging, reset, etc) and opening functional window can be made by below buttons. However, it could be difficult to know which button does what.



In this case, select "Options" on menu bar, then "Debugger Options". Check "Pictures and Text" on setting area.



With this setting, the buttons display the text as well, so that it is easier to know what they are.



### 5.3.2 Display source list and function list

When you wish to see source file list or function list, select "Browse" on menu bar, then "Other" -> "List" to open the list window. The information in the windows is synchronized. Therefore, it is not just for referring to the list, but it is useful when you wish to update files or functions.

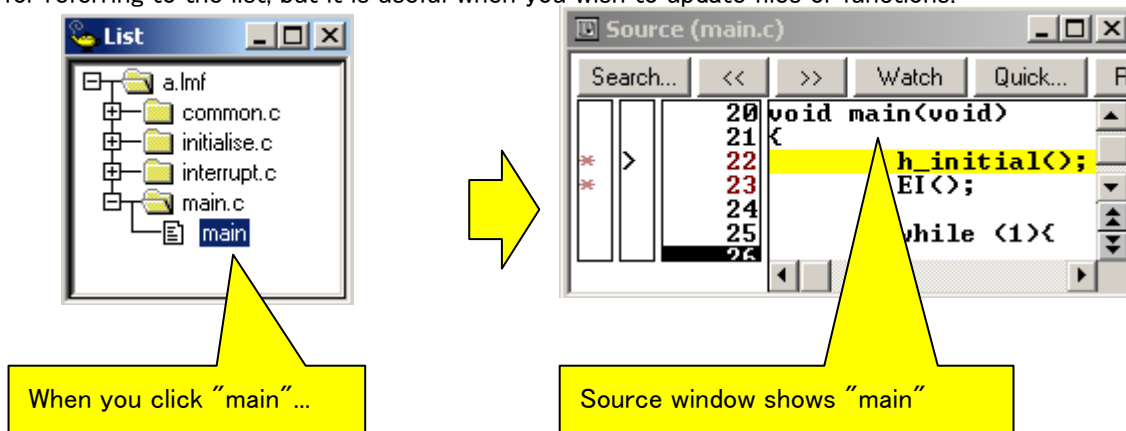

### 5.3.3 Set/delete breakpoints

Breakpoints are executed by clicking lines in which " \* " is displayed

"B" is displayed in the line where a breakpoint is set.

Breakpoints are deleted by clicking "B".

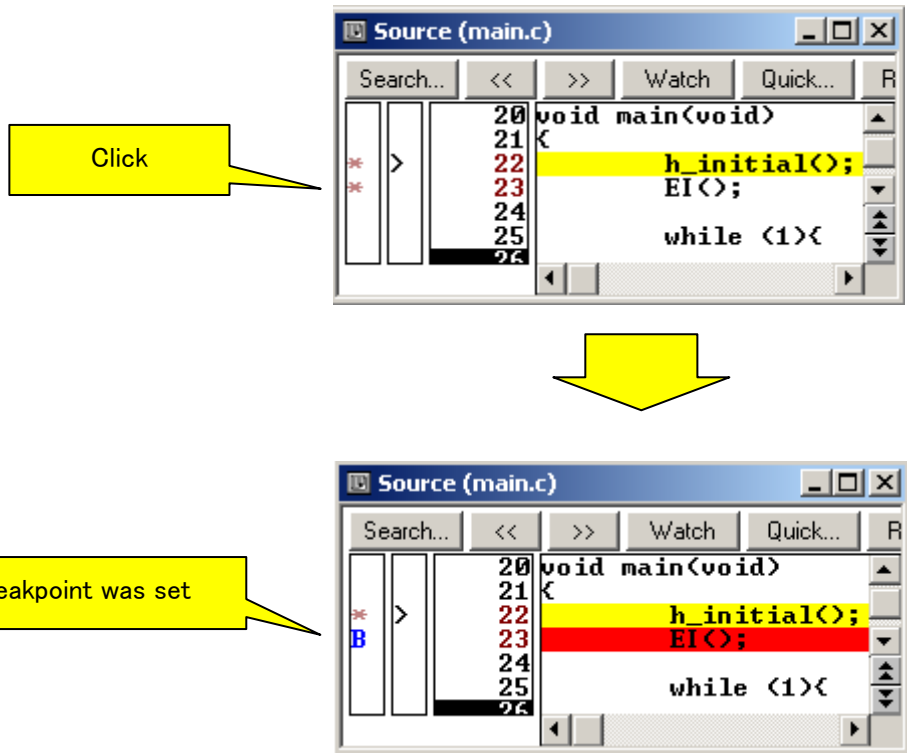

### 5.3.4 Display global variables

With using Watch Window, you can display global variables. There are several ways to register global variables to watch window. In this section, how to register from source window is described.

①Right-click the variable on source window, then select "Add Watch..."

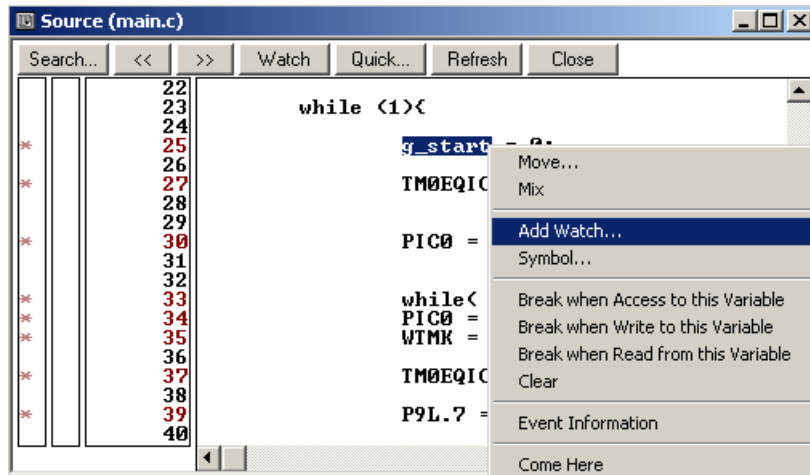

②Add Watch dialog opens. Click **OK** .

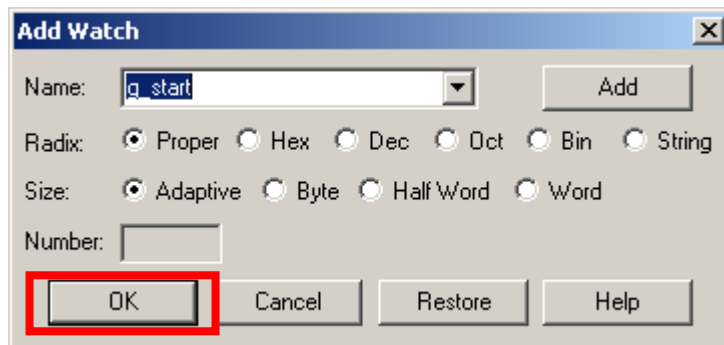

③Adding a variable to watch window is completed.

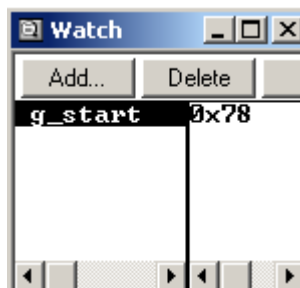

### 5.3.5 Display local variables

Local variable window is used to display local variables.

By clicking the button below, you can open the local variable window.

Unlike global variables, local variables cannot be displayed when programs are running.

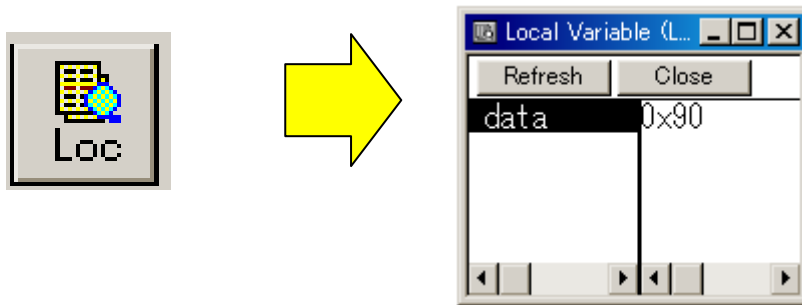

### 5.3.6 Display memory and SFR contents

By clicking the button below, you can open the memory window.

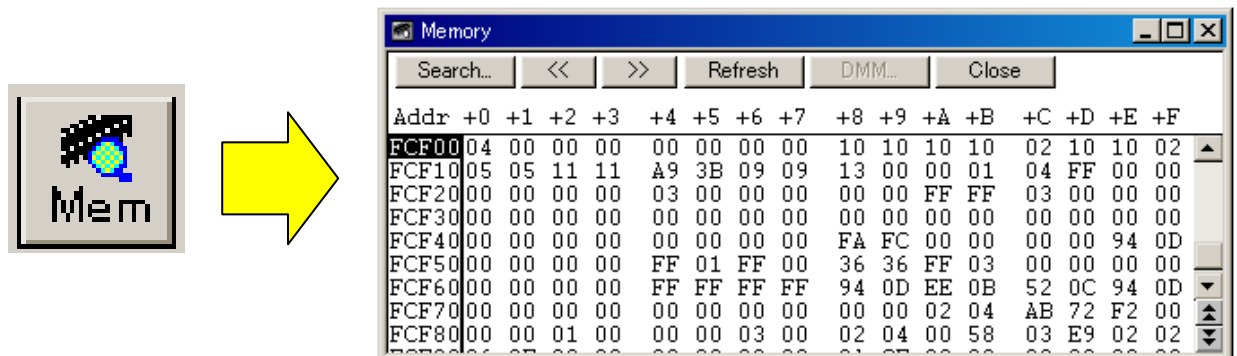

By clicking the button below, you can open the IOR window.

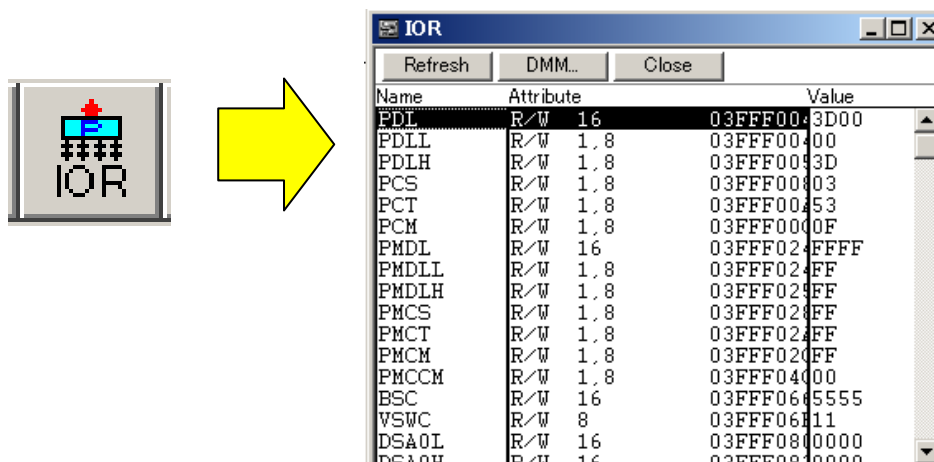

## 5.4 WriteEZ1

If you forgot the security ID or if you set On-Chip Debug Option Byte to disable the on-chip debug function, you cannot start debugger. In this case, you need to delete the setting values of security ID and On-Chip Debug Option Byte. Use WriteEZ1 to erase the flash memory.

WriteEZ1 cannot be installed from an integrated installer. Please execute  
¥WriteEZ1¥WriteEZ1.exe  
from attached CD.

The hardware for WriteEZ1 is incorporated in TK-850/JH3U-SP.

Down loaded program by ID850QB which is down load with monitor file for debugging is not run stand-alone.

The program written by WriteEZ1 which is not including the monitor file is able to run standalone.

- ① The switch of TK-850/JH3U-SP is set as follows, and connects TK-850/JH3U-SP to PC.

SW1

Bit1	OFF
Bit2	ON
Bit3	ON
Bit4	ON

- ② Please execute "¥WriteEZ1¥WriteEZ1.exe" from attached CD.

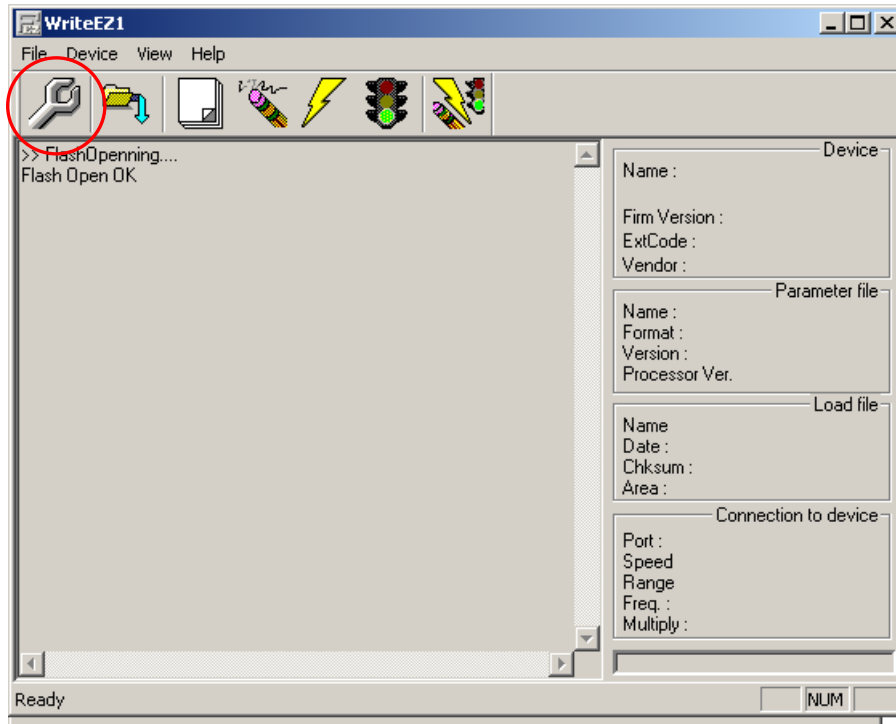

- ③ Push the 「Setup」 button.



- ④ Push the 「PRM File Read」 button.

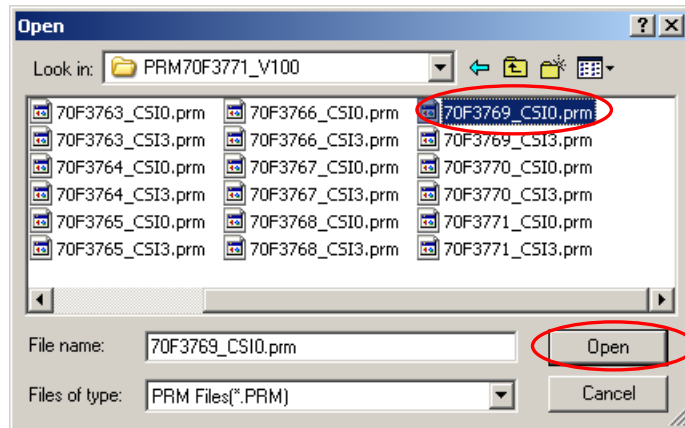

- ⑤ Please select “70F3769\_CSI0.prm” in the directory of “¥PRM¥PRM70F3771\_V100” in the CD-ROM.

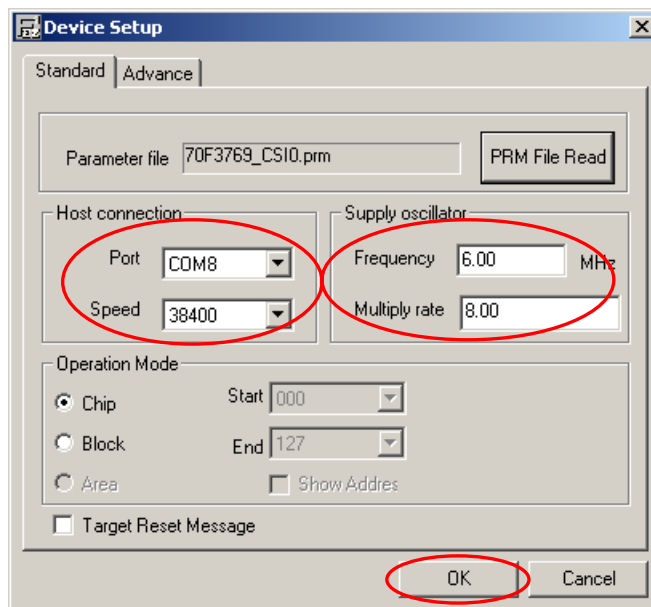

- ⑥ "Port" selects the COM port number where TK-850/JH3U-SP is allocated.  
※Only the COM port number that the personal computer has is displayed in this pull-down menu.  
Input “6.00” to “Frequency”  
Input “8.00” to “Multiply rate”  
Input “38400” to “Speed”, and click “OK”

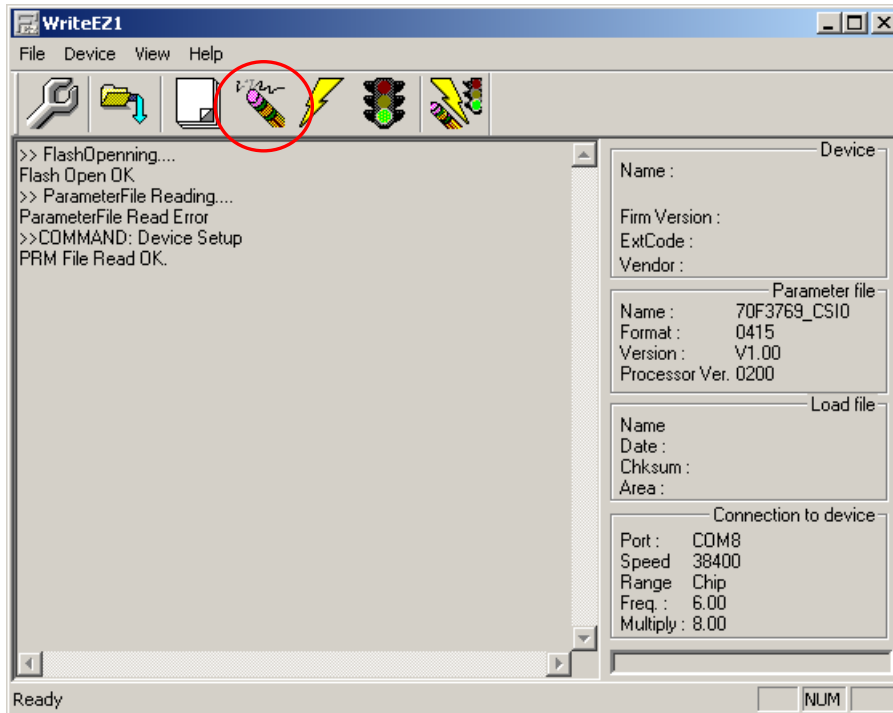

⑦ "Erase" The deletion of the flash memory begins when the button is pushed.

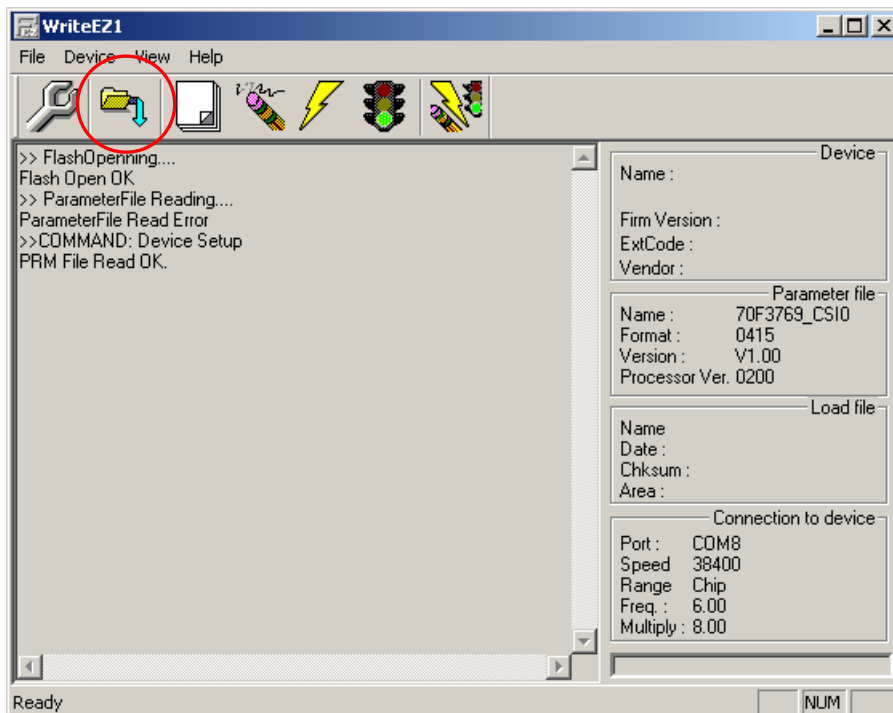

⑧ When you write the program, click "load" then select writing HEX file.

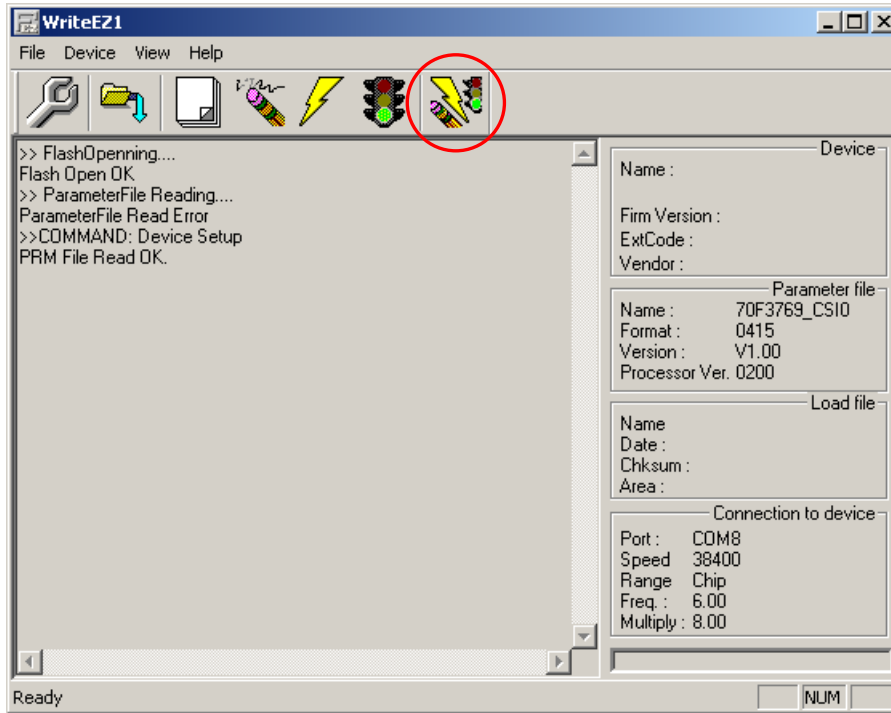

- ⑨ Hex file writing will be start by clicking “AutoProcedure” .

## 5.5 Circuit diagram

From following page, it shows the circuit diagram of the kit.



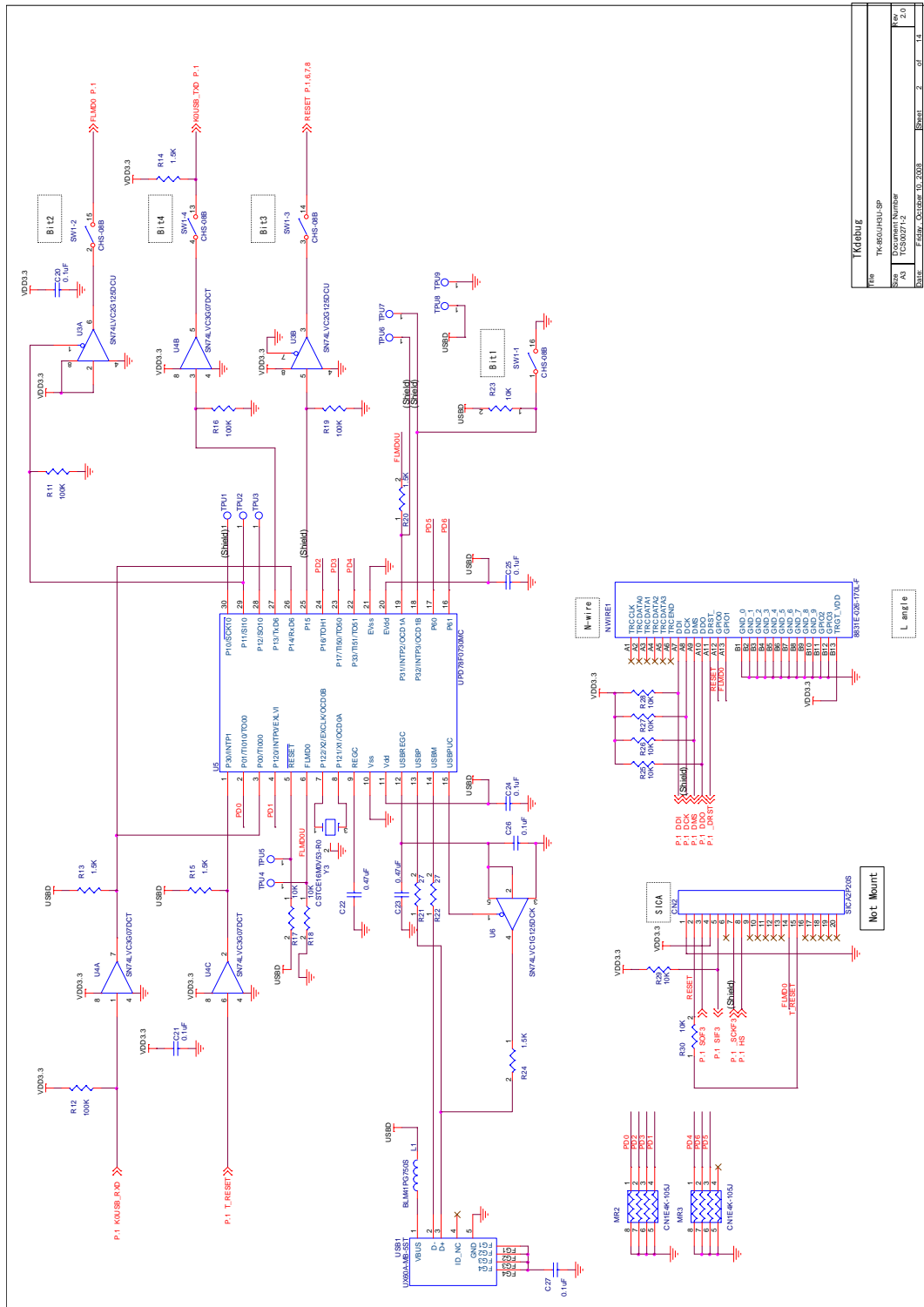

File	TK850JH3U.SP
Size	Doc sheet Number
AS	TK850JH3U-2
Date	Fri, 09 October 2009 10:20:00
Sheet	2 of 14

Tkdesign

L angle

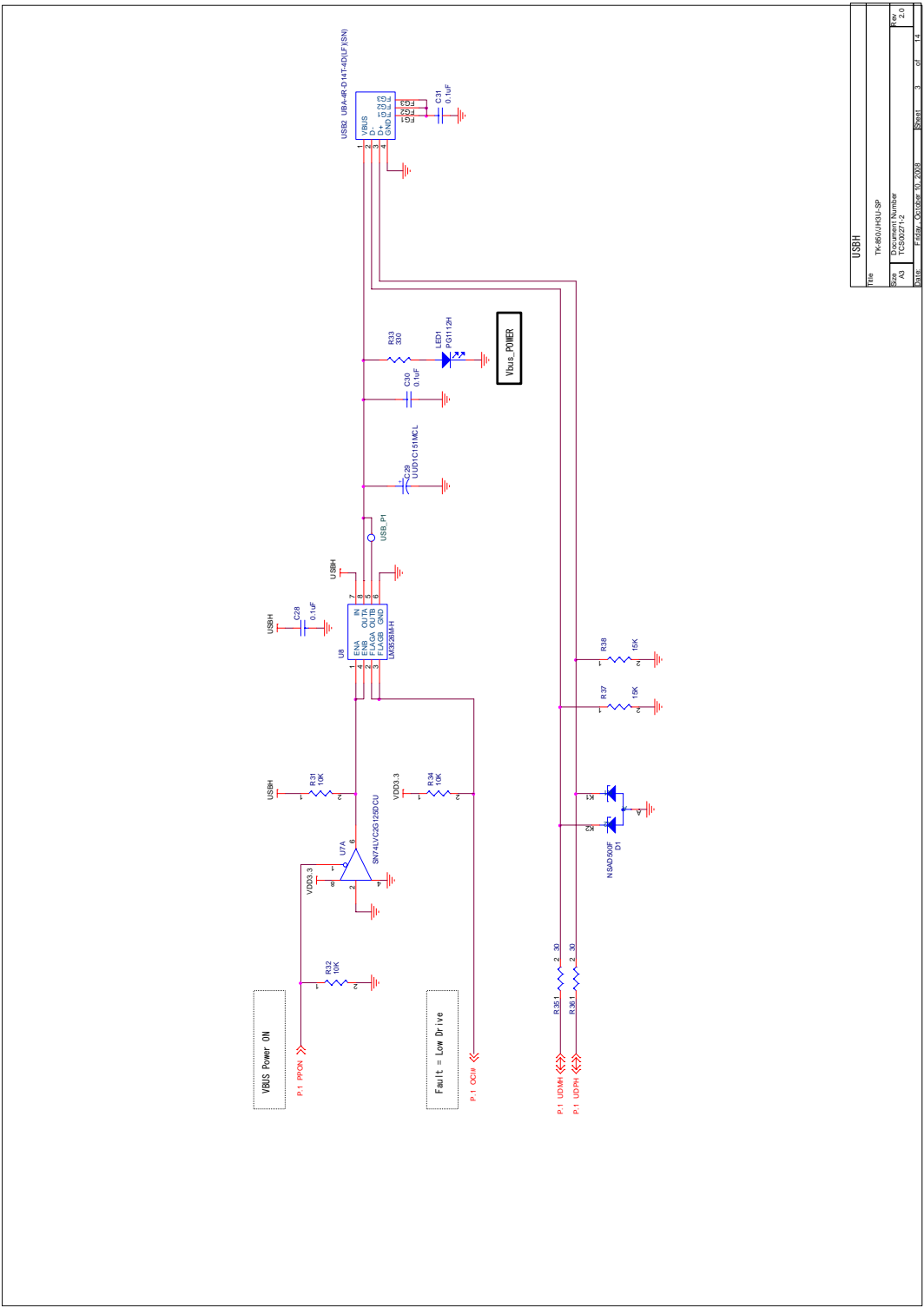

Title		USBH
Doc No.		TK-850/JH3U-SP
Doc. Version		1.0
Date		2008.10.20
Author		Y. Saito
Check		Y. Saito
Date		2008.10.20
Page		3 / 14

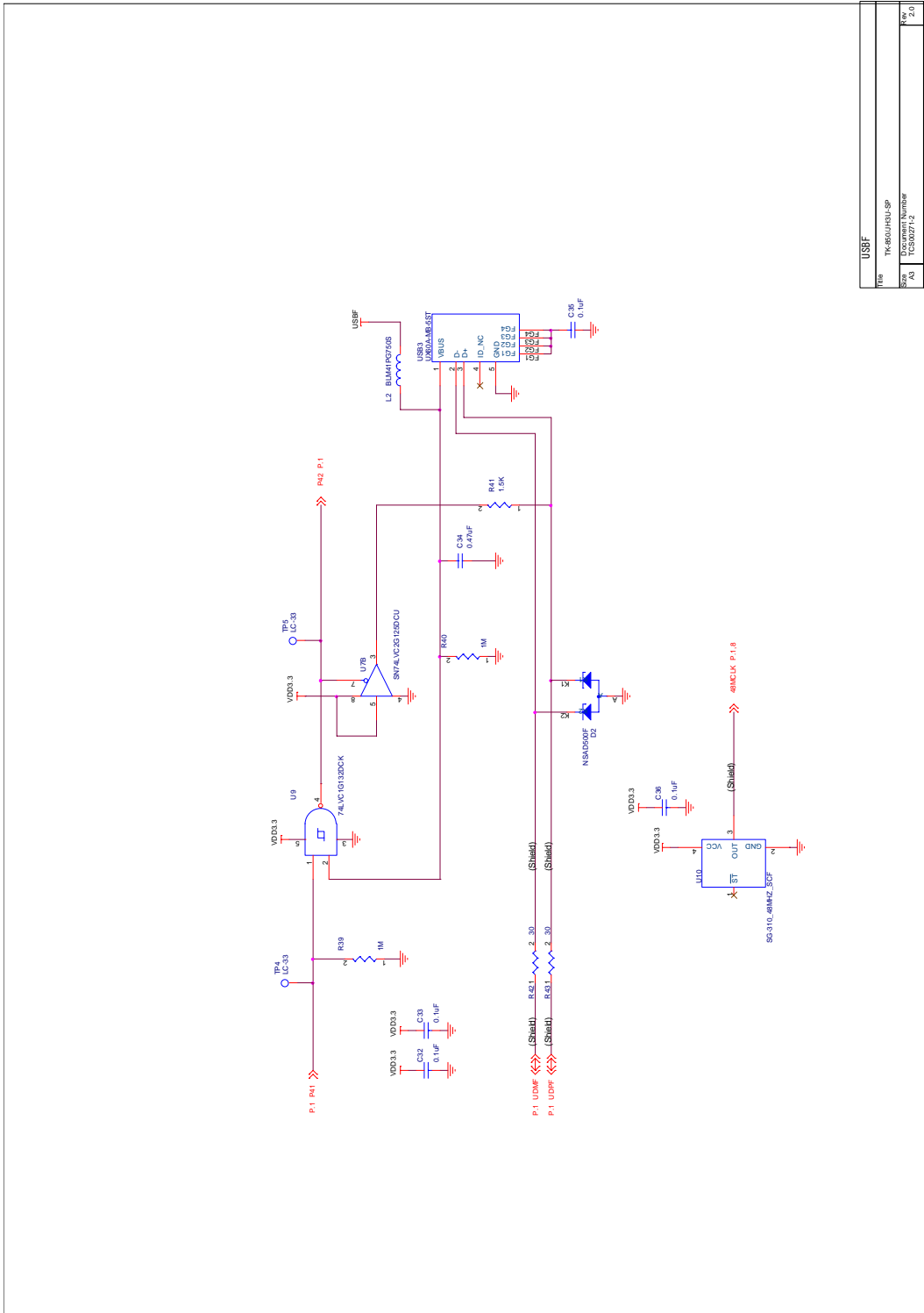

USB	
File	TK-850/JH3U-SP
Size	Document Number
AD	TC100271-2
Rev	2.0
Date	February, October 10, 2010
Sheet	4 of 14



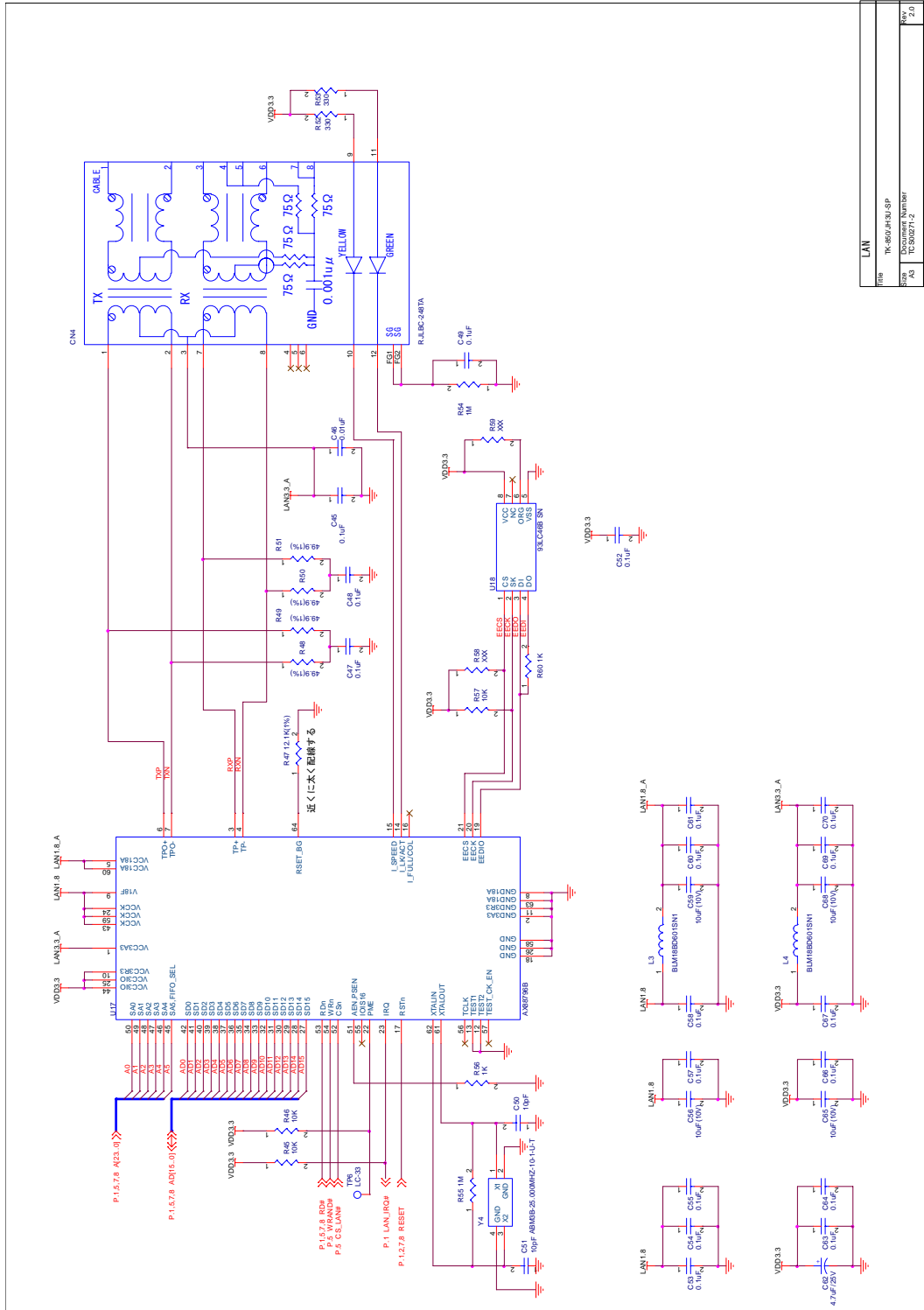

File	LAN
Rev	TK-850/JH3U-SP
Docu. No.	Docu. Number
Ver	Ver. No.
Date	Date
Drawn	Drawn
Checked	Checked
Rev	Rev
2.0	2.0
0	0
14	14









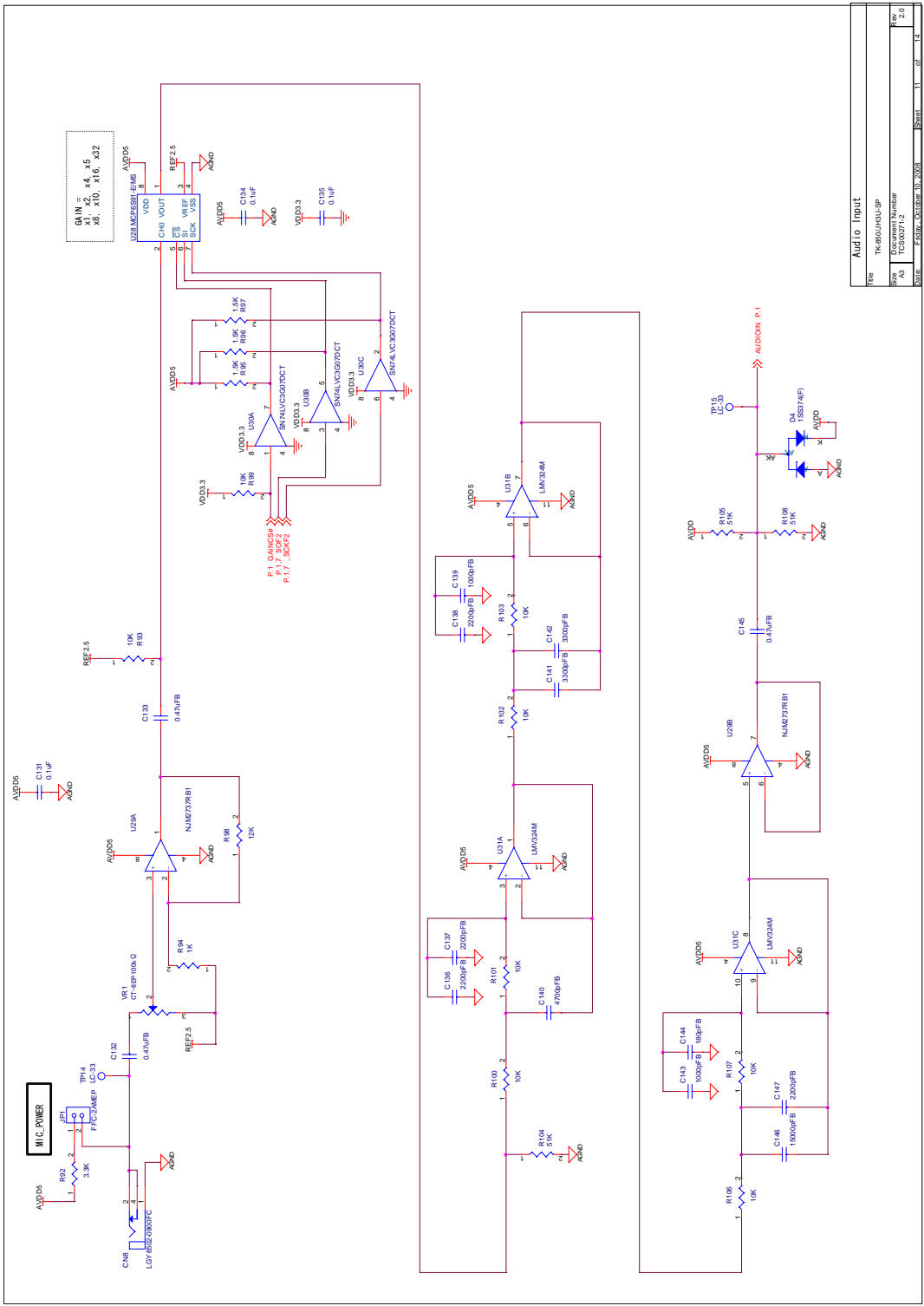

Audio Input	
File	TK-850/JH3U-SP
Sheet	1 of 2
Doc. Number	TK-850/JH3U-SP
Rev.	1.0
Date	2008.10.20
Sheet	11 of 14

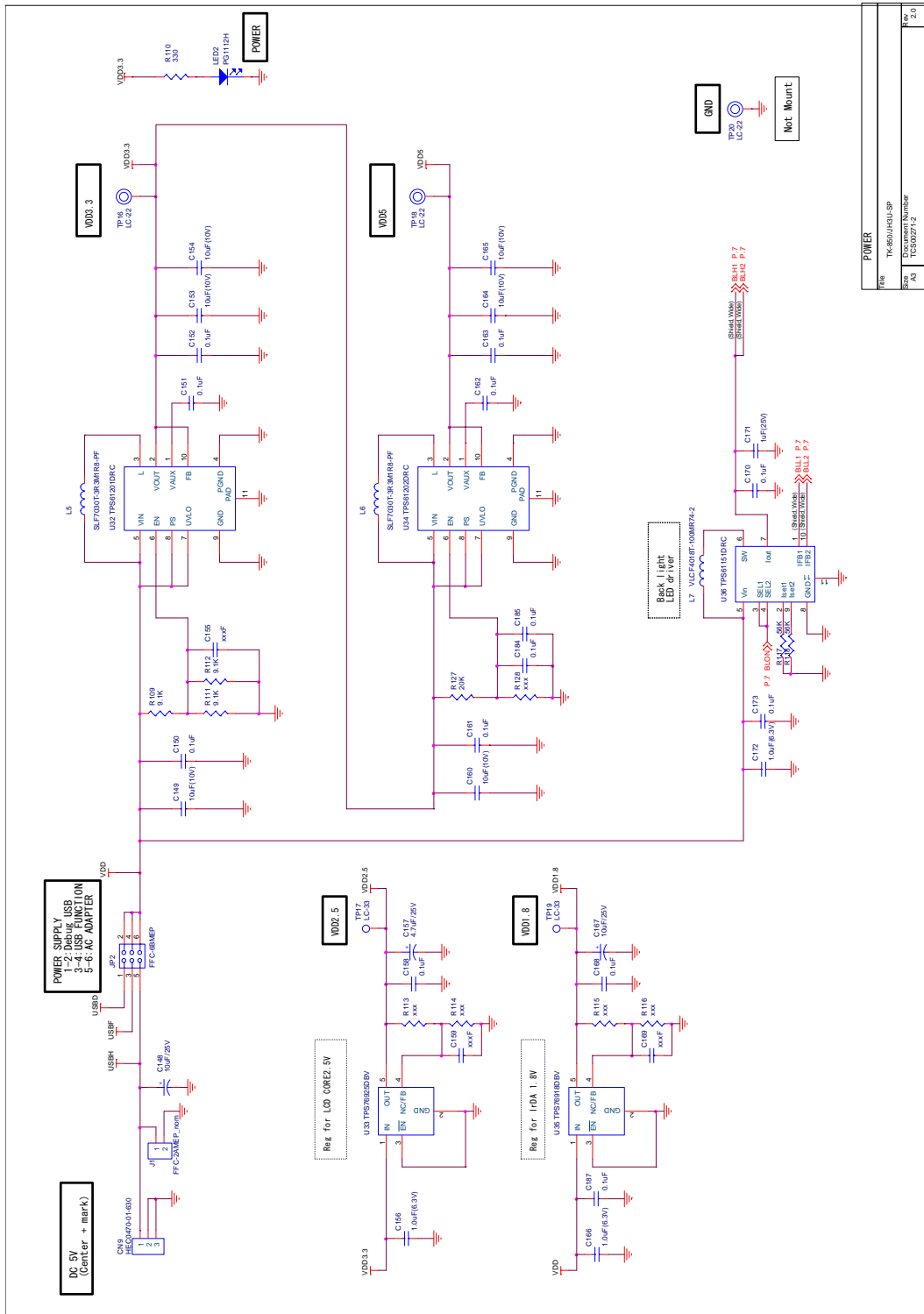

POWER			
File	TK-850/JH3U-SP	Sheet	12 of 14
Size	Document Number	Rev	2.0
Adj	TC830021-2	Date	FEB 27, OCTOBER 10, 2010

