

TK-850/KJ2

Hardware Manual

2008/6 The 2nd edition
TESSERA TECHNOLOGY INC.

Attention

- The content of this material is a previous notice and might change.
- The reprint reproduction of this material is prohibited without our approval by the document.
- Our company doesn't carry the for the mistake of this material at all.
- Our company doesn't carry the for the violation of the patent, the copyright of the third party generated in relation to the use of our product published in this material, and other intellectual property rights etc. at all. Our company doesn't permit our or third party's any patents, copyrights, and other intellectual property rights based on this material.
- Information that relates to the circuit, software, and these described to this material explains the operation example and the application example of the semiconductor product.

Please go to design customer's equipment in customer's responsibility when you use information on the circuit, software, and these. Our company doesn't carry the for the damage caused in the customer or the third party who originates in these use at all.

Table of contents

1. TK-850/KJ2.....	2
1.1. Features.....	2
1.2. Attached goods list.....	2
1.3. Hardware specification.....	2
1.4. Terminal list.....	3
2. Switches and LED.....	7
2.2. SW1.....	7
2.2. SW2.....	7
2.3. SW3.....	7
2.4. SW4.....	8
2.5. LED1.....	8
2.6. JP1.....	8
2.7. NWIRE1 Connector.....	9
2.8. U2 (7seg LED) ,.....	10
3. Connector Pin Termination Note.....	11
3.1. Solder-short pad label.....	11
3.2. Operation by external power supply.....	12
4. TK-850/KJ2 data.....	13
4.1. Parts arrangement plane.....	13
4.2. Solder-short pad arrangement plane.....	13
4.3. Measure plane of PWB.....	14
4.4. Circuit chart.....	15

1. TK-850/KJ2

V850ES/Kx2 is the NEC Electronics 32bit single chip microcomputer. The features and hardware specification of an evaluation board (TK-850/KJ2CPU board) of V850ES/Kx2 series are described.

1.1. Features

Features of the TK-850/KJ2 CPU board are as follows.

The evaluation board used the NEC Electronics 32bit single chip microcontroller. (μ PD70F3734GJ). All of the ROM, RAM and circumference circuit are efficiently built in one chip on a single board.

- High-speed operation is realized via the 20MHz internal clock..
- 32.768KHz sub-clock standard equipment
- The high speed RAM: 16 K-byte is built into CPU chip by the flash memory 256 K-byte.
- 128 I/O ports are equipped at the maximum.
- The board itself is quite small and easy to handle; about the size of a business card.

1.2. Attached goods list

- TK-850/KJ2 CPU board
- Development tool/Manual CD-ROM
- USB cable(MINI B \longleftrightarrow A)

1.3. Hardware specification

CPU	μ PD70F3734GJ-UEN-A
Frequency of operation	20MHz operation (sub-clock:32.768KHz)
Interface	USB (MINI B connector) Connector for N-Wire (Only solder pad) The circumference board connector 50pin socket x2 (Only solder pad)
Operation pressure	5V

1.4. Terminal list

It is TK-850/KJ2CPU board of terminal table of CN1 and CN2.

CN1, CN2 are not mounted.

CN1 terminal list(HIF-3H-50DA-2.54DSA[not mounted]by Hirose)

CN1	Signal name	Terminal CPU name at connection destination	Notes
1	AVREF0	AVREF0	Connected VDD by the pad for solder-short
2	VSS	AVSS,VSS,EVSS,BVSS	
3	P10	P10/ANO0	
4	P11	P11/ANO1	
5	AVREF1	AVREF1	Connected VDD by the pad for solder-short
6	P00	P00/TOH0	
7	P01	P01/TOH1	
8	FLMD0	FLMD0	Connect it with the FLMD0 control logic.
9	VDD	VDD	
10	+12V		It connects it with CN3 and J1.
11	VSS	AVSS,VSS,EVSS,BVSS	
12	+12V		It connects it with CN3 and J1.
13	VDD	VDD	
14	RESET0	RESET	It connects it with the reset circuit etc.
15	VDD	VDD	
16	+12V		It connects it with CN3 and J1.
17	P02	P02/NMI	
18	P03	P03/INTP0	SW2
19	P04	P04/INTP1	SW1
20	P05	P05/INTP2/DRST	
21	P06	P06/INTP3	
22	P40	P40/SI00/RXD2	
23	P41	P41/SO00/TXD2	
24	P42	P42/SCK00	
25	P30	P30/TXD0/TO02	Connected RXD by the pad for solder-short
26	P31	P31/RXD0/INTP7/TO03	Connected TXD by the pad for solder-short
27	P32	P32/ASCK0/ADTRG/TO01	

28	P33	P33/TI000/TO00/TIP00/TOP00	
29	P34	P34/TI001/TO00/TIP01/TOP01	
30	P35	P35/TI010/TO01	
31	P36	P36	
32	P37	P37	
33	VSS	AVSS,VSS,EVSS,BVSS	
34	EVDD	EVDD	Connected VDD by the pad for solder-short
35	P38	P38/SDA0	
36	P39	P39/SCL0	
37	P50	P50/TI011/RTP00/KR0	
38	P51	P51/TI50/RTP01/KR1	
39	P52	P52/TO50/RTP02/KR2/DDI	
40	P53	P53/SIA0/RTP03/KR3/DDO	
41	P54	P54/SOA0/RTP04/KR4/DCK	
42	P55	P55/SCKA0/RTP05/KR5/DMS	
43	P90	P90/A0/TXD1/KR6	
44	P91	P91/A1/RXD1/KR7	
45	P92	P92/A2/TI020/TO02	
46	P93	P93/A3/TI021	
47	P94	P94/A4/TI030/TO03	
48	P95	P95/A5/TI031	
49	P96	P96/A6/TI51/TO51	
50	P97	P97/A7/SI01	

CN2 terminal list(HIF-3H-50DA-2.54DSA[not mounted]by Hirose)

CN2	Signal name	Terminal CPU name at connection destination	Notes
1	P98	P98/A8/SO01	
2	P99	P99/A9/SCK01	
3	P910	P910/A10/SIA1	
4	P911	P911/A11/SOA1	
5	P912	P912/A12/SCKA1	
6	P913	P913/A13/INTP4	
7	P914	P914/A14/INTP5	
8	P915	P915/A15/INTP6	
9	PCS0	PCS0/CS0	
10	PCS1	PCS1/CS1	
11	PCM0	PCM0/WAIT	
12	PCM1	PCM1/CLKOUT	
13	PCM2	PCM2/HLDAK	
14	PCM3	PCM3/HLDRQ	
15	PCT0	PCT0/WR0	
16	PCT1	PCT1/WR1	
17	PCT4	PCT4/RD	
18	PCT6	PCT6/ASTB	
19	VSS	AVSS,VSS,EVSS,BVSS	
20	BVDD	BVDD	Connected VDD by the pad for solder-short
21	PDL0	PDL0/AD0	
22	PDL1	PDL1/AD1	
23	PDL2	PDL2/AD2	
24	PDL3	PDL3/AD3	
25	PDL4	PDL4/AD4	
26	PDL5	PDL5/AD5/FLMD1	10k Ω pull-down
27	PDL6	PDL6/AD6	
28	PDL7	PDL7/AD7	
29	PDL8	PDL8/AD8	
30	PDL9	PDL9/AD9	

31	PDL10	PDL10/AD10	
32	PDL11	PDL11/AD11	
33	PDL12	PDL12/AD12	
34	PDL13	PDL13/AD13	
35	PDL14	PDL14/AD14	
36	PDL15	PDL15/AD15	
37	PDH0	PDH0/A16	
38	PDH1	PDH1/A17	
39	PDH2	PDH2/A18	
40	PDH3	PDH3/A19	
41	PDH4	PDH4/A20	
42	PDH5	PDH5/A21	
43	P77	P77/ANI7	Pulled down 1M Ω by the pad for solder-short
44	P76	P76/ANI6	Pulled down 1M Ω by the pad for solder-short
45	P75	P75/ANI5	Pulled down 1M Ω by the pad for solder-short
46	P74	P74/ANI4	Pulled down 1M Ω by the pad for solder-short
47	P73	P73/ANI3	Pulled down 1M Ω by the pad for solder-short
48	P72	P72/ANI2	Pulled down 1M Ω by the pad for solder-short
49	P71	P71/ANI1	Pulled down 1M Ω by the pad for solder-short
50	P70	P70/ANI0	Pulled down 1M Ω by the pad for solder-short

2. Switches and LED

2.2. SW1

It is connected with terminal P04/INTP1 of CPU. It becomes "Low" if it pushes, it becomes "Open" if it separates, and turn ON pull-up resistor (PU0) with built-in CPU, please when using it.

2.2. SW2

It is connected with terminal P03/INTP0 of CPU. It becomes "Low" if it pushes, it becomes "Open" if it separates, and turn ON pull-up resistor (PU0) with built-in CPU, please when using it.

2.3. SW3

Mode setting of bit1-4 of SW3.Bit5-8 is Dip switch for the general-purpose input port connected with PCD0~PCD3.

2.3.1 Please change to the following settings when you use ID850-TK of this Product attachment.

SW3

Bit 1	ON
Bit 2	ON
Bit 3	ON
Bit 4	OFF

※1 When ID850-TK is used, these terminals cannot be used because it communicates with the host machine by using and the terminal P30 and P31.

2.3.2. Please change to the following settings and reset it once when you execute the program written in the flash memory with built-in CPU without using ID850-TK.

SW3

Bit 1	OFF
Bit 2	OFF
Bit 3	OFF
Bit 4	OFF

2.3.3. Please change to the following settings when writing it in the flash memory with built-in CPU by using PG-FPL. (The hardware of PG-FPL is built into TK-850.)

SW3

Bit 1	ON
Bit 2	OFF
Bit 3	ON
Bit 4	ON

2.3.4. Please change to the following settings when you connect N-wire emulator.

SW3

Bit 1	OFF
Bit 2	OFF
Bit 3	OFF
Bit 4	OFF

2.3.5. Bit5-8 of SW3 is connected with the following terminals CPU.

It connects it with GND by turning on. When you use it, please turn ON pull-up resistor (PUCD) with a built-in CPU. It becomes "Low" if the switch turning on. And it becomes "High" if the switch turning off.

SW3

Bit 5	PCD0
Bit 6	PCD1
Bit 7	PCD2
Bit 8	PCD3

2.4. SW4

SW4 is the reset switch.

CPU can be reset by pushing.

2.5. LED1

'Power LED'. LED1 is activated when the power supply is turned on.

2.6. JP1

It is power supply of CPU former specification.

Short USB connected with the USB1 connector supplies the power supply.

Open The power supply is supplied from the outside.

2.7. NWIRE1 Connector

These are connector for N-Wire emulator.

It can connect N-Wire emulator of IE-V850E1-CD-NW etc.

NWIRE1 can connect to N-Wire emulator by installing a connector.

(8830E-026-170S [not mounted] by KEL Corp.)

Also, NWIRE2 can connect to N-Wire emulator by installing a connector (SICA2P20S[not mounted] by Tokyo Eletech) and going through a conversion adapter(SICA20I2P by Tokyo Eletech).

Please do the following setting when you connect N-Wire emulator.

- Bit1,2, 3, 4, of SW3 are turned off.

2.8. U2 (7seg LED) ,

7seg LED of U2 can be lit with P60-P67.

Please set the port mode to the output, and output “Low” signal from the port.

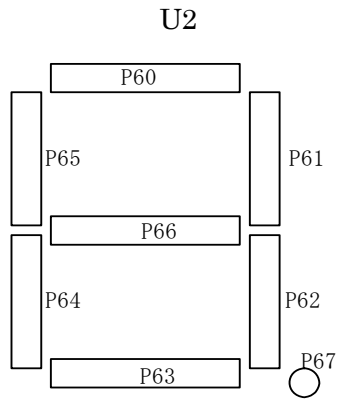

The figure of 0-9 can be displayed by writing the following values in P6 register.

Example of displayed figure and set data

0	0xC0	5	0x92
1	0xF9	6	0x83
2	0xA4	7	0xf8
3	0xB0	8	0x80
4	0x99	9	0x98

3. Connector Pin Termination Note

3.1. Solder-short pad label

The terminal of CPU can be customized by opening the pad for short solder to separate the circuit of onboard when the circuit of onboard is not used and connector (CN1,CN2) of the board in the surrounding is used.

Pad for solder-short has shape like the figure below.

Please absorb solder with a soldering iron etc. when opening.

Solder-short pad (opened shape)



Solder-short pad name	State when shipping it	Connection
P70~P77	Short	Pull-down resistance of 1MΩ ----- Open when using it as terminal A/D
RXD, TXD	Short	Terminal RXD, TXD, P30, and P31 of FT232 ----- Open when using it by other usages without using ID850-TK
TXD-T	Open	TXD ----- Short when you want to carry out baud rate measurement using P612/TI050 terminal.
FLMD0	Open	Terminal FLMD0 of CPU ----- Short when rewrite the built-in flash memory by self which uses P80 connector.
REGC	Short	VDD ----- Open when connecting a capacitor to a REGC terminal and using a regulator with a built-in CPU.
AVREF0, AVREF1	Short	VDD ----- Open when AVREF0 and AVREF1 are driven by other voltages
BVDD	Short	VDD ----- Open when BVDD is driven by other voltages
EVDD	Short	VDD ----- Open when EVDD is driven by other voltages
DCVDD1, DCVDD2	Open	AC adaptor power supply and J1 of CN3 ----- When assuming VDD, it is Short as for the power supply of CN3 J1

3.2. Operation by external power supply

The power supply of the AC adaptor connected with CN3 is connected only with the power supply terminal of the connector of the board in the surrounding (10, 12, and 16pin of CN1). However, not to tie to USB this board and to operate with the unit, the AC adaptor can be made a power supply by the connection of the AC adaptor of 5V to CN3 and the short-circuit of solder short pad (DCVDD1,2).

Moreover, it is also possible to connect the stabilizing supply etc. in the lead line instead of the AC adaptor because CN3 is connected with J1 of a through hole.

- Acceptable jack (CN3) : HEC0470-01-630 by Hosiden Corp(not mounted)
- Acceptable plug : 2.1mm DC jack(center plus)
- Current capacity : 100mA or more

- J1-1pin : plus
- J1-2pin : minus

Attention : Please make JP1 Open when operating in an external power supply

4. TK-850/KJ2 data

4.1. Parts arrangement plane

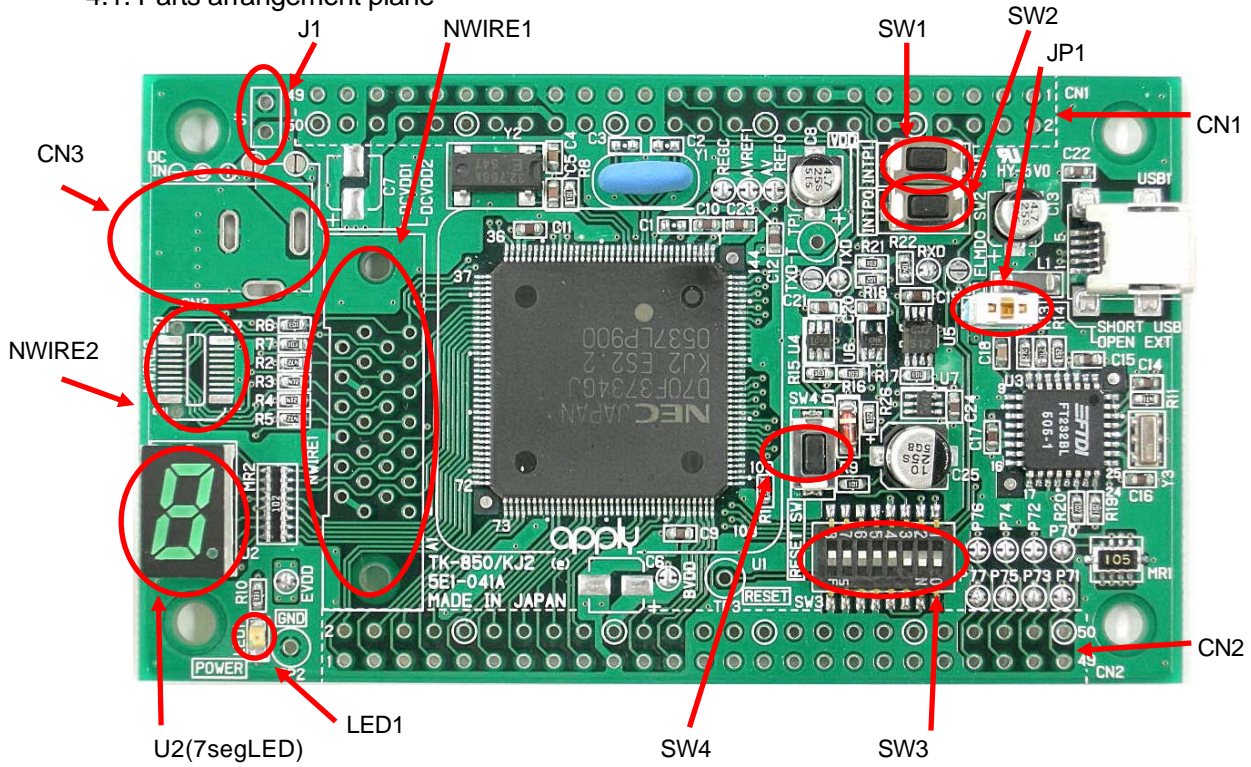

4.2. Solder-short pad arrangement plane

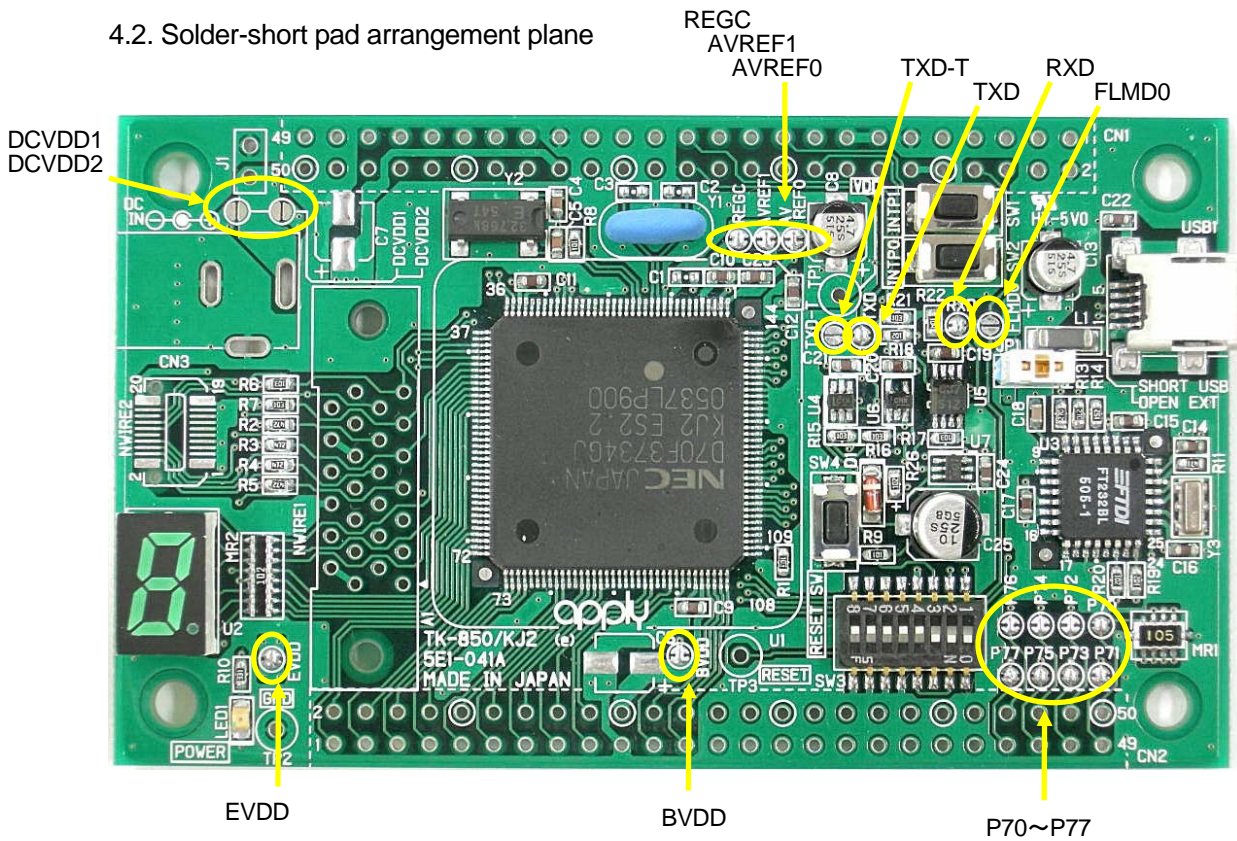

4.3. Measure plane of PWB

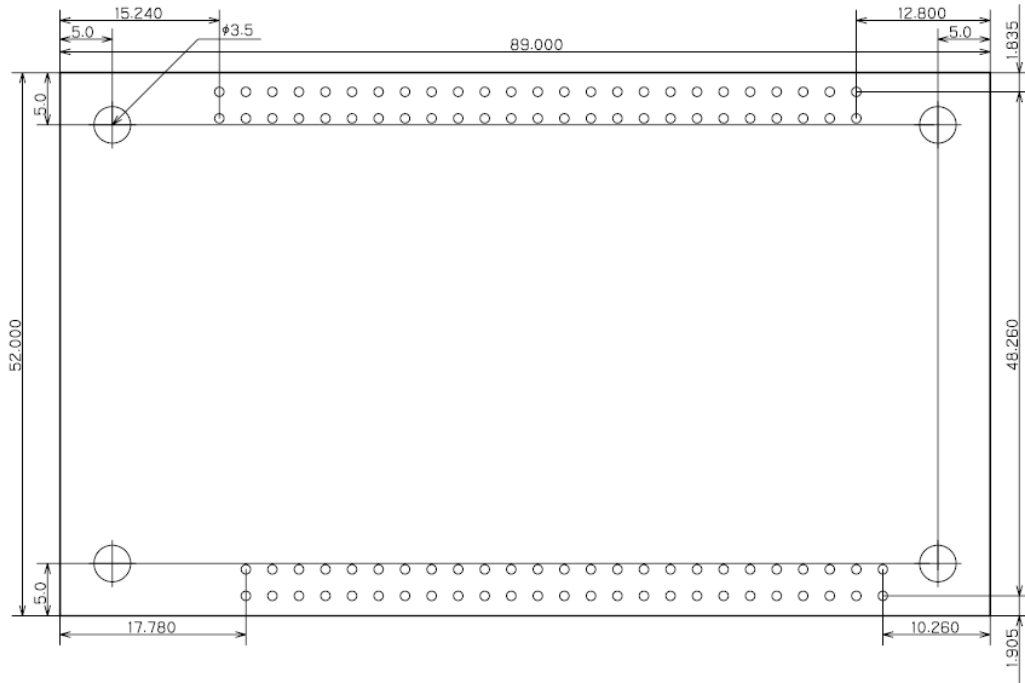

4.4. Circuit chart

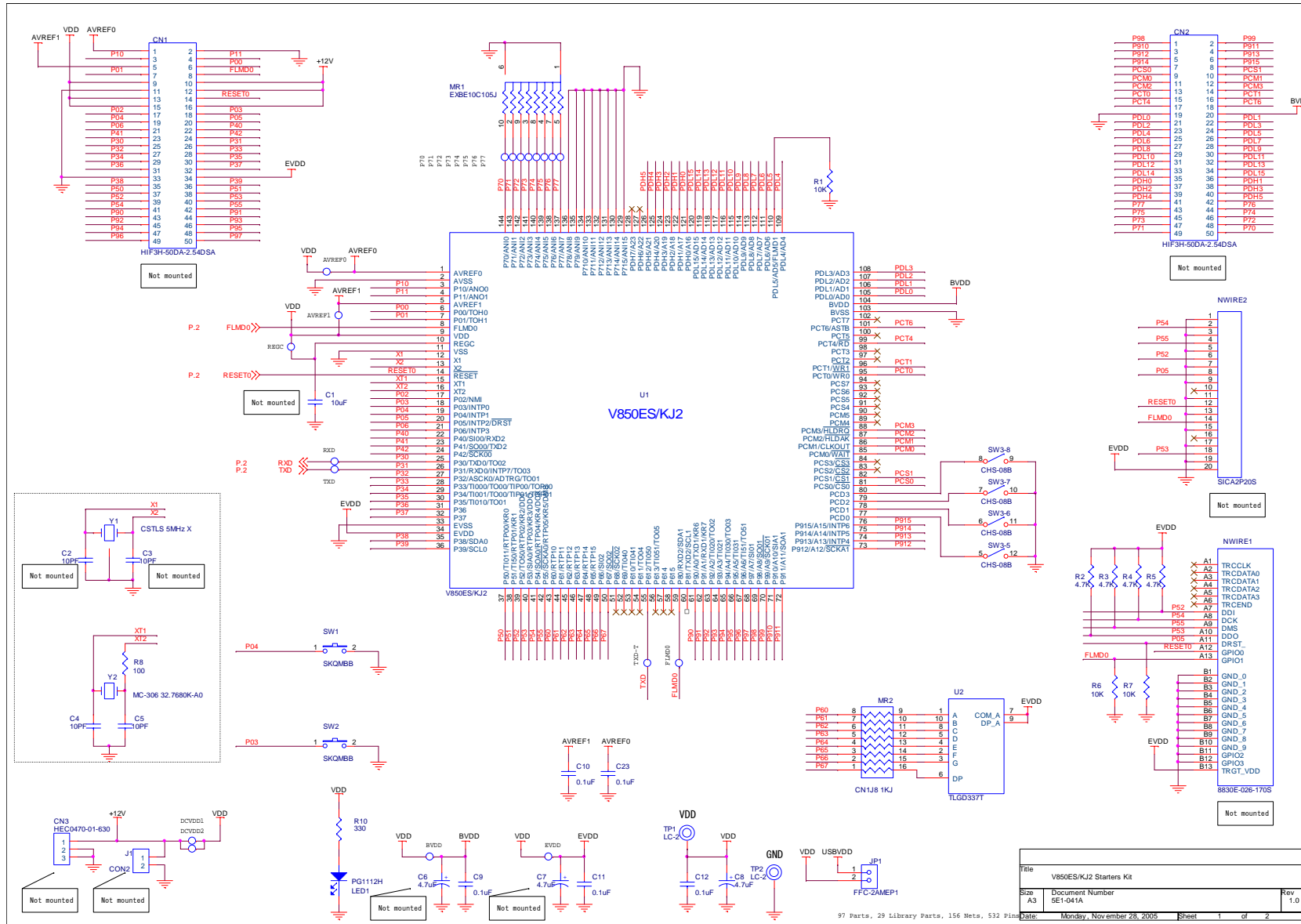

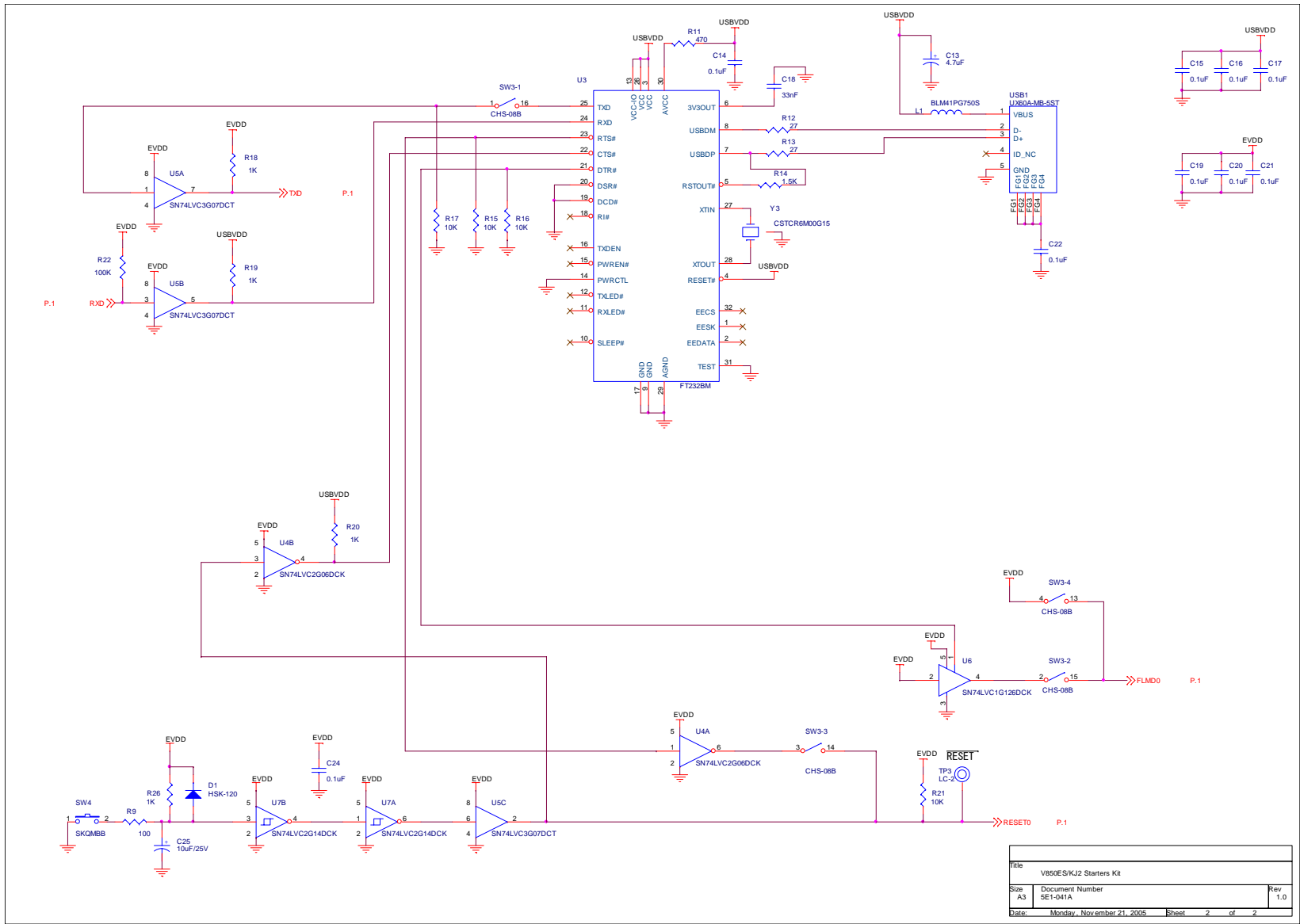

File: V850ESKJ2 Starters Kit		
Size: A3	Document Number: SE1-041A	Rev: 1.0
Date: Monday, November 21, 2005	Sheet: 2	of 2